



Low voltage

# EasyPact SPS

LV power circuit breakers and switch-disconnectors  
800 to 1600A

Catalogue  
2013



**Schneider**  
Electric





---

Functions  
and characteristics

A-1



---

Installation  
recommendations

B-1



---

Dimensions  
and connection

C-1



---

Electrical diagrams

D-1



---

Additional  
characteristics

E-1



---

Catalogue numbers  
and order form

F-1



# Functions and characteristics



<b>General overview</b>	<b>A-2</b>
Detailed contents	A-2
<b>Circuit breakers and switch-disconnectors</b>	<b>A-4</b>
SPS08 to SPS16	A-4
<b>Identifying ET range of trip system</b>	<b>A-6</b>
<b>Overview of functions</b>	<b>A-7</b>
ET trip system	A-7
<b>ET range of trip system</b>	<b>A-9</b>
Accessories and test equipment	A-9
<b>Connections</b>	<b>A-10</b>
Overview of solutions and accessories	A-10
Accessories and auxiliaries	A-11
<b>Locking</b>	<b>A-13</b>
On the device	A-13
On the chassis	A-14
<b>Indication contacts</b>	<b>A-15</b>
<b>Remote operation</b>	<b>A-16</b>
Remote ON / OFF	A-16
Remote tripping	A-18
<b>Source-changeover systems</b>	<b>A-19</b>
Mechanical interlocking	A-19
<b>Accessories</b>	<b>A-20</b>
<i>Installation recommendations</i>	<i>B-1</i>
<i>Dimensions and connection</i>	<i>C-1</i>
<i>Electrical diagrams</i>	<i>D-1</i>
<i>Additional characteristics</i>	<i>E-1</i>
<i>Catalogue numbers and order form</i>	<i>F-1</i>

This overview describes all the functions offered by EasyPact SPS devices.



ET2.0 trip system.



ET6G trip system.

**Circuit breakers and switch-disconnectors** page A-4

- Ratings:
  - EasyPact SPS 800 to 1600 A
- Circuit breakers type F
- Switch-disconnectors type FA
- 3 or 4 poles
- Fixed or drawout versions

**ET trip system** page A-6

- 2.0 basic protection
- 6G selective + earth-fault protection
- Standard long-time rating plug:
  - Current setting (A) 0.4 to 1 x I<sub>n</sub>

**Connections** page A-10

- Rear connection:
  - Vertical
- Optional accessories:
  - Interphase barriers
  - Spreaders

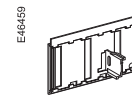

Safety shutters

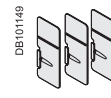

Interphase barriers

**Locking** page A-13

- Pushbutton locking by padlockable transparent cover
- OFF-position locking by keylock
- Chassis locking in disconnected position by keylock
- Door interlock (inhibits door opening with breaker in 'connected' or 'test' position)

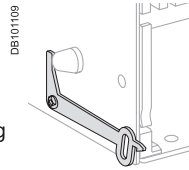

Door interlock

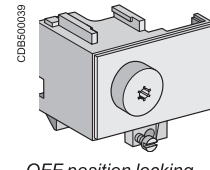

OFF position locking



PB104354440

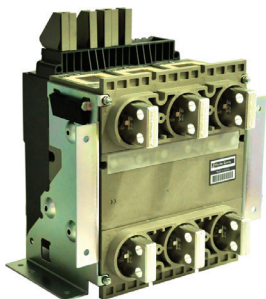

### Indication contacts

page A-15

- Standard:
  - ON/OFF indication (OF)
  - "Fault" trip indication (SDE)
- Optional:
  - Additional ON/OFF indication (OF)
  - Ready-to-close contact (PF)
  - Carriage switches for connected (CE) disconnected (CD) and test (CT) positions

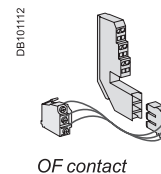
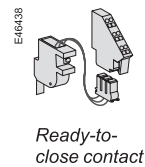

CPB100003



### Remote operation

page A-16

- Remote ON/OFF:
  - Gear motor
  - XF closing or MX opening voltage releases
- Remote tripping function:
  - MN voltage release
  - Standard
  - Adjustable or non-adjustable delay

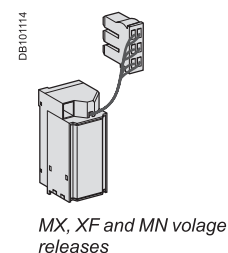
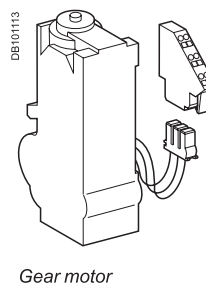

CPB100016

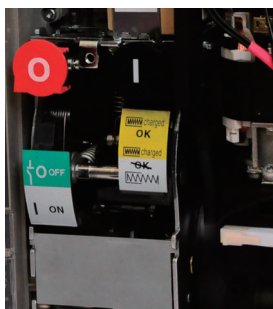

CPB100016

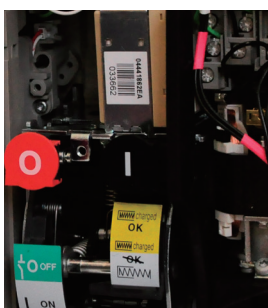

### Source-changeover systems

page A-19

- Mechanical interlocking using cables:
  - Interlocking between two devices

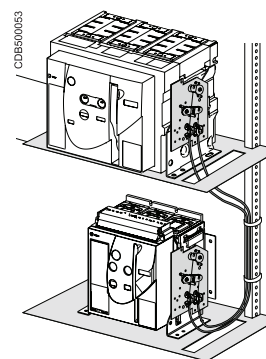

### Accessories

page A-20

- Auxiliary terminal shield
- Escutcheon (Door sealing frame)
- Transparent cover for escutcheon
- Escutcheon blanking plate

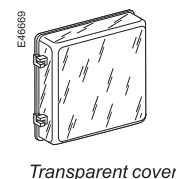
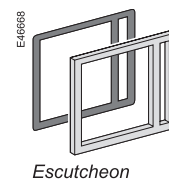

# Circuit breakers and switch-disconnectors

## SPS08 to SPS16

CPB100014



Circuit breaker.

CPB100000



Switch-disconnector.

### Common characteristics

Number of poles		3/4
Rated insulation voltage (V)	Ui	1000
Impulse withstand voltage (kV)	Uimp	12
Rated operational voltage (V AC 50/60 Hz)	Ue	440
Suitability for isolation	IEC 60947-2	Yes
Degree of pollution	IEC 60664-1	3

### Basic circuit-breaker

#### Circuit-breaker as per IEC 60947-2

Rated current (A)	In	at 40°C <sup>(1)</sup>
Rating of 4th pole (A)		
Sensor ratings (A)		

#### Type of circuit breaker

Ultimate breaking capacity (kA rms) V AC 50/60 Hz	Icu	220...440V
Rated service breaking capacity (kA rms)	Ics	% Icu
Utilisation category		
Rated short-time withstand current (kA rms) V AC 50/60 Hz	Icw	1s

Rated making capacity (kA peak) V AC 50/60 Hz	Icm	220...440 V
Breaking time (ms) between tripping order and arc extinction		
Closing time (ms)		

### Switch-disconnector as per IEC60947-3 and Annex A

#### Type of switch-disconnector

Operational current AC23A		
Rated making capacity (kA peak)	Icm	
Rated short-time withstand current (kA rms)	Icw	1s

### Maintenance/Connection/Installation

Service life	Mechanical	without maintenance	
C/O cyclesx1000	Electrical	without maintenance	440 V
Connection		Horizontal	
		Vertical	
Dimensions (mm) (H x W x D)	Drawout		3P
			4P
	Fixed		3P
			4P
Weight (kg) (approximate)	Drawout		3P/4P
	Fixed		3P/4P

<sup>(1)</sup> Refer page no. B-11 for details on temperature derating.





	SPS08	SPS10	SPS12	SPS16
	800	1000	1250	1600
	800	1000	1250	1600
	800	1000	1250	1600
	<b>F</b>	<b>F</b>	<b>F</b>	<b>F</b>
	50	50	50	50
	100%	100%	100%	100%
	B	B	B	B
	42	42	42	42
	105	105	105	105
	25	25	25	25
	<50	<50	<50	<50

	SPS08	SPS10	SPS12	SPS16
	<b>FA</b>	<b>FA</b>	<b>FA</b>	<b>FA</b>
	800	1000	1250	1600
	75	75	75	75
	36	36	36	36

	12.5	12.5	12.5	12.5
	6	6	6	6
	No			
	Yes			
	322 x 288x 277			
	322 x 358x 277			
	301 x 276 x 196			
	301 x 346 x 196			
	30/39			
	14/18			

# Identifying ET range of trip system

EasyPact SPS circuit breakers equipped with ET range of trip system are designed to protect power circuit and connected loads.

CPB100011



## Dependability

Integration of protection functions in an ASIC electronic component used in all trip units guarantees a high degree of reliability and immunity to conducted or radiated disturbances.

On ET range, protection functions ensure system protection even at very low load currents.

## Accessories

Certain functions require the addition of trip unit accessories, described on page A-9.

### Trip unit name codes

#### Type of protection

- 2.0 for basic protection
- 6G for selective + earth-fault protection

### ET2.0: basic protection

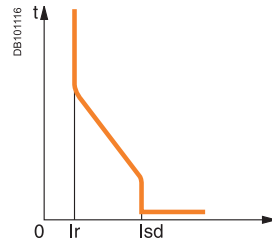

**Protection:**  
long time  
+ instantaneous

### ET6G: selective + earth-fault protection

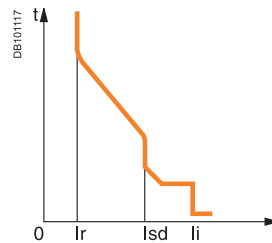

**Protection:**  
long time  
+ short time  
+ instantaneous  
+ earth fault

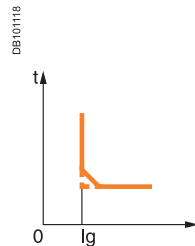

ET trip unit protect power circuits, under overload & short-circuit conditions. ET6G provides earth-fault protection and equipped with individual fault trip indication LEDs.

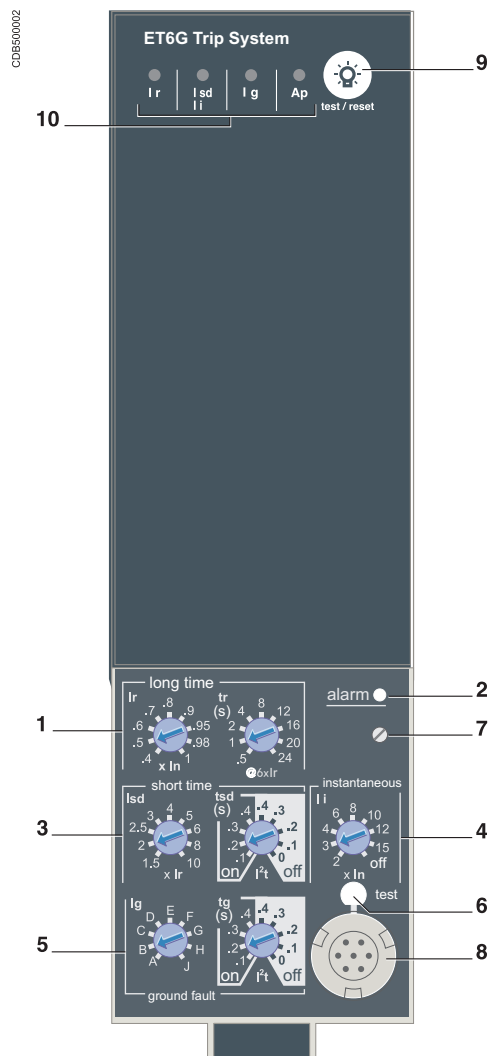

- 1 Long-time threshold and tripping delay.
- 2 Overload alarm (LED) at 1, 125 I<sub>r</sub>.
- 3 Short-time pick-up and tripping delay.
- 4 Instantaneous pick-up.
- 5 Earth-fault pick-up and tripping delay.
- 6 Earth-fault test button.
- 7 Long-time rating plug screw.
- 8 Test connector.
- 9 Lamp test, reset and battery test.
- 10 Indication of tripping cause.

(1) The thermal memory continuously accounts for the amount of heat in the cables, both before and after tripping, whatever the value of the current (presence of an overload or not). The thermal memory optimises the long-time protection function of the circuit breaker by taking into account the temperature rise in the cables. The thermal memory assumes a cable cooling time of approximately 20 minutes.

(2) Applicable on ET6G trip system

**Note:** ET trip control units come with a transparent leadseal cover as standard.

## Protection

Protection thresholds and delays are set using the adjustment dials.

### Overload protection

True rms long-time protection.  
Protects cables (phase and neutral) against overloads  
Thermal memory<sup>(1)</sup>: thermal image before and after tripping.

### Short-time protection

- The short-time protection function protects the distribution system against impeded short-circuits
- The short-time tripping delay can be used to ensure discrimination with downstream circuit breaker (on ET6G)
- The I<sup>2</sup>t ON and I<sup>2</sup>t OFF options enhance discrimination with a downstream protection devices (on ET6G)
- Use of I<sup>2</sup>t curves with short-time protection:
  - I<sup>2</sup>t OFF selected: the protection function implements a constant time curve
  - I<sup>2</sup>t ON selected: the protection function implements an I<sup>2</sup>t inverse-time curve up to 10 I<sub>r</sub>. Above 10 I<sub>r</sub>, the time curve is constant

### Earth-fault protection on ET6G trip system

Residual earth fault protection.

Selection of I<sup>2</sup>t type (ON or OFF) for delay.

A ground fault in the protection conductors can provoke local temperature rise at the site of the fault or in the conductors. The purpose of the ground-fault protection function is to eliminate this type of fault.

Type	Description
Residual	<ul style="list-style-type: none"> <li>■ The function determines the zero-phase sequence current, i.e. the vectorial sum of the phase and neutral currents</li> <li>■ It detects faults downstream of the circuit breaker</li> </ul>

### Instantaneous protection

The Instantaneous-protection function protects the distribution system against solid short-circuits. Contrary to the short-time protection function, the tripping delay for instantaneous protection is not adjustable. The tripping order is sent to the circuit breaker as soon as current exceeds the set value, with a fixed time delay of 20 milliseconds.

### Neutral protection

On three-pole circuit breakers, neutral protection is not possible.

On four-pole circuit breakers, neutral protection may be set using a three-position switch: neutral unprotected (4P 3d), neutral protection at 0.5 I<sub>r</sub> (4P 3d + N/2), neutral protection at I<sub>r</sub> (4P 4d).

### Overload alarm

A yellow alarm LED goes on when the current exceeds the long-time trip threshold.

### Fault indications<sup>(2)</sup>

LEDs indicate the type of fault:

- Overload (long-time protection I<sub>r</sub>)
- Short-circuit (short-time I<sub>sd</sub> or instantaneous I<sub>i</sub> protection)
- Earth fault (I<sub>g</sub>)
- Internal fault (Ap)

### Battery power

The fault indicating LEDs are powered by an in-built battery. The fault indication LEDs remain on until the test/reset button is pressed.

### Test

A hand-held test kit may be connected to the test connector on the front to check circuit-breaker operation. For ET6G trip unit, the operation of earth-fault protection can be checked by pressing the test button located above the test connector.



**Protection ET2.0**

Long time		ET2.0									
Current setting (A)	$I_r = I_n \times \dots$	0.4	0.5	0.6	0.7	0.8	0.9	0.95	0.98	1	
Tripping between 1.05 and 1.20 x $I_r$											
Time setting		<b>tr (s)</b>	0.5	1	2	4	8	12	16	20	24
Time delay (s)	Accuracy: 0 to -30 %	$1.5 \times I_r$	12.5	25	50	100	200	300	400	500	600
	Accuracy: 0 to -20 %	$6 \times I_r$	0.7 <sup>(1)</sup>	1	2	4	8	12	16	20	24
	Accuracy: 0 to -20 %	$7.2 \times I_r$	0.7 <sup>(2)</sup>	0.69	1.38	2.7	5.5	8.3	11	13.8	16.6
Thermal memory			20 minutes before and after tripping								
<i>(1) 0 to -40 % - (2) 0 to -60 %</i>											
Instantaneous											
Pick-up (A)	$I_{sd} = I_r \times \dots$	1.5	2	2.5	3	4	5	6	8	10	
Accuracy: ±10 %											
Time delay		Max resettable time: 20 ms Max break time: 80 ms									

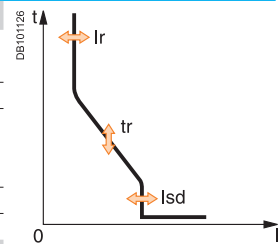

**Protection ET 6G**

Long time		ET6G									
Current setting (A)	$I_r = I_n \times \dots$	0.4	0.5	0.6	0.7	0.8	0.9	0.95	0.98	1	
Tripping between 1.05 and 1.20 x $I_r$											
Time setting		<b>tr (s)</b>	0.5	1	2	4	8	12	16	20	24
Time delay (s)	Accuracy: 0 to -30 %	$1.5 \times I_r$	12.5	25	50	100	200	300	400	500	600
	Accuracy: 0 to -20 %	$6 \times I_r$	0.7 <sup>(1)</sup>	1	2	4	8	12	16	20	24
	Accuracy: 0 to -20 %	$7.2 \times I_r$	0.7 <sup>(2)</sup>	0.69	1.38	2.7	5.5	8.3	11	13.8	16.6
Thermal memory			20 minutes before and after tripping								
<i>(1) 0 to -40 % - (2) 0 to -60 %</i>											
Short time											
Pick-up (A)	$I_{sd} = I_r \times \dots$	1.5	2	2.5	3	4	5	6	8	10	
Accuracy: ±10 %											
Time setting tsd (s)	Settings	$I^2t$ Off	0	0.1	0.2	0.3	0.4				
		$I^2t$ On	-	0.1	0.2	0.3	0.4				
Time delay (ms) at 10 x $I_r$ ( $I^2t$ Off or $I^2t$ On)		tsd (max resettable time)	20	80	140	230	350				
		tsd (max break time)	80	140	200	320	500				
Instantaneous											
Pick-up (A)	$I_i = I_n \times \dots$	2	3	4	6	8	10	12	15	off	
Accuracy: ±10 %											
Time delay		Max resettable time: 20 ms Max break time: 50 ms									
Earth fault		ET6G									
Pick-up (A)	$I_g = I_n \times \dots$	A	B	C	D	E	F	G	H	J	
Accuracy: ±10 %	$I_n \leq 400$ A	0.3	0.3	0.4	0.5	0.6	0.7	0.8	0.9	1	
	$400$ A < $I_n \leq 1000$ A	0.2	0.3	0.4	0.5	0.6	0.7	0.8	0.9	1	
	$I_n \geq 1250$ A	500	640	720	800	880	960	1040	1120	1200	
Time setting tg (s)	Settings	$I^2t$ Off	0	0.1	0.2	0.3	0.4				
		$I^2t$ On	-	0.1	0.2	0.3	0.4				
Time delay (ms)		tg (max resettable time)	20	80	140	230	350				
		tg (max break time)	80	140	200	320	500				

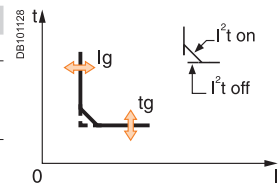
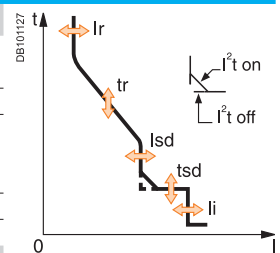

**Note:** All current-based protection functions require no auxiliary source. The test / reset button, clears the tripping indication and tests the battery.



DB101524

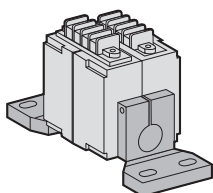

External sensor (CT).

PB100775-32



Lead-seal cover.

CD5600036

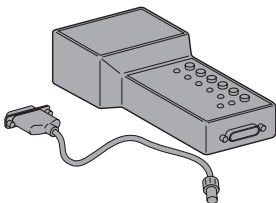

Hand-held test kit.

### External sensors

#### External sensor for earth-fault protection

The sensors, used with the 3P circuit breakers, are installed on the neutral conductor for:

- Residual type earth-fault protection (with ET6G trip units)
- The rating of the sensor (CT) must be compatible with the rating of the circuit breaker:
- SPS08 to SPS16: TC 400/1600

### Spare parts

#### Lead-seal covers

A lead-seal cover controls access to the adjustment dials.

When the cover is closed:

- It is impossible to modify settings using the keypad unless the settings lockout pin on the cover is removed
- The test connector remains accessible
- The test button for the earth-fault protection function remains accessible

#### Characteristics

- Transparent cover for all trip units

#### Spare battery (for ET6G)

A battery supplies power to the LEDs identifying the tripping causes. The healthiness of the battery to be checked periodically. A test button on the front of the control unit is used to check the battery condition. The battery may be replaced on site when discharged.

### Test equipment

#### Hand-held test kit

The hand-held mini test kit may be used to:

- Check operation of the control unit and the tripping and pole-opening system by sending a signal simulating a short-circuit
- Power source: standard LR6-AA battery

Types of connection are available:

- Vertical rear connection

The solutions presented are similar in principle for all EasyPact SPS fixed and drawout devices.

### Rear connection

Vertical(800 & 1000A)

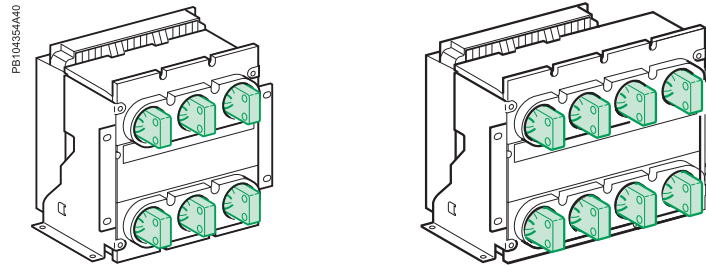

Vertical with spreaders (1250 & 1600A)

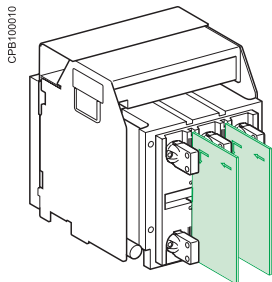
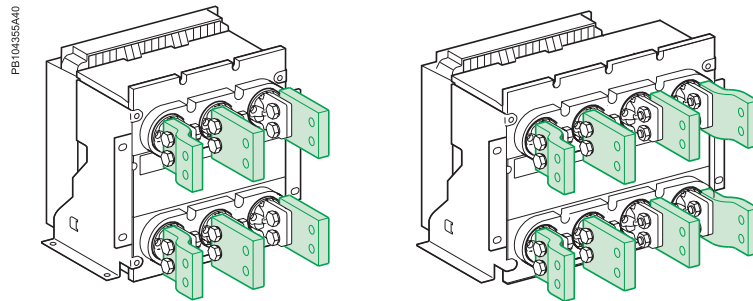

### Interphase barriers EIP(option)

These barriers are flexible insulated partitions used to reinforce isolation of connection points in installations with busbars, whether insulated or not. For EasyPact SPS devices, they are installed vertically between rear connection terminals.

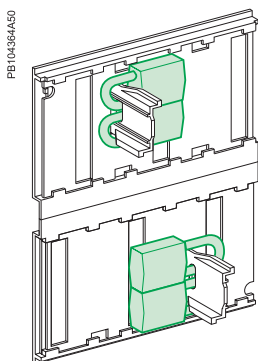







### Safety shutters VO(standard)

Mounted on the chassis, the safety shutters automatically block access to the disconnecting contact cluster when the device is in the disconnected or test positions (degree of protection IP 20) When the device is removed from its chassis, no live parts are accessible.

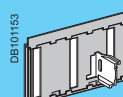

The shutter-locking system is made up of a moving block that can be padlocked (padlock not supplied). The block:

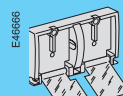
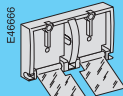
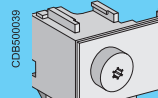
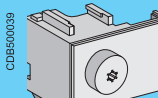
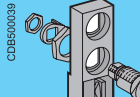
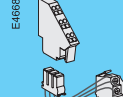
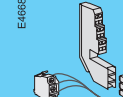
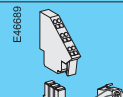
- Prevents connection of the device
- Locks the shutters in the closed position

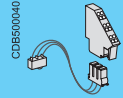
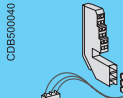
**Note:** EasyPact SPS circuit breakers can be connected indifferently with bare-copper, tinned-copper and tinned-aluminium conductors, requiring no particular treatment.

Type of accessory	EasyPact SPS08 to SPS16	
	Fixed breaker Rear connection	Drawout breaker Rear connection
Interphase barriers	 <p>DB101149</p> <p>Optional</p>	 <p>DB101149</p> <p>Optional</p>
Safety shutters		 <p>DB101153</p> <p>Standard</p>
Door interlock		 <p>DB119354</p> <p>Optional</p>
Pushbutton locking device	 <p>E46666</p> <p>Optional</p>	 <p>E46666</p> <p>Optional</p>
OFF position locking	 <p>CD8500039</p> <p>Optional</p>	 <p>CD8500039</p> <p>Optional</p>
"Disconnected" position locking		 <p>CD8500039</p> <p>Optional</p>
ON/OFF indication contacts(OF)	 <p>E46689</p> <p>2OF Standard</p>	 <p>E46689</p> <p>2OF Standard</p>
Additional ON/OFF indication contacts(OF)	 <p>E46689</p> <p>1/2OF Optional</p>	 <p>E46689</p> <p>1/2OF Optional</p>
"Fault trip" indication contact(SDE)	 <p>CD8500040</p> <p>Standard</p>	 <p>CD8500040</p> <p>Standard</p>

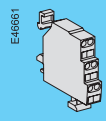
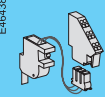
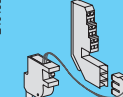
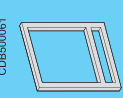
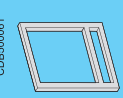
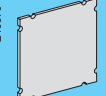

Type of accessory	EasyPact SPS08 to SPS16	
	Fixed breaker Rear connection	Drawout breaker Rear connection
"Connected, disconnected, test position" indication contact(CE,CD,CT)		 E46661 Optional
"Ready to close" contact(PF)	 E46438 Optional	 E46438 Optional
Escutcheon(CDP)	 CD9500061 Standard	 CD9500061 Standard
Escutcheon blanking plate		 E46670 Optional
Auxiliary terminal shield(CB)		 E46458 Optional
Transparent cover (IP54)		 E46669 Optional





- 1 Reset button for mechanical trip indication.
- 2 OFF pushbutton.
- 3 OFF position lock.
- 4 ON pushbutton.
- 5 Contact position indication.
- 6 Spring charge indication.

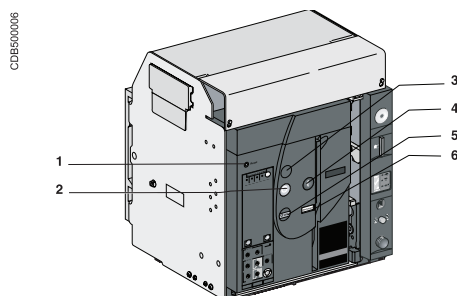

Access to pushbuttons protected by transparent cover.

### Pushbutton locking VBP

The transparent cover blocks access to the pushbuttons used to open and close the device.

It is possible to independently lock the opening button and the closing button. The locking device is often combined with a remote operating mechanism.

The pushbuttons may be locked using either:

- Three padlocks (not supplied)
- Lead seal
- Two screws



Pushbutton locking using a padlock.

### Device locking in the OFF position by keylocks VSPO

The circuit breaker is locked in the OFF position by physically maintaining the opening pushbutton pressed down:

- Using keylocks (one or two keylocks, optional)

Keys may be removed only when locking is effective (Profalux or Ronis type locks).

The keylocks are available in any of the following configurations:

- One keylock
- One keylock mounted on the device + one identical keylock supplied separately for interlocking with another device

A locking kit (without locks) is available for installation of one or two keylocks (Ronis, Profalux).

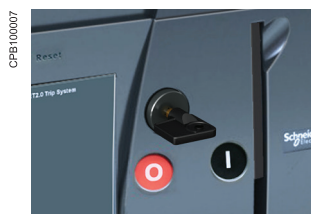

OFF position locking using a keylock.

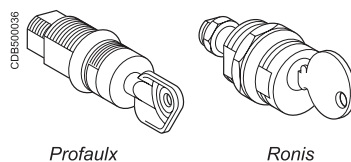

Profalux

Ronis

CB650007

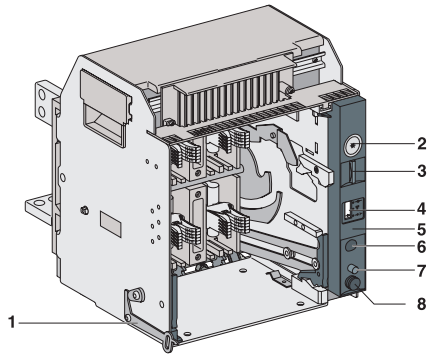

- 1 Door interlock.
- 2 Keylock locking.
- 3 Padlock locking.
- 4 Position indicator.
- 5 Chassis front plate (accessible with cubicle door closed).
- 6 Racking-handle entry.
- 7 Reset Button.
- 8 Racking-handle storage.

CPB100006



"Disconnected" position locking by padlock.

CPB100017



"Disconnected" position locking by keylock.

PB104352A32.eps



### "Connected", "disconnected" and "test" position racking interlock

The "connected", "disconnected" and "test" positions are shown by an indicator and are mechanically indexed. The exact position is obtained when the racking handle blocks. A release button is used to free it.

### "Disconnected" position locking by padlocks or keylocks VSPD

Mounted on the chassis and accessible with the door closed, these devices lock the circuit breaker in the "disconnected" position in two manners:

- Using padlocks (standard), up to three padlocks (not supplied)
- Using keylocks (optional), one or two different keylocks are available  
Profalux and Ronis keylocks are available in different options:
- One keylock
- Two identical key locks - one keylock mounted on the device + one identical keylock supplied separately for interlocking with another device

A locking kit (without locks) is available for installation of one or two keylocks (Ronis, Profalux).

#### Padlock

1. Circuit breaker in "disconnected" position.

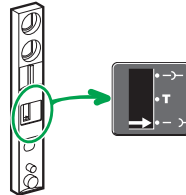

3. Insert the shackle (max. diameter 5 to 8 mm) of the padlock(s).



2. Pull out the tab.

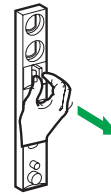

4. The crank cannot be inserted.

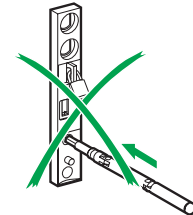

#### Keylock

1. Circuit breaker in "disconnected" position.

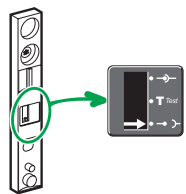

3. Remove the key(s)

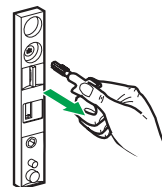

2. Turn the key(s).



4. The crank cannot be inserted.

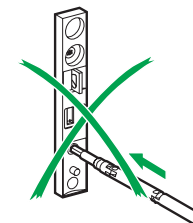

#### Door interlock catch VPEC

Mounted on the right or left-hand side of the chassis, this device inhibits opening of the cubicle door when the circuit breaker is in "connected" or "test" position. If the breaker is put in the "connected" position with the door open, the door may be closed without having to disconnect the circuit breaker.

Indication contacts are available:  
 ■ in the standard version for relay applications

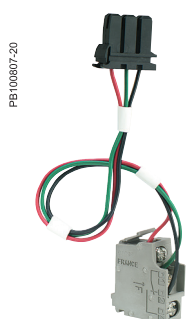

ON/OFF indication contacts (OF) (micro switch type).

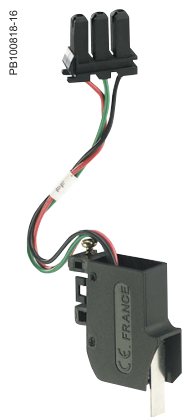

"Fault-trip" indication contact (SDE).

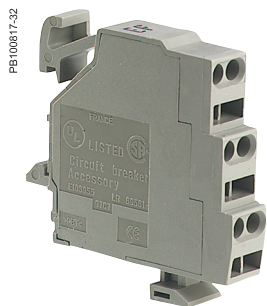

CE, CD and CT "connected/disconnected/test" position carriage switches.

## ON/OFF indication contacts OF

Indication contacts indicate the ON or OFF position of the circuit breaker:

- Rotary type changeover contacts directly driven by the mechanism for EasyPact SPS. These contacts trip when the minimum isolation distance between the main circuit-breaker contacts is reached

OF		SPS	
Supplied as standard		2C/O	
Optional contact		1C/O or 2C/O	
Breaking capacity (A)	Standard	Minimum load: 100 mA/24 V	
p.f.: 0.3		V AC	240/380 6
AC12/DC12			480 6
		V DC	24/48 2.5
			125 0.5
			250 0.3

## "Fault-trip" indication contact SDE

Circuit-breaker tripping due to a fault is signalled by:

- A red mechanical fault indicator (reset)
- One changeover contact SDE

Following tripping, the mechanical indicator must be reset before the circuit breaker may be closed. One SDE is supplied as standard.

SDE		SPS	
Supplied as standard		1	
Breaking capacity (A)	Standard	Minimum load: 100 mA/24 V	
p.f.: 0.3		V AC	240/380 5
AC12/DC12			480 5
		V DC	24/48 3
			125 0.3
			250 0.15

## "Connected", "disconnected" and "test" position carriage switches CE, CD & CT

Three series of optional auxiliary contacts are available for the chassis:

- Changeover contacts to indicate the "connected" position CE
- Changeover contacts to indicate the "disconnected" position CD. This position is indicated when the required clearance for isolation of the power and auxiliary circuits is reached
- Changeover contacts to indicate the "test" position CT. In this position, the power circuits are disconnected and the auxiliary circuits are connected

## Additional actuators

A set of additional actuators may be installed on the chassis to change the functions of the carriage switches.

Contacts		SPS	
		CE/CD/CT	
Maximum number	Standard	1 1 1	
Breaking capacity (A)	Standard	Minimum load: 100 mA/24 V	
p.f.: 0.3		V AC	240 8
AC12/DC12			380 8
			480 8
		V DC	24/48 2.5
			125 0.8
			250 0.3

A point-to-point solution for remote operation of EasyPact SPS

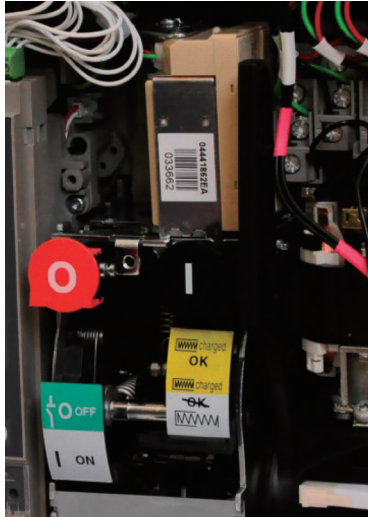

**Note:** An opening order always takes priority over a closing order.  
 If opening and closing orders occur simultaneously, the mechanism discharges without any movement of the main contacts. The circuit breaker remains in the open position (OFF).  
 In the event of maintained opening and closing orders, the standard mechanism provides an anti-pumping function by blocking the main contacts in open position.  
 Anti-pumping function. After fault tripping or intentional opening using the manual or electrical controls, the closing order must first be discontinued, then reactivated to close the circuit breaker.

The remote ON / OFF function is used to remotely open and close the circuit breaker. It is made up of:

- An electric motor MCH equipped with a "springs charged" limit switch contact CH
- Two voltage releases:
  - A closing release XF
  - An opening release MX

Optionally, other function may be added:  
 ■ A "ready to close" contact PF

A remote-operation function is generally combined with:

- Device ON / OFF indication OF
- "Fault-trip" indication SDE

Wiring diagram of a point-to-point remote ON / OFF function

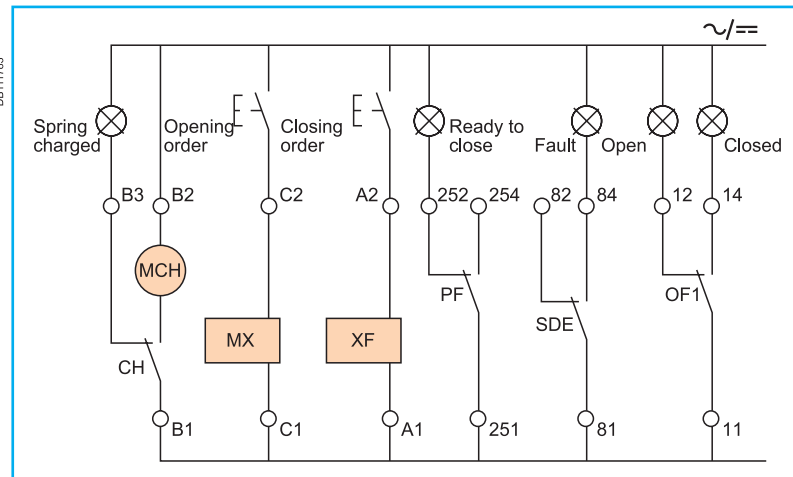

PB100808-32  
PB100797-23.eps



Electric motor MCH for EasyPact SPS.

### Electric motor MCH

The electric motor automatically charges and recharges the spring mechanism when the circuit breaker is closed. Instantaneous reclosing of the breaker is thus possible following opening. The spring-mechanism charging handle is used only as a backup if auxiliary power is absent.

The electric motor MCH is equipped as standard with a limit switch contact CH that signals the "charged" position of the mechanism (springs charged).

#### Characteristics

Power supply	V AC 50/60 Hz	48 -100/130 - 200/240 - 277/415 - 440/480 + Resistor
	V DC	24/30 - 48/60 - 100/125 - 200/250
Operating threshold	0.85 to 1.1 Un	
Consumption (VA or W)	180	
Motor overcurrent	2 to 3 In for 0.1 s	
Charging time	Maximum 3s	
Operating frequency	Maximum 3 cycles per minute	
CH contact	10 A at 240 V	

DB117037

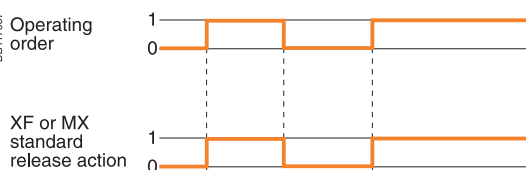

### Voltage releases XF and MX

Their supply can be maintained or automatically disconnected.

#### Closing release XF

The XF release remotely closes the circuit breaker if the spring mechanism is charged.

#### Opening release MX

The MX release instantaneously opens the circuit breaker when energised. It locks the circuit breaker in OFF position if the order is maintained.

#### Characteristics

	XF	MX
Power supply	V AC 50/60 Hz	24 - 48 - 100/130 - 200/250 - 380/480
	V DC	24/30 - 48/60 - 100/130 - 200/250
Operating threshold	0.85 to 1.1 Un	
Consumption (VA or W)	Hold: 4.5	Hold: 4.5
	Pick-up: 200 (200 ms)	Pick-up: 200 (200 ms)
Circuit-breaker response time at Un	55 ms ±10	50 ms ±10

PB100809-16



MX voltage releases.



XF voltage release.

PB100818-16



"Ready to close" contacts PF.

### "Ready to close" contact PF

The "ready to close" position of the circuit breaker is indicated by a mechanical indicator and a PF changeover contact. This signal indicates that all the following are valid:

- The circuit breaker is in the OFF position
- The spring mechanism is charged
- A maintained opening order is not present:
- MX energised
- Fault trip
- Remote tripping MN
- Device not completely racked in
- Device locked in OFF position
- Device interlocked with a second device

#### Characteristics

Maximum number	1	
Breaking capacity (A)	Standard	Minimum load: 100 mA/24 V
	p.f.: 0.3	
AC12/DC12	V AC	240/380
		480
	V DC	24/48
		125
	250	0.15

DB100809-16



MN voltage release.

### Instantaneous voltage releases MN

The MN release instantaneously opens the circuit breaker when its supply voltage drops to a value between 35 % and 70 % of its rated voltage. If there is no supply on the release, it is impossible to close the circuit breaker, either manually or electrically. Any attempt to close the circuit breaker has no effect on the main contacts. Circuit breaker closing is enabled again when the supply voltage of the release returns to 85% of its rated value.

#### Characteristics

Power supply	V AC 50/60 Hz	24 - 48 - 100/130 - 200/250 - 380/480
	V DC	24/30 - 48/60 - 100/130 - 200/250
Operating threshold	Opening	0.35 to 0.7 Un
	Closing	0.85 Un
Consumption (VA or W)		Pick-up: 200 (200 ms)      Hold: 4.5
MN consumption		Pick-up: 200 (200 ms)      Hold: 4.5
with delay unit (VA or W)		
Circuit-breaker response time at Un		40 ms ±5

056422N



MN delay unit.

### MN delay units

To eliminate circuit-breaker nuisance tripping during short voltage dips, operation of the MN release can be delayed. This function is achieved by adding an external delay unit in the MN voltage-release circuit. Two versions are available, adjustable and non-adjustable.

#### Characteristics

Power supply	Non-adjustable	100/130 - 200/250
	Adjustable	48/60 - 100/130 - 200/250 - 380/480
Operating threshold	Opening	0.35 to 0.7 Un
	Closing	0.85 Un
Delay unit consumption		Pick-up: 200 (200 ms)      Hold: 4.5
Circuit-breaker response time at Un	Non-adjustable	0.25 s
	Adjustable	0.5 s - 0.9 s - 1.5 s - 3 s

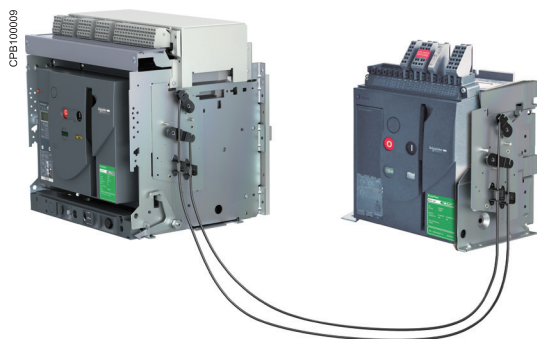

Interlocking of two EasyPact circuit breakers using cable.

### Interlocking of two EasyPact SPS/MVS devices using cables

For cable interlocking, the circuit breakers may be mounted one above the other or side-by-side. The interlocked devices may be fixed or drawout, three-pole or four-pole, and have different ratings.

#### Interlocking between two devices

This function requires:

- An adaptation fixture on the right side of each device
- A set of cables with no-slip adjustments
- The use of a mechanical operation counter CDM is compulsory

The maximum distance between the fixing planes (vertical or horizontal) is 2000 mm.

#### Installation

The adaptation fixtures, sets of cables and circuit breakers or switch-disconnectors are supplied separately, ready for assembly by the customer.

Installation conditions for cable interlocking systems:

- Cable length: 2.5 m
- Radius of curvature: 100 mm
- Maximum number of curves: 3

Possible combinations of "Normal" and "Replacement" source circuit breakers		
"Normal" N	"Replacement" R	
SPS08 to SPS16 Ratings 800...1600A	■ SPS08 to SPS16	■ MVS08 to MVS40
MVS08 to MVS40 Ratings 800...4000A	■	■

All combinations of two EasyPact SPS and EasyPact MVS devices are possible, whatever the rating or size of the devices.

PB104740

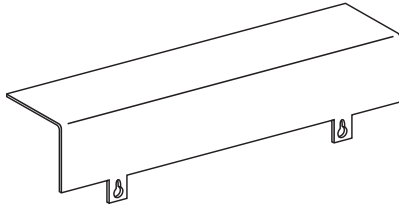

### Auxiliary terminal shield CB

Optional equipment mounted on the chassis, the shield prevents access to the terminal block of the electrical auxiliaries.

PB10432A32

DB10173

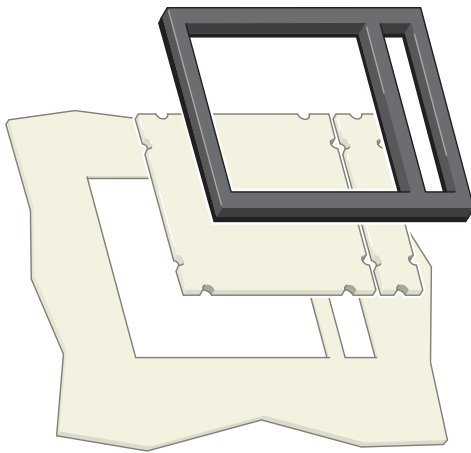

### Escutcheon CDP

Standard equipment mounted on the door of the cubicle, the escutcheon increases the degree of protection to IP 40 (circuit breaker installed free standing: IP30) . It is available in fixed and drawout versions.

### Blanking plate for escutcheon OP

Used with the escutcheon, this option closes off the door cut-out of a cubicle not yet equipped with a device. It adapts to drawout devices.

*Escutcheon CDP with blanking plate.*

PB10076-42

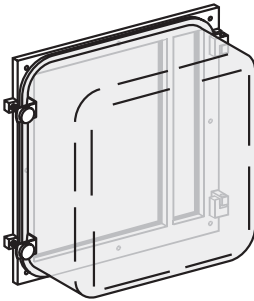

### Transparent cover for escutcheon CP

Optional equipment mounted on the escutcheon, the cover is hinged and secured by a screw. It increases the degree of protection to IP54, IK10. It adapts to drawout devices.

*Transparent cover CP for escutcheon.*





# Installation recommendations



---

<i>Functions and characteristics</i>	<i>A-1</i>
<b>Operating conditions</b>	<b>B-2</b>
<b>Installation in switchboard</b>	<b>B-3</b>
<b>Door interlock catch</b>	<b>B-5</b>
<b>Control wiring</b>	<b>B-6</b>
<b>Power connection</b>	<b>B-7</b>
<b>Recommended busbars drilling</b>	<b>B-9</b>
<b>Busbar sizing</b>	<b>B-10</b>
<b>Temperature derating</b>	
<b>Power dissipation</b>	<b>B-11</b>
<i>Dimensions and connection</i>	<i>C-1</i>
<i>Electrical diagrams</i>	<i>D-1</i>
<i>Additional characteristics</i>	<i>E-1</i>
<i>Catalogue numbers and order form</i>	<i>F-1</i>

## Installation recommendations

## Operating conditions

EasyPact SPS circuit breakers have been tested for operation in industrial atmospheres. It is recommended that the equipment be cooled or heated to the proper operating temperature and kept free of excessive vibration and dust.

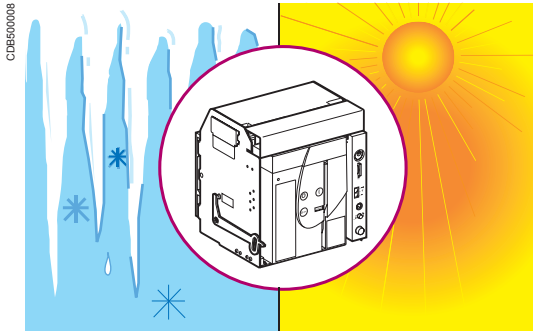

### Ambient temperature

EasyPact SPS devices can operate under the following temperature conditions:

- The electrical and mechanical characteristics are stipulated for an ambient temperature of  $-5^{\circ}\text{C}$  to  $+60^{\circ}\text{C}$
- Circuit-breaker closing is guaranteed down to  $-35^{\circ}\text{C}$

Storage conditions are as follows:

- $-35$  to  $+85^{\circ}\text{C}$  for a EasyPact SPS device without its control unit
- $-25^{\circ}\text{C}$  to  $+85^{\circ}\text{C}$  for the control unit

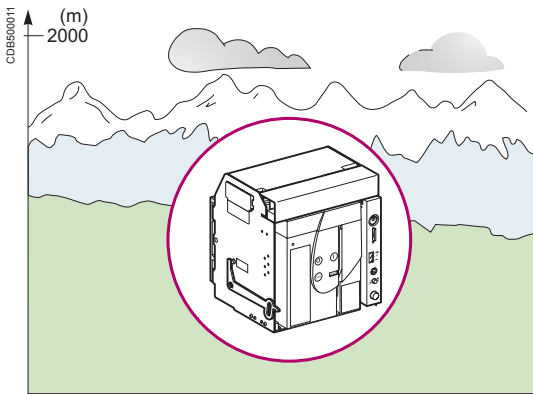

### Altitude

At altitudes higher than 2000 metres, the modifications in the ambient air (electrical resistance, cooling capacity) lower the following characteristics as follows:

Altitude (m)	2000	3000
Impulse withstand voltage uimp (kV)	12	11
Rated insulation voltage (Ui)	1000	900
Maximum rated operational voltage 50/60 Hz Ue (V)	440	440
Rated current 40°C	1 x In	0.99 x In

Intermediate values may be obtained by interpolation.

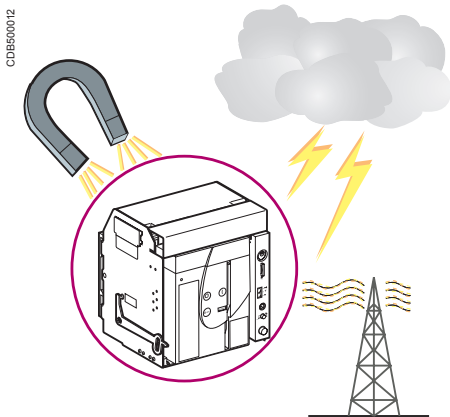

### Electromagnetic disturbances

EasyPact SPS devices are protected against:

- Overvoltages caused by devices that generate electromagnetic disturbances
- Overvoltages caused by atmospheric disturbances or by a distribution-system outage (e.g. failure of a lighting system)
- Devices emitting radio waves (radios, walkie-talkies, radar, etc.)
- Electrostatic discharges produced by users

EasyPact SPS devices have successfully passed the electromagnetic-compatibility tests (EMC) defined by the following international standards:

- IEC 60947-2, appendix F

The above tests guarantee that:

- No nuisance tripping occurs
- Tripping times are respected



# Installation in switchboard

## Possible positions

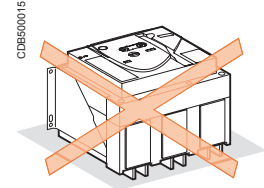
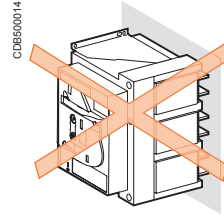
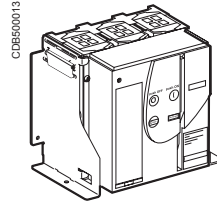

## Power supply

EasyPact SPS devices can be supplied either from the top or from the bottom without reduction in performance, in order to facilitate connection when installed in a switchboard.

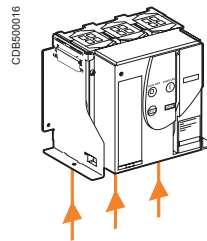

## Mounting the circuit-breaker

It is important to distribute the weight of the device uniformly over a rigid mounting surface such as rails or a base plate.

This mounting plane should be perfectly flat (tolerance on support flatness: 2 mm). This eliminates any risk of deformation which could interfere with correct operation of the circuit breaker.

EasyPact devices can also be mounted on a vertical plane using the special brackets.

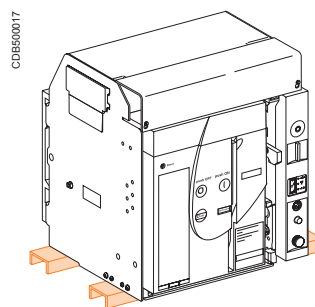

Mounting on rails.

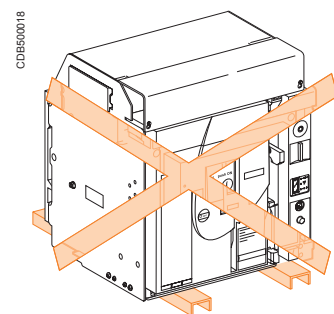

## Partitions

Sufficient openings must be provided in partitions to ensure good air circulation around the circuit breaker; Any partition between upstream and downstream connections of the device must be made of nonmagnetic material.

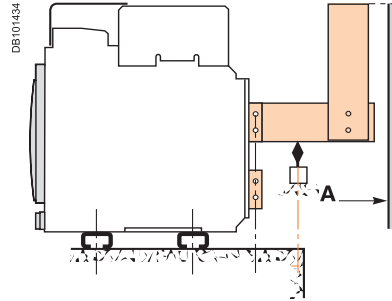

A : Non magnetic material.



## Busbars

The mechanical connection must exclude the possibility of formation of a magnetic loop around a conductor.

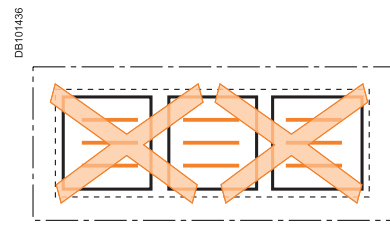
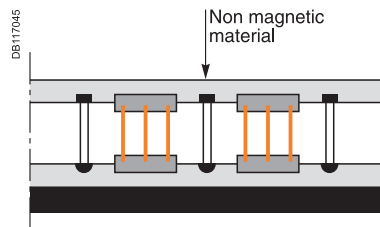

For live busbars installed immediately above the circuit breaker (respecting the 100 mm safety clearance), the distance between bars must be 65 mm minimum

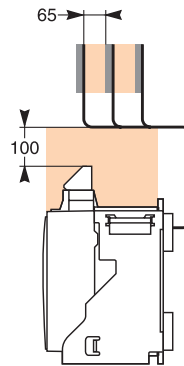

## Interphase barrier

If the insulation distance between phases is not sufficient ( $\leq 14$  mm), it is advised to install phase barriers (taking into account the safety clearances).

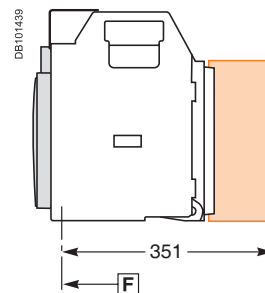
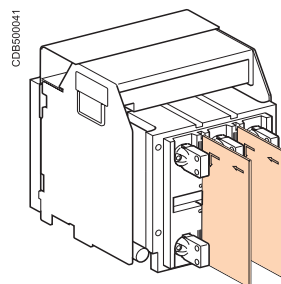

# Door interlock catch

## Door interlock VPEC

Mounted on the right or left-hand side of the chassis, this device inhibits opening of the cubicle door when the circuit breaker is in "connected" or "test" position. If the breaker is put in the "connected" position with the door open, the door may be closed without having to disconnect the circuit breaker.

### Dimensions (mm)

Type	(1)	(2)
SPS08-16 (3P)	135	168
SPS08-16(4P)	205	168

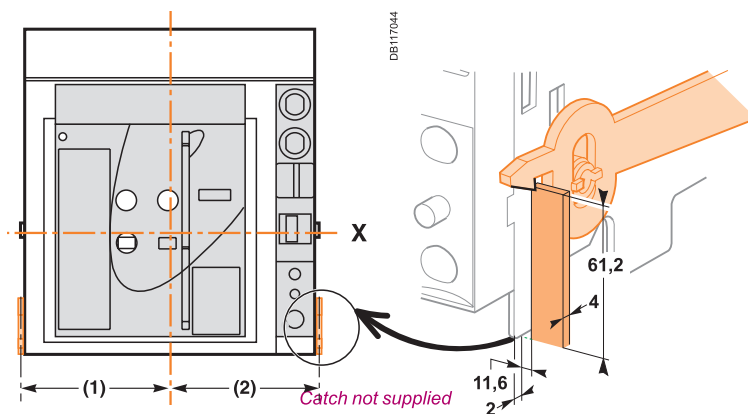

**Breaker in "connected" or "test" position**  
Door cannot be opened

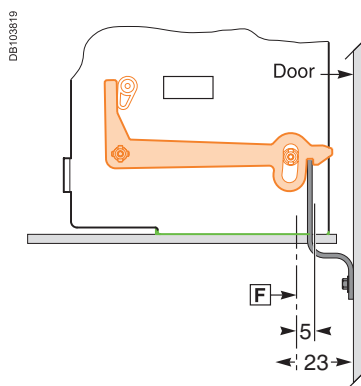

**Breaker in "disconnected" position**  
Door can be opened

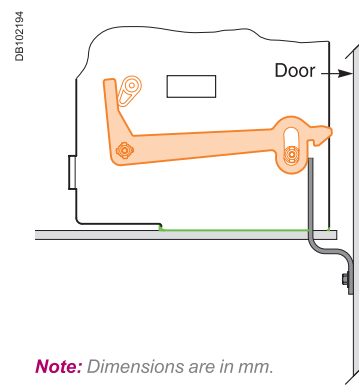

*Note: Dimensions are in mm.*

**Note:** The door interlock can either be mounted on the right side or the left side of the breaker.

**F**: Datum.

## Wiring of voltage releases

During pick-up, the power consumed is approximately 150 to 200 VA. For low control voltages ( 24, 48 V), maximum cable lengths are imposed by the voltage and the cross-sectional area of cables.

### Recommended maximum cable lengths (meter).

		24 V		48 V	
		2,5 mm <sup>2</sup>	1,5 mm <sup>2</sup>	2,5 mm <sup>2</sup>	1,5 mm <sup>2</sup>
MN	U source 100 %	58	35	280	165
	U source 85 %	16	10	75	45
MX-XF	U source 100 %	115	70	550	330
	U source 85 %	75	44	350	210

**Note:** The indicated length is that of each of the two wires.





# Power connection

## Cables connections

If cables are used for the power connections, make sure that they do not apply excessive mechanical forces to the circuit breaker terminals.

For this, make the connections as follows:

- Extend the circuit breaker terminals using short bars designed and installed according to the recommendations for bar-type power connections:
  - For a single cable, use solution **B** opposite
  - For multiple cables, use solution **C** opposite
- In all cases, follow the general rules for connections to busbars:
  - Position the cable lugs before inserting the bolts
  - The cables should be firmly secured to the framework **E**

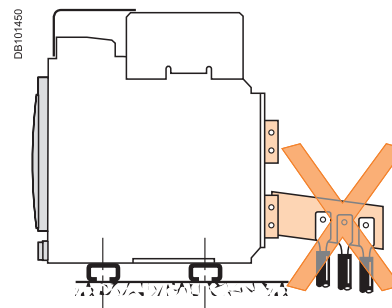
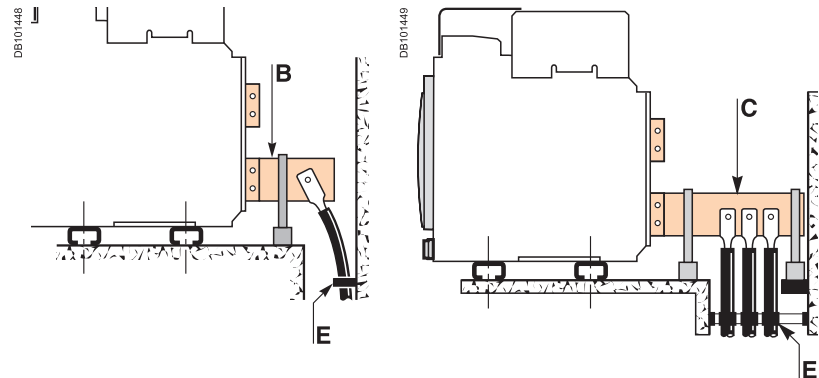

## Busbars connections

The busbars should be suitably adjusted to ensure that the connection points are positioned on the terminals before the bolts are inserted **B**.

The connections are held by the support which is solidly fixed to the framework of the switchboard, such that the circuit breaker terminals do not have to support its weight **C**. (This support should be placed close to the terminals).

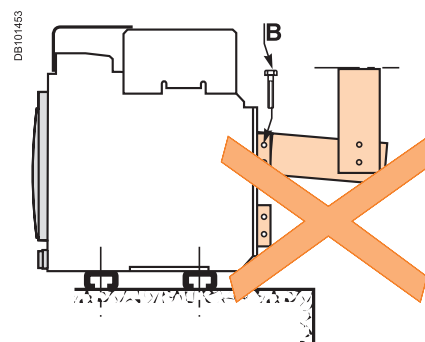
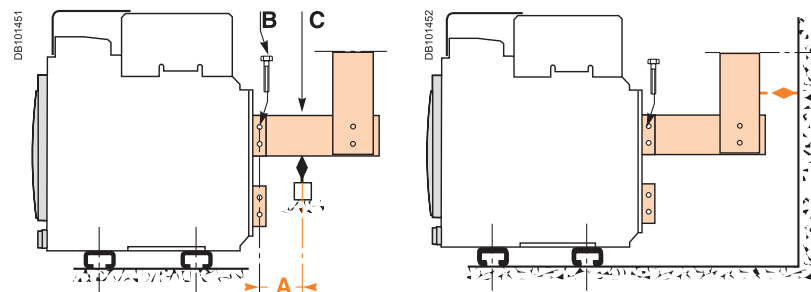

## Electrodynamic stresses

The first busbar support or spacer shall be situated within a maximum distance from the connection point of the breaker (see table below). This distance must be respected so that the connection can withstand the electrodynamic stresses between phases in the event of a short circuit.

**Maximum distance A between busbar to circuit breaker connection and the first busbar support or spacer with respect to the value of the prospective short-circuit current.**

Isc (kA)	30	50
Distance A (mm)	350	300



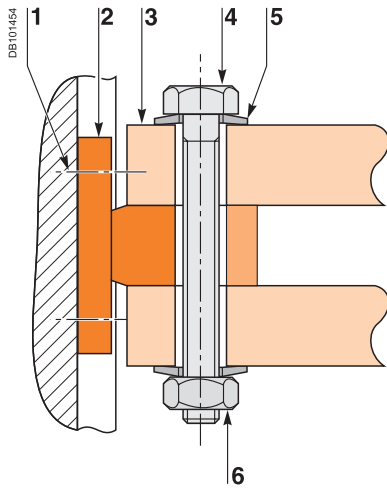

- 1 Terminal screw factory-tightened to 16 Nm.
- 2 Breaker terminal.
- 3 Busbar.
- 4 Bolt.
- 5 Washer.
- 6 Nut.

**Clamping**

Correct clamping of busbars depends amongst other things, on the tightening torques used for the nuts and bolts. Over-tightening may have the same consequences as under-tightening.

For connecting busbars (Cu ETP-NFA51-100) to the circuit breaker, the tightening torques to be used are shown in the table below.

These values are for use with copper busbars and steel nuts and bolts, class 8.8. The same torques can be used with AGS-T52 quality aluminium bars (French standard NFA 02-104 or American National Standard H-35-1).

**Examples**

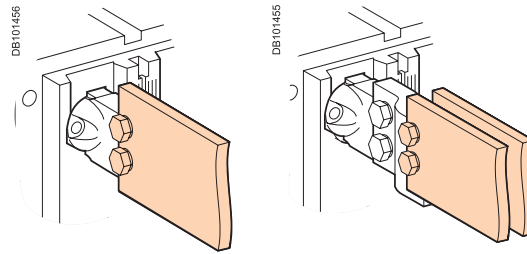

Tightening torques			
Ø (mm) Nominal	Ø (mm) Drilling	Tightening torques (Nm) with grower or flat washers	Tightening torques (Nm) with contact or corrugate washers
10	11	37.5	50

**Busbar drilling**

**Examples**

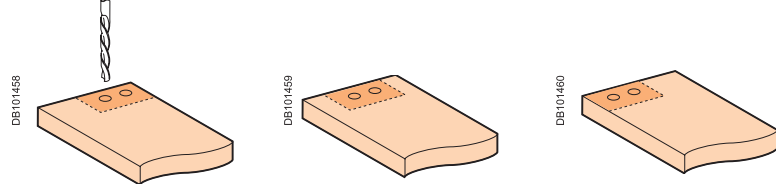

**Isolation distance**

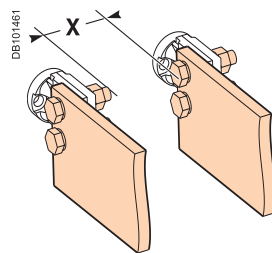

**Dimensions (mm)**

Ui	X min
600 V	8mm
1000V	14mm

When bending busbars maintain the radius indicated below (a smaller radius would cause cracks).

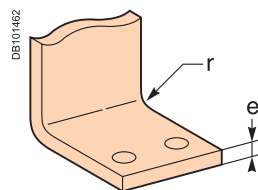

**Dimensions (mm)**

e	Radius of curvature r	
	Min	Recommended
5	5	7.5
10	15	18 to 20



# Recommended busbars drilling

## EasyPact SPS08 to SPS16

### Rear connection

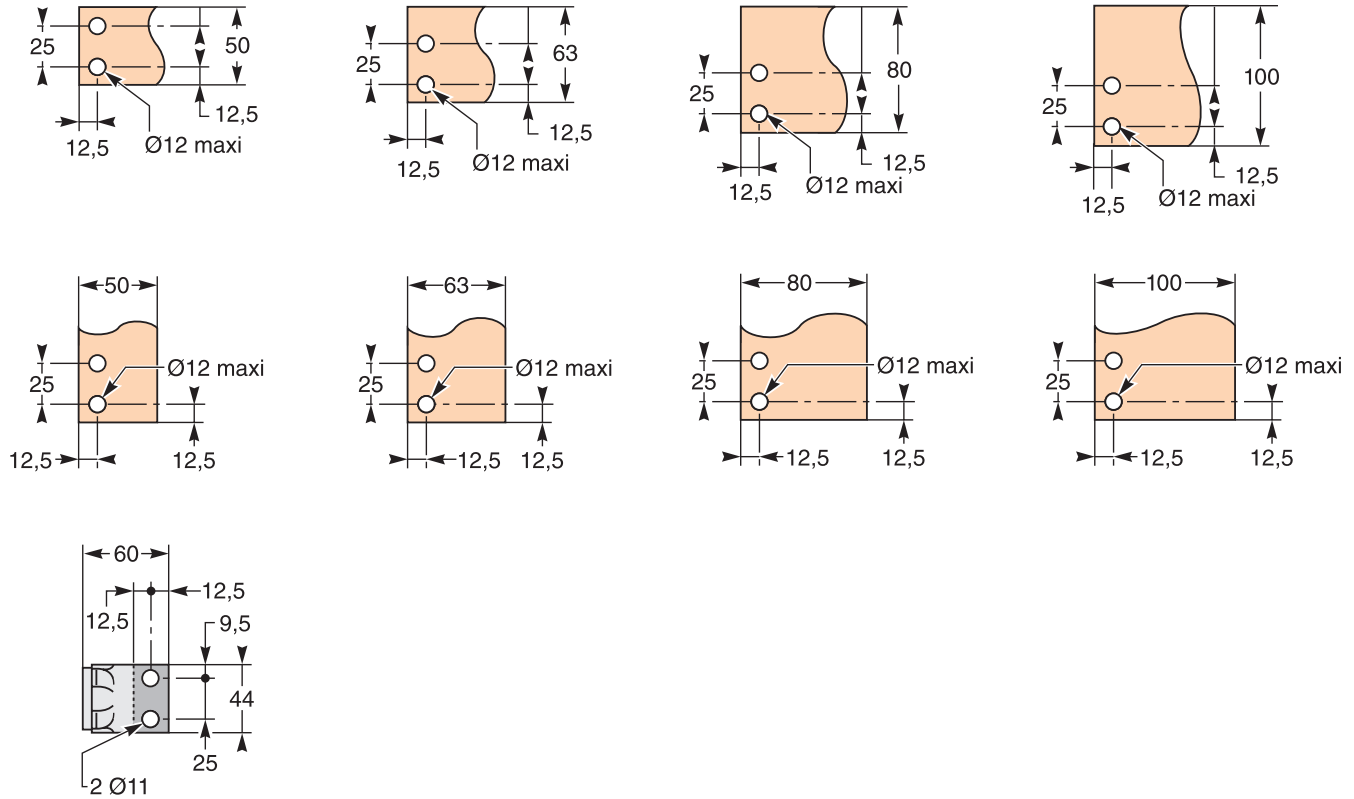

### Rear connection with spacers ( SPS12 / SPS16 )

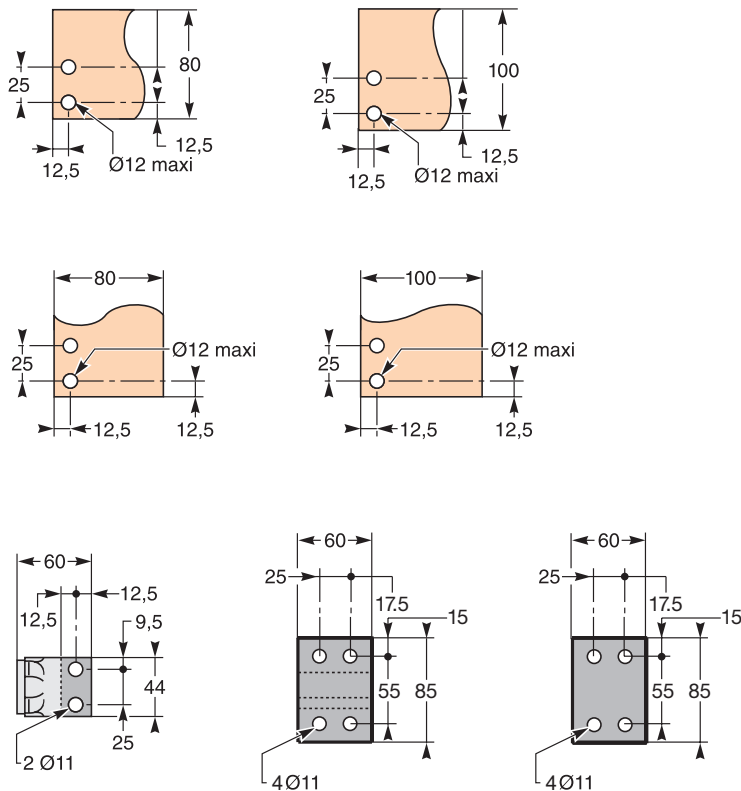

**Basis of tables:**

- Maximum permissible busbars temperature: 100°C
- $T_i$ : temperature around the circuit breaker and its connection
- Busbar material is unpainted Copper/ Aluminium

## Rear vertical connection

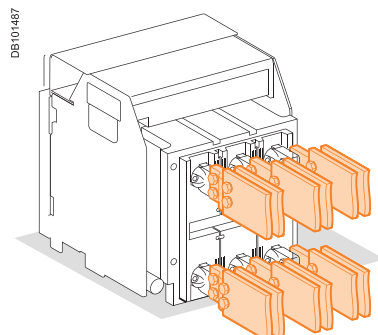

Unpainted Copper (Vertical connection)			
EasyPact	Maximum service current	$T_i$ : 40°C No. of 5 mm thick bars	$T_i$ : 50°C No. of 5 mm thick bars
SPS08	800	2b.50 x 5	2b.50 x 5
SPS10	1000	2b.50 x 5	2b.50 x 5
SPS12	1250	2b.63 x 5	3b.50 x 5
SPS16	1600	3b.63 x 5	3b.63 x 5

Unpainted Aluminium (Vertical connection)		
EasyPact	Maximum service current	$T_i$ : 50°C
SPS08	800	1b.80 x 10
SPS10	1000	1b.100 x 10
SPS12	1250	2b.100 x 6
SPS16	1600	2b 80 x 10

### Example

**Conditions:**

- Drawout version
- Vertical busbars
- $T_i$ : 50°C
- Service current: 1600 A

**Solution:**

For  $T_i = 50^\circ\text{C}$ , use an SPS16 which can be connected with 3 bars-63 x 5 mm Copper (or) 2 bars-80x10mm Aluminium

*Note: The values indicated in these tables have been extrapolated from test data and theoretical calculations. These tables are only intended as a guide and cannot replace industrial experience or a temperature rise test.*

# Temperature derating Power dissipation

## Temperature derating

The table below indicates the maximum current rating, for each connection type, as a function of  $T_i$  around the circuit breaker and the busbars.

For  $T_i$  greater than 60°C, consult us.

$T_i$ : temperature around the circuit breaker and its connection.

Version	Drawout					Fixed				
	Rear vertical					Rear vertical				
Temp. $T_i$	40 °C	45 °C	50 °C	55 °C	60 °C	40 °C	45 °C	50 °C	55 °C	60 °C
SPS (50kA)										
SPS08F	800					800				
SPS10F	1000					1000				
SPS12F	1250				1225	1250				
SPS16F	1600			1560	1510	1600				

## Power dissipation

Total power dissipation is the value measured at  $I_N$ , 50/60 Hz, for a 3 pole or 4 pole breaker (values above the power  $P = 3RI^2$ ). The resistance between input / output is the value measured per pole (cold state).

Type	Draw-out	Fixed
50kA	Input/output resistance (μohm)	Input/output resistance (μohm)
SPS08F	38	26
SPS10F	38	26
SPS12F	38	26
SPS16F	36	26

# Dimensions and connection



---

<i>Functions and characteristics</i>	<b>A-1</b>
<i>Installation recommendations</i>	<b>B-1</b>
<b>SPS08 to SPS16 circuit breakers</b>	<b>C-2</b>
Fixed 3/4-poles device	C-2
Drawout 3/4-poles device	C-4
<b>External modules</b>	<b>C-6</b>
<i>Electrical diagrams</i>	<b>D-1</b>
<i>Additional characteristics</i>	<b>E-1</b>
<i>Catalogue numbers and order form</i>	<b>F-1</b>

### Dimensions

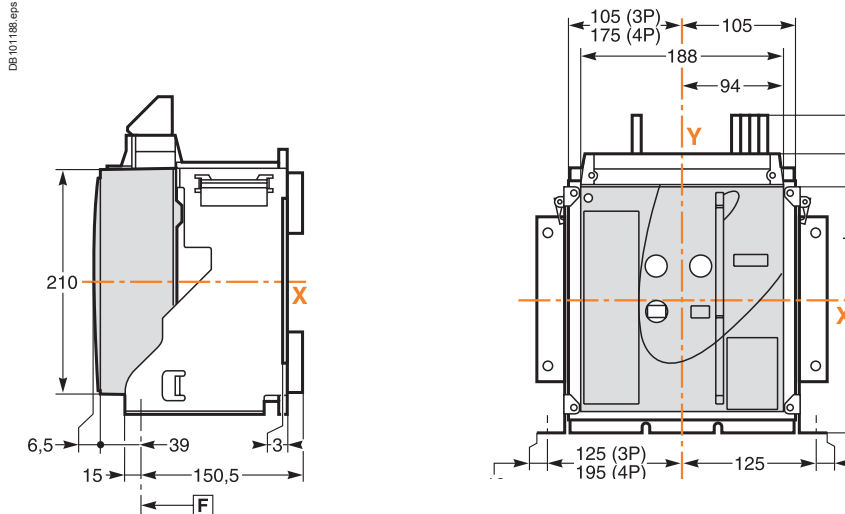

### Bottom mounting (on base plate or rails)

### Rear mounting detail (on upright or backplate)

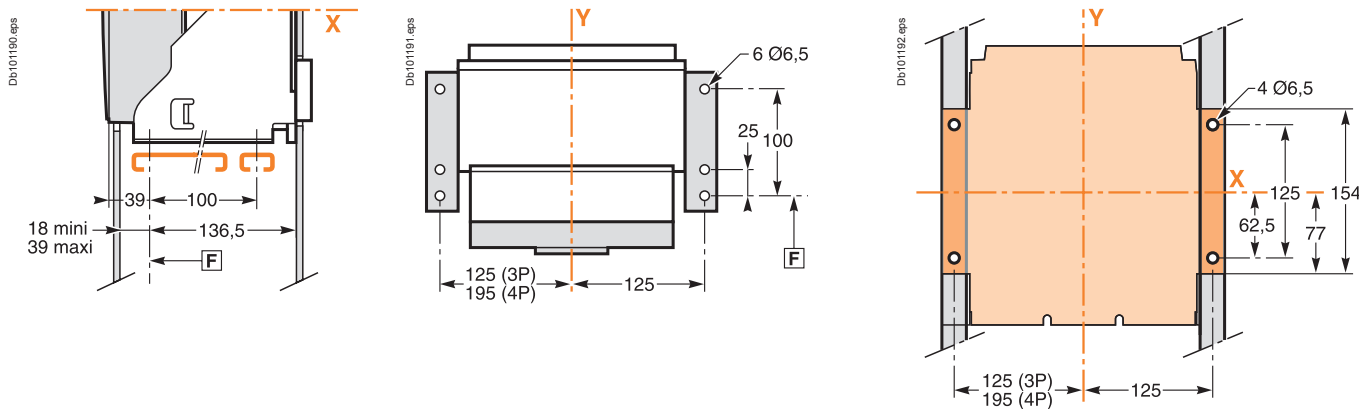

### Safety clearances

### Door cutout

### Rear panel cutout

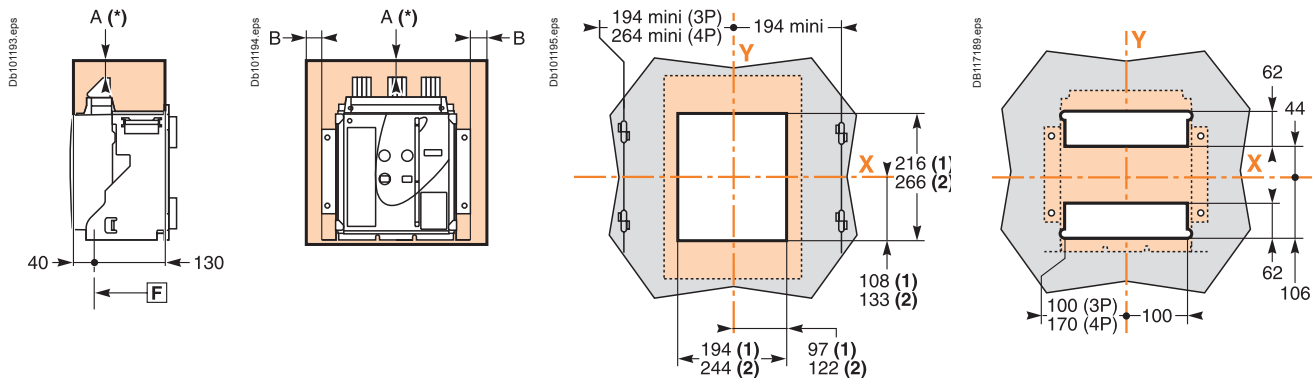

### For voltages < 690 V

	Parts		Energised
	Insulated	Metal	
A	0	0	100
B	0	0	60

**F**: datum.

(1) Without escutcheon.  
(2) With escutcheon.

**Note:** X and Y are the symmetry planes for a 3-pole device.  
A(\*) An overhead clearance of 50 mm is required to remove the arc chutes.  
An overhead clearance of 20 mm is required to remove the terminal block.





## Connections

### Vertical rear connection SPS08F/SPS10F

### Detail

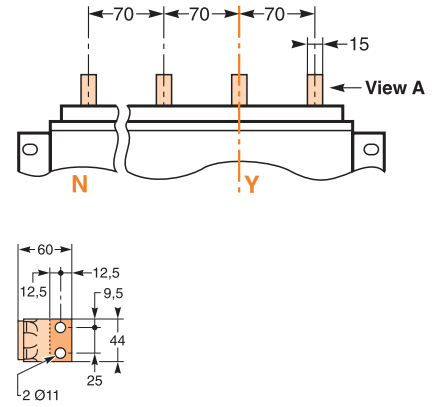
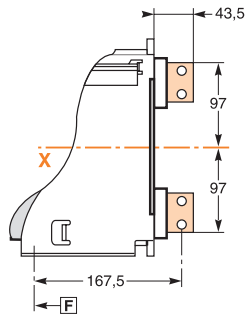
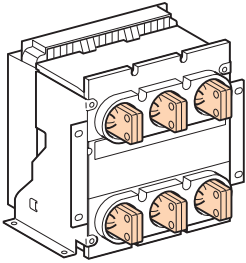

### Vertical rear connection SPS12F/SPS16F(3P)

### Detail

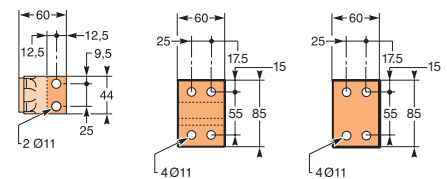
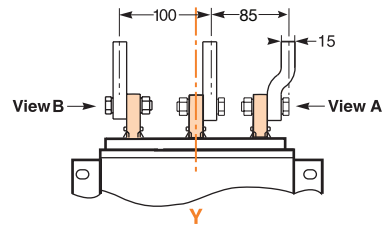
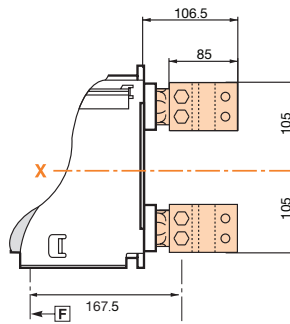
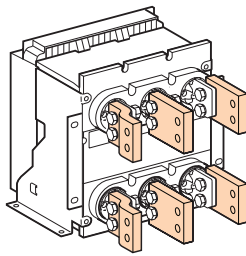

View A detail.

View B detail.

### Vertical rear connection SPS12F/SPS16F (4P)

### Detail

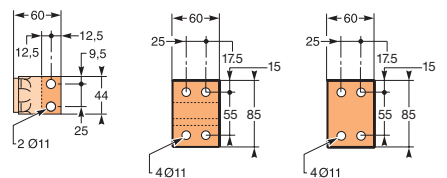
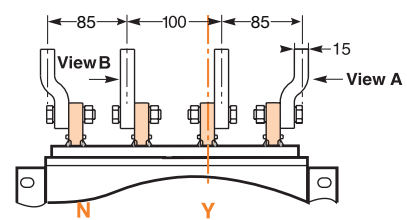
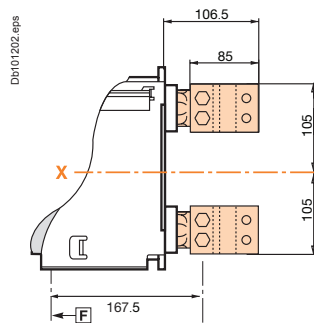
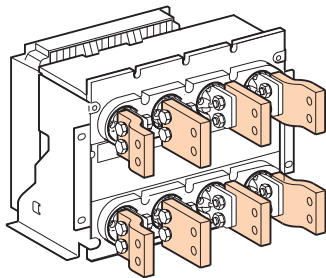

View A detail.

View B detail.

**Note:** recommended connection screws: **M10** class 8.8.  
Tightening torque: **50 Nm** with contact washer.



### Dimensions

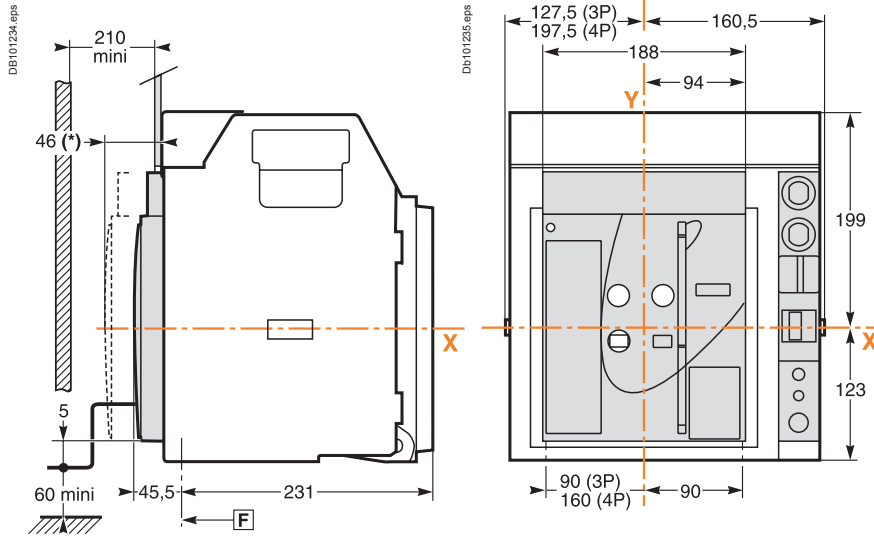

(\*) Disconnected position.

### Bottom mounting (on base plate or rails)

### Rear mounting detail (on upright or backplate)

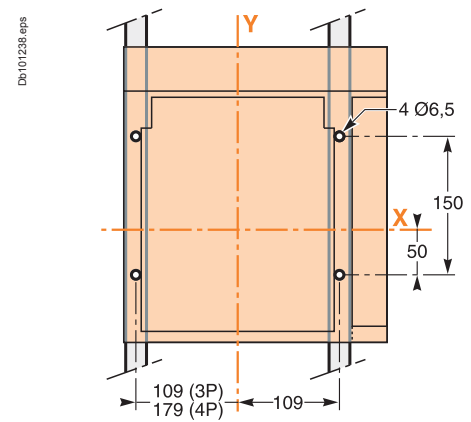
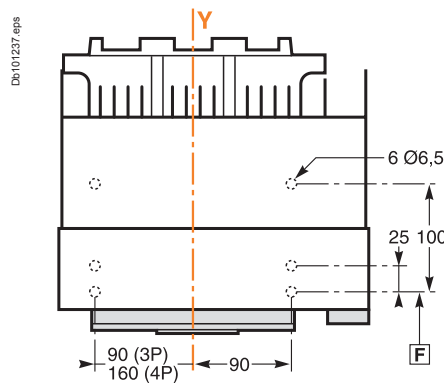
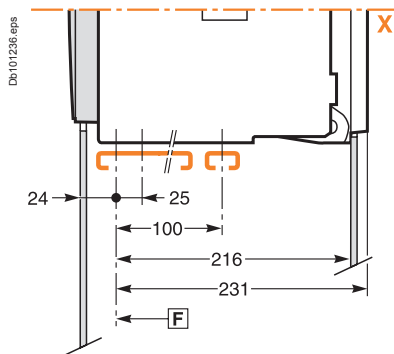

### Safety clearances

### Door cutout

### Rear panel cutout

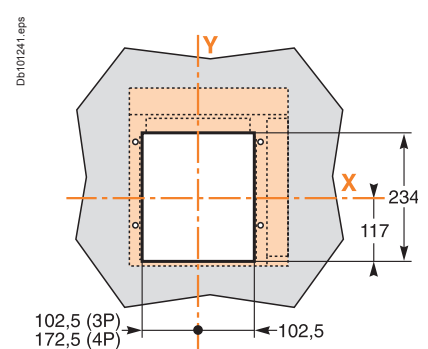
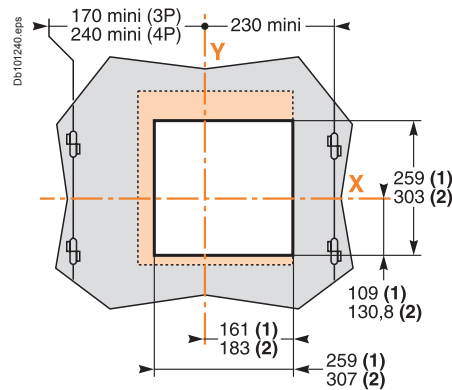
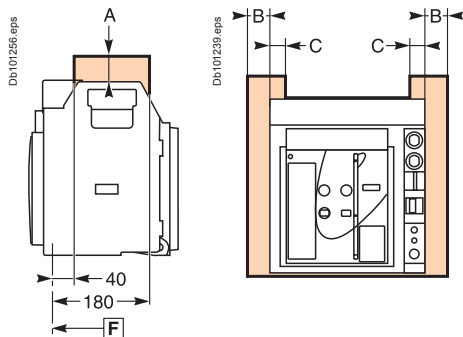

For voltages ≤ 690 V

	Parts		
	Insulated	Metal	Energised
A	0	0	30
B	10	10	60
C	0	0	30

**F** : datum.

(1) Without escutcheon.

(2) With escutcheon.

Note: X and Y are the symmetry planes for a 3-pole device.



## Connections

### Vertical rear connection SPS08F/SPS10F

### Detail

Db 01246 eps

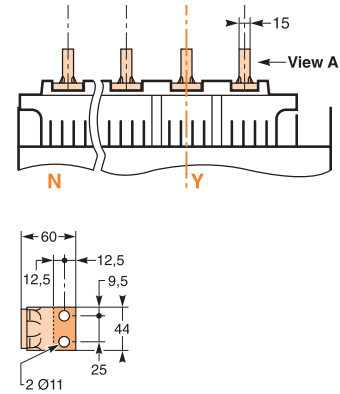
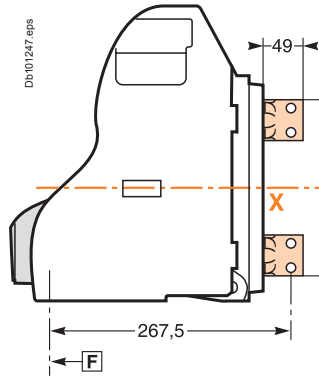
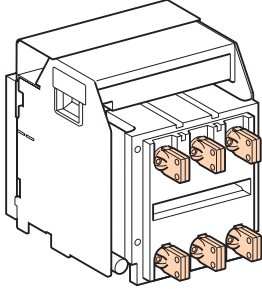

### Vertical rear connection SPS12F/SPS16F(3P)

### Detail

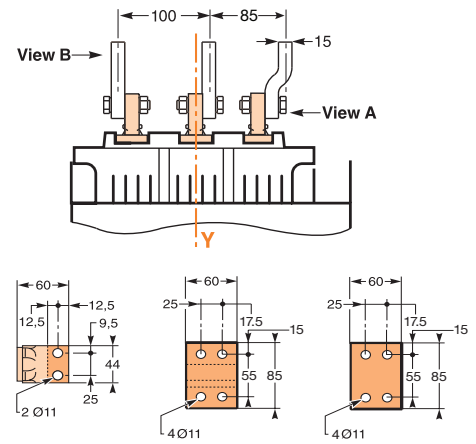
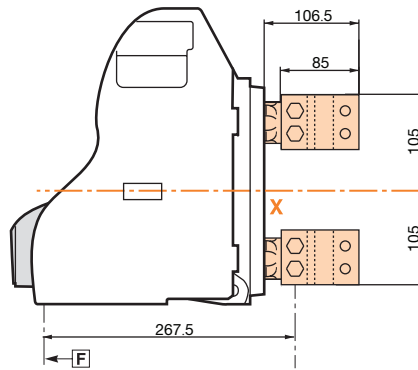
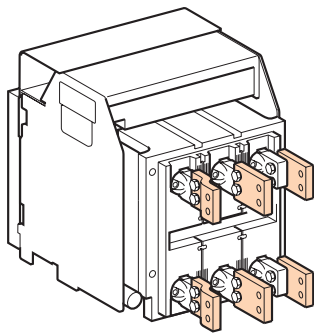

View A detail.

View B detail.

### Vertical rear connection SPS12F/SPS16F(4P)

### Detail

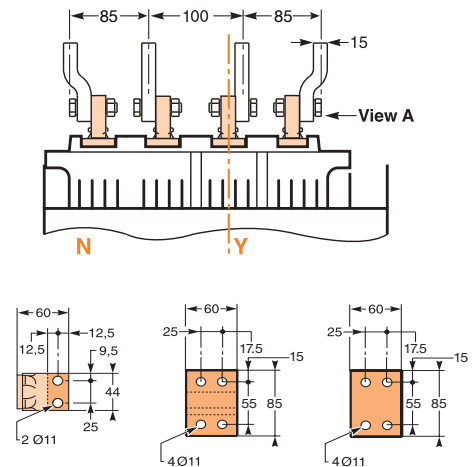
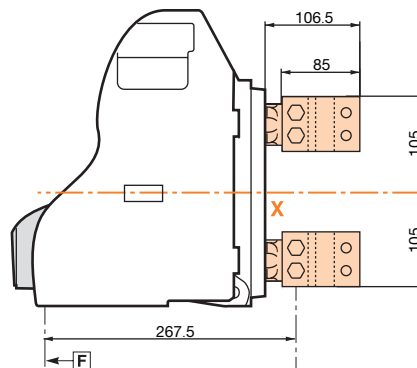
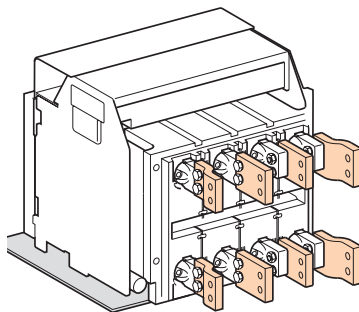



View A detail.

View B detail.

**Note:** recommended connection screws: **M10** class 8.8.  
Tightening torque: **50 Nm** with contact washer.



## Connection of auxiliary wiring to terminal block

-  S : 0,6 mm<sup>2</sup>
-  S : 2,5 mm<sup>2</sup>

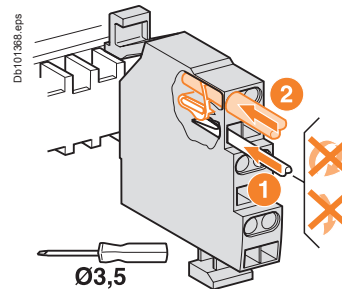
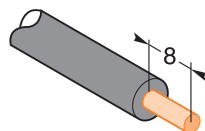

One conductor only per connection point.

## Delay unit for MN release

### Mounting

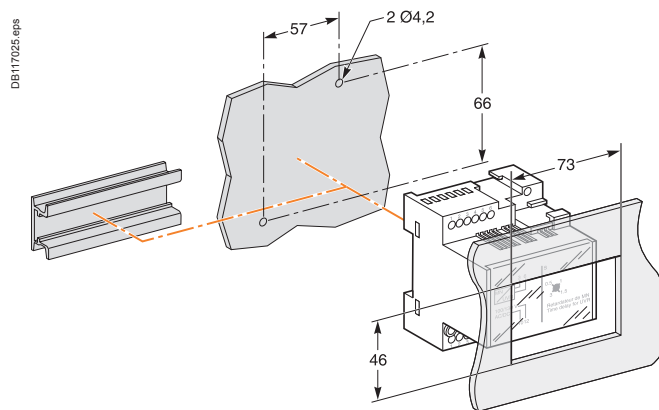
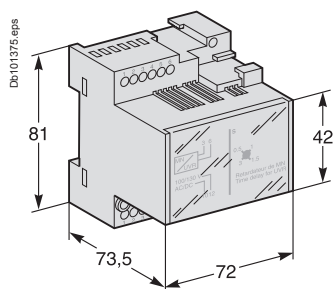

## External sensor for external neutral

### Dimensions

400/1600 A (SPS08 to SPS16)

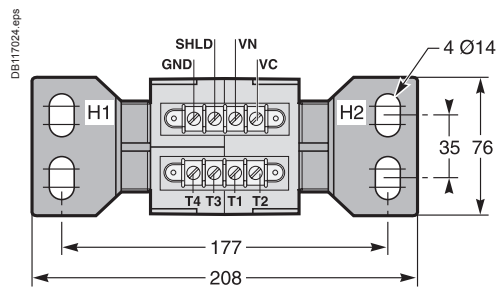

High: 162 mm.

### Installation

400/2000 A (SPS08 to SPS16)

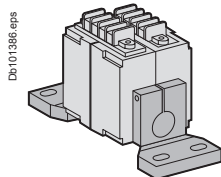



# Electrical diagrams





---

<i>Functions and characteristics</i>	<b>A-1</b>
<i>Installation recommendations</i>	<b>B-1</b>
<i>Dimensions and connection</i>	<b>C-1</b>
<b>EasyPact SPS08 to SPS16</b>	<b>D-2</b>
Fixed and drawout devices	D-2
<b>EasyPact SPS</b>	<b>D-4</b>
Earth-fault protection/Neutral protection	D-4
Zone Selective Interlocking	D-5
<i>Additional characteristics</i>	<b>E-1</b>
<i>Catalogue numbers and order form</i>	<b>F-1</b>



The diagram is shown with circuits de-energised, all devices open, connected and charged and relays in normal position.

### Power

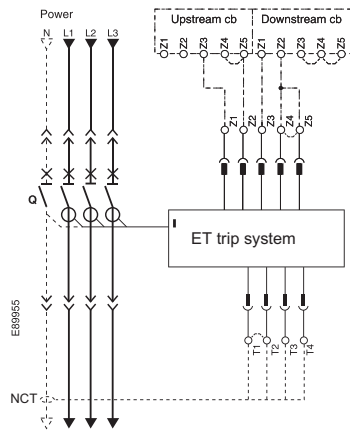

Note: Z1...Z5 & T1 ...T4 are available only in ET6G trip system

### Remote operation

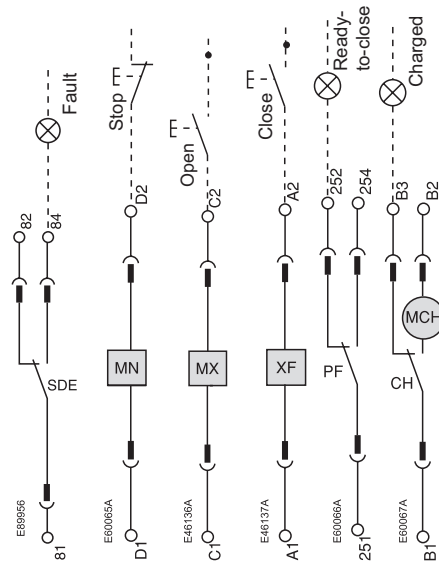

### ET trip system

UC1		UC2	
○	Z5		
○	Z3	○	T3
○	Z4	○	T4
○	Z1	○	T1
○	Z2	○	T2

### Remote operation

SDE	MN	MX	XF	PF	MCH
○	○	○	○	○	○
84	D2	C2	A2	254	B2
82		C3	A3	252	B3
81	D1	C1	A1	251	B1

### ET/ETA/ETV trip system

**UC1 :**  
 Z1-Z5 zone selective interlocking  
 Z1=ZSI OUT SOURCE  
 Z2=ZSI OUT ; Z3 = ZSI IN SOURCE  
 Z4 =ZSI IN ST (short time)  
 Z5 =ZSI IN GF (earth fault)

**UC2 :**  
 T1, T2, T3, T4=external neutral

### Remote operation

**SDE:** Fault-trip indication contact (supplied as standard)  
**MN:** Undervoltage release  
**MX:** Shunt release (standard for Electrical breaker)  
**XF:** Closing release (standard for Electrical breaker)  
**PF:** "Ready to close"contact  
**MCH:** Gear motor (standard for Electrical breaker)

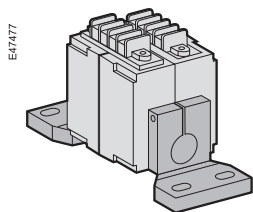

External sensor (CT).

### External sensors ( Neutral CT)

External sensor for earth-fault protection

The sensors, used with the 3P circuit breakers, are installed on the neutral conductor for:

- Residual type earth-fault protection(ET 6G trip system)

The rating of the sensor (CT) must be compatible with the rating of the circuit breaker:

- SPS08 to SPS16 : CT 400/1600A;





### Indication contacts

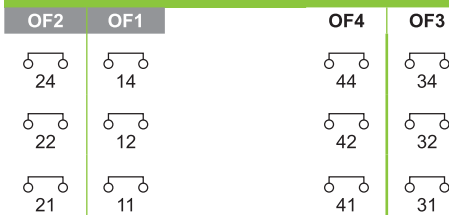
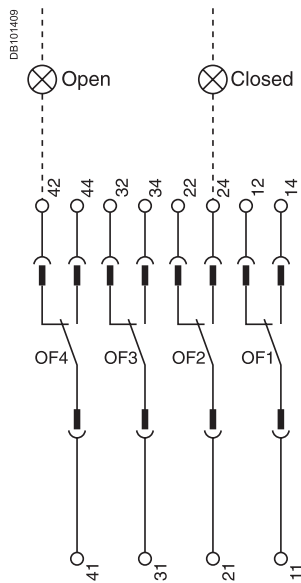

Standard

Optional

### Chassis contacts

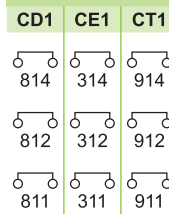
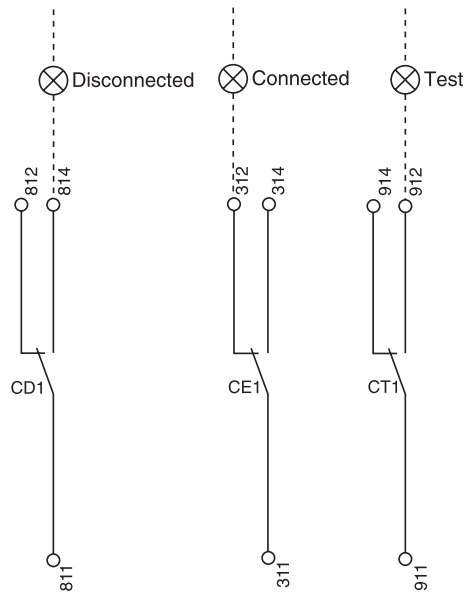

Optional

### Indication contacts

<b>OF2</b>	Standard
<b>OF1</b>	ON/OFF Indication contacts

<b>OF4</b>	Optional
<b>OF3</b>	ON/OFF Indication contacts

### Chassis contacts

<b>CD1</b> Disconnected Position Contact	<b>CE1</b> Connected Position Contact	<b>CT1</b> Test Position Contact
--	---	--

Key:

Drawout device only

SDE, OF1, OF2 supplied as standard

Interconnected connections  
(only one wire per connection point)



# EasyPact SPS

## Earth-fault protection

### Neutral Protection

#### External sensor (CT) for residual earth-fault protection

##### Connection of current-transformer secondary circuit for external neutral

EasyPact SPS equipped with a ET6G:

- Shielded cable with 2 twisted pairs
- T1 twisted with T2
- Maximum length 4 meters
- Cable cross-sectional area 0.4 to 1.5 mm<sup>2</sup>
- Recommended cable: Belden 9552 or equivalent

For proper wiring of neutral CT, refer to instruction Bulletin 48041-082-03 shipped with it.

Do not remove factory-installed jumper between T1 and T2 unless neutral CT is connected.

If supply is via the top, follow the schematics.

If supply is via the bottom, control wiring is identical; for the power wiring, H1 is connected to the source side, H2 to the load side.

For four-pole versions, for residual earth-fault protection, the current transformer for the external neutral is not necessary.

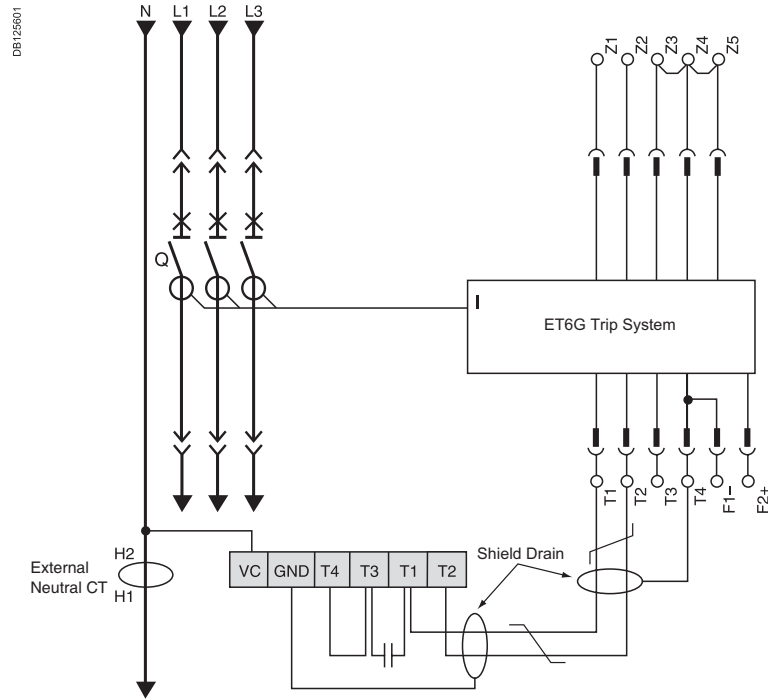

#### Neutral protection

- Three pole circuit breaker:
  - Neutral protection is impossible
- Four pole circuit breaker:
  - The current transformer for external neutral is not necessary

### Zone selective interlocking

Zone-selective interlocking is used to reduce the electrodynamic forces exerted on the installation by shortening the time required to clear faults, while maintaining time discrimination between the various devices.

A pilot wire interconnects a number of circuit breakers equipped with ET range of trip system, as illustrated in the diagram above.

The control unit detecting a fault sends a signal upstream and checks for a signal arriving from downstream. If there is a signal from downstream, the circuit breaker remains closed for the full duration of its tripping delay. If there is no signal from downstream, the circuit breaker opens immediately, regardless of the tripping-delay setting.

**Fault 1.**

Only circuit breaker A detects the fault. Because it receives no signal from downstream, it opens immediately, regardless of its tripping delay set to 0.3.

**Fault 2.**

Circuit breakers A and B detect the fault. Circuit breaker A receives a signal from B and remains closed for the full duration of its tripping delay set to 0.3. Circuit breaker B does not receive a signal from downstream and opens immediately, in spite of its tripping delay set to 0.2.

**Wiring**

- Maximum impedance: 2.7 Ω / 300 m
- Capacity of connectors: 0.4 to 2.5 mm<sup>2</sup>
- Wires: single or multicore
- Maximum length: 3000 m
- Limits to device interconnection:
  - The common ZSI - OUT (Z1) and the output ZSI - OUT (Z2) can be connected to a maximum of 10 upstream device
  - A maximum of 100 downstream devices may be connected to the common ZSI - IN (Z3) and to an input ZSI - IN CR (Z4) or GF (Z5)

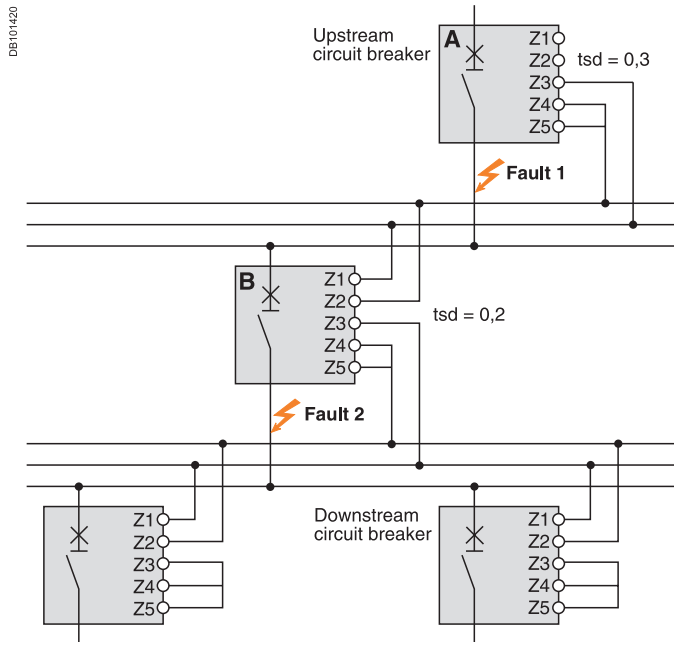

DB101420



# Additional characteristics





---

<i>Functions and characteristics</i>	<b>A-1</b>
<i>Installation recommendations</i>	<b>B-1</b>
<i>Dimensions and connection</i>	<b>C-1</b>
<i>Electrical diagrams</i>	<b>D-1</b>
<b>Tripping curves</b>	<b>E-2</b>
<i>Catalogue numbers and order form</i>	<b>F-1</b>



# Tripping curves

## ET2.0 Trip System

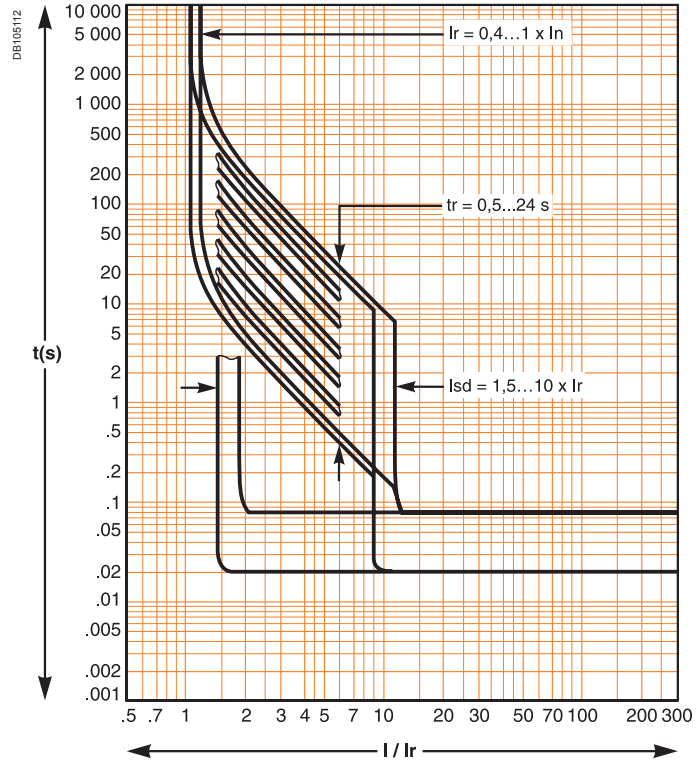

## ET6G Trip System

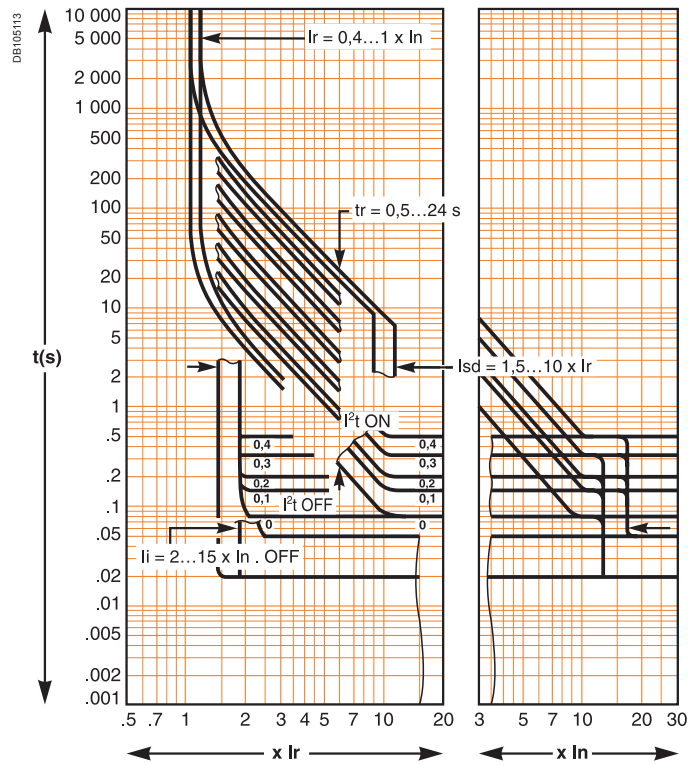



### Earth fault protection (ET6G Trip System)

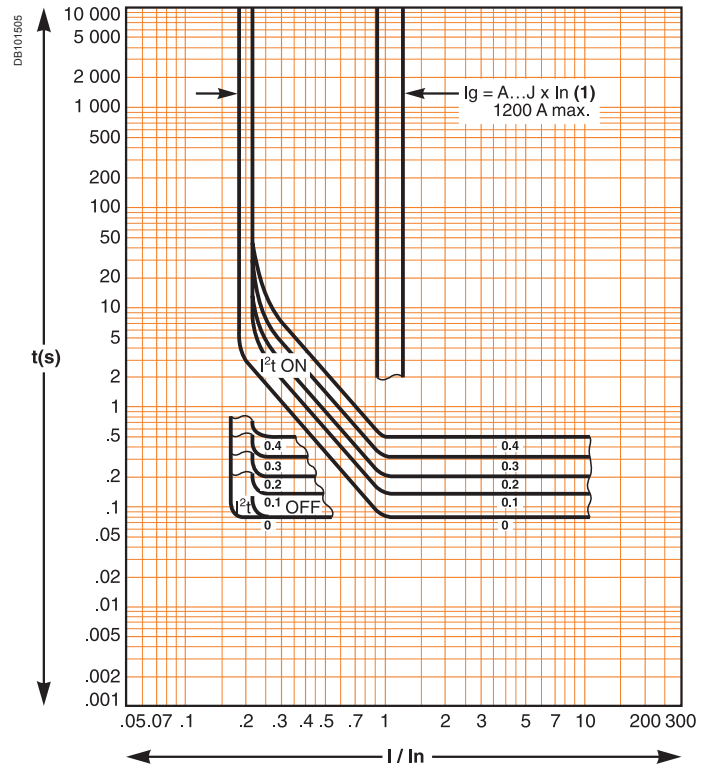

(1)

$I_g = I_n \times \dots$	A	B	C	D	E	F	G	H	J
$I_n \leq 400 \text{ A}$	0.3	0.3	0.4	0.5	0.6	0.7	0.8	0.9	1
$400 \text{ A} < I_n \leq 1000 \text{ A}$	0.2	0.3	0.4	0.5	0.6	0.7	0.8	0.9	1
$I_n \geq 1250 \text{ A}$	500	640	720	800	880	960	1040	1120	1200

# Catalogue numbers and order form





# Catalogue numbers and order form

---

<i>Functions and characteristics</i>	<b>A-1</b>
<i>Installation recommendations</i>	<b>B-1</b>
<i>Dimensions and connection</i>	<b>C-1</b>
<i>Electrical diagrams</i>	<b>D-1</b>
<i>Tripping curves</i>	<b>E-2</b>
<b>Nomenclature</b>	<b>F-2</b>
<hr/>	
<b>EasyPact SPS 800 to 1600A</b>	<b>F-3</b>
EasyPact SPS fixed	F-3
EasyPact SPS withdrawable	F-4
<hr/>	
<b>EasyPact SPS</b>	<b>F-5</b>
Connection	F-5
ET Trip System & accessories	F-6
Remote operation	F-7
Chassis locking and accessories	F-9
Clusters	F-10
Circuit breaker locking and accessories	F-11
Mechanical interlocking for source changeover	F-12
Indication contacts	F-13
<hr/>	
<b>Order form</b>	<b>F-15</b>

Range	Current rating	Type	Pole	Operating mechanism	Installation	Protection No.	Type
EasyPact SPS (from 800 to 1600A) $I_{cs} = 100\%I_{cu} = 50kA$ , $I_{cw} (1 \text{ sec}) = 42kA$ for circuit breaker & 36kA for switch-disconnector							
SPS	08 10 12 16	F	3P 4P	M E	F W	2 6 0	B L D
3	2	1	2	1	1	1	1
							<b>12 digits</b>
							<b>Type</b>
							B Basic protection without display and LED indication
							L Basic protection without display but with LED indication
							<b>Protections No.</b>
							2 LI protection
							6 LSIG protection
							0 No protection for switch disconnector
					<b>Type of installation</b>		
					F Fixed		
					W Withdrawable/drawout		
				<b>Operating mechanism</b>			
				M Manual type ACB/SD			
				E Electrical type with MCH + XF + MX			
			<b>Number of poles</b>				
			3P 3 Poles				
			4P 4 Poles				
		<b>Type based on breaking capacity</b>					
		F Circuit breaker $I_{cs} = 100\%$ , $I_{cu} = 50kA$ , $I_{cw} (1 \text{ sec}) = 42kA$					
		Switch-disconnector $I_{cm} = 75kA$ , $I_{cw} (1 \text{ sec}) = 36kA$					
		<b>Current rating</b>					
		08 800A					
		10 1000A					
		12 1250A					
		16 1600A					

Example 1

SPS12F3PMW2B

SPS	12	F	3P	M	W	2	B
EasyPact SPS	1250A	50kA	3 Pole	Manual type	Withdrawable type	LI protection	Basic trip unit without any Indication

### EasyPact SPS fixed type with ET trip unit

CDB50062

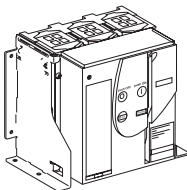

		3P		4P	
		ET2.0	ET6G	ET2.0	ET6G
Manual	800A	SPS08F3PMF2B	SPS08F3PMF6L	SPS08F4PMF2B	SPS08F4PMF6L
	1000A	SPS10F3PMF2B	SPS10F3PMF6L	SPS10F4PMF2B	SPS10F4PMF6L
	1250A	SPS12F3PMF2B	SPS12F3PMF6L	SPS12F4PMF2B	SPS12F4PMF6L
	1600A	SPS16F3PMF2B	SPS16F3PMF6L	SPS16F4PMF2B	SPS16F4PMF6L
Electrical <sup>(1)</sup>	800A	SPS08F3PEF2B	SPS08F3PEF6L	SPS08F4PEF2B	SPS08F4PEF6L
	1000A	SPS10F3PEF2B	SPS10F3PEF6L	SPS10F4PEF2B	SPS10F4PEF6L
	1250A	SPS12F3PEF2B	SPS12F3PEF6L	SPS12F4PEF2B	SPS12F4PEF6L
	1600A	SPS16F3PEF2B	SPS16F3PEF6L	SPS16F4PEF2B	SPS16F4PEF6L

### EasyPact SPS fixed type Switch Disconnecter

CDB50062

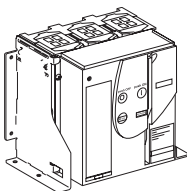

		3P	4P
Manual	800A	SPS08F3PMF0D	SPS08F4PMF0D
	1000A	SPS10F3PMF0D	SPS10F4PMF0D
	1250A	SPS12F3PMF0D	SPS12F4PMF0D
	1600A	SPS16F3PMF0D	SPS16F4PMF0D
Electrical <sup>(1)</sup>	800A	SPS08F3PEF0D	SPS08F4PEF0D
	1000A	SPS10F3PEF0D	SPS10F4PEF0D
	1250A	SPS12F3PEF0D	SPS12F4PEF0D
	1600A	SPS16F3PEF0D	SPS16F4PEF0D

<sup>(1)</sup> Supplied with spring charge motor(MCH), opening release(MX) and closing release(XF) with requested control voltage rating.

Use customer order form in page F-9 to specify coil voltages for electrical type breaker & to order optional accessories

# EasyPact SPS 800 to 1600A

## EasyPact SPS withdrawable type

### EasyPact SPS withdrawable type with ET trip unit

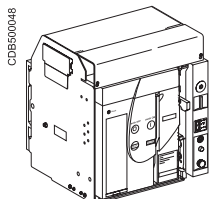

		3P		4P	
		ET2.0	ET6G	ET2.0	ET6G
Manual	800A	SPS08F3PMW2B	SPS08F3PMW6L	SPS08F4PMW2B	SPS08F4PMW6L
	1000A	SPS10F3PMW2B	SPS10F3PMW6L	SPS10F4PMW2B	SPS10F4PMW6L
	1250A	SPS12F3PMW2B	SPS12F3PMW6L	SPS12F4PMW2B	SPS12F4PMW6L
	1600A	SPS16F3PMW2B	SPS16F3PMW6L	SPS16F4PMW2B	SPS16F4PMW6L
Electrical <sup>(1)</sup>	800A	SPS08F3PEW2B	SPS08F3PEW6L	SPS08F4PEW2B	SPS08F4PEW6L
	1000A	SPS10F3PEW2B	SPS10F3PEW6L	SPS10F4PEW2B	SPS10F4PEW6L
	1250A	SPS12F3PEW2B	SPS12F3PEW6L	SPS12F4PEW2B	SPS12F4PEW6L
	1600A	SPS16F3PEW2B	SPS16F3PEW6L	SPS16F4PEW2B	SPS16F4PEW6L

### EasyPact SPS withdrawable type switch disconnecter

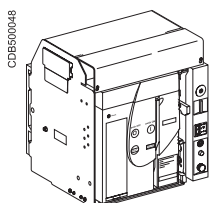

		3P	4P
Manual	800A	SPS08F3PMW0D	SPS08F4PMW0D
	1000A	SPS10F3PMW0D	SPS10F4PMW0D
	1250A	SPS12F3PMW0D	SPS12F4PMW0D
	1600A	SPS16F3PMW0D	SPS16F4PMW0D
Electrical <sup>(1)</sup>	800A	SPS08F3PEW0D	SPS08F4PEW0D
	1000A	SPS10F3PEW0D	SPS10F4PEW0D
	1250A	SPS12F3PEW0D	SPS12F4PEW0D
	1600A	SPS16F3PEW0D	SPS16F4PEW0D

<sup>(1)</sup> Supplied with spring charge motor(MCH), opening release(MX) and closing release(XF) with requested control voltage rating.  
Use customer order form in page F-9 to specify coil voltages for electrical type breaker & to order optional accessories

**Connection**

**Fixed circuit breakers**

**Rear connection (vertical mounting) / Replacement kit (3 or 4 parts)**

E6645

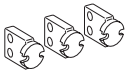

			3P	4P
800-1250 A	Vertical	MVS31111		MVS31112
1600 A	Vertical	33584		33585

Vertical mounting.

**Drawout circuit breakers**

**Rear connection (vertical mounting) / Replacement kit (3 or 4 parts)**

E6645

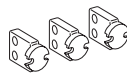

800-1250 A	Vertical	MVS31115		MVS31116
1600 A	Vertical	33586		33587

Vertical mounting.

**Connection accessories**

**Interphase barriers / Replacement kit (3 parts)**

E6628



For fixed rear-connected circuit breaker	33648	33648
For drawout rear-connected circuit breaker	33768	33768

**Spreaders (Spare/ replacement kit 800-1600A)**

For fixed and drawout rear-connected circuit breakers

MVS31109	MVS31110
----------	----------

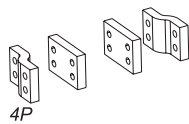
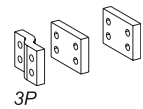

# ET Trip System & accessories

## ET trip units & accessories

### Trip units

CDB500057

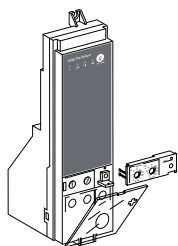

ET2.0 protection relay	MVS15514
ET6G protection relay	67479

### Battery + cover

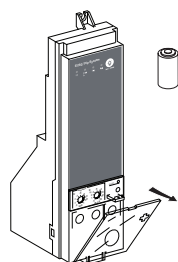

Battery (1 part)	For Micrologic 6G	33593
Cover (1 part)		33592

### External sensors

#### External sensor for earth-fault protection (TCE) / 1 part

E46671

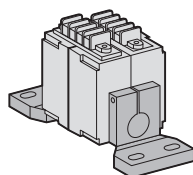

Sensor rating	400/1600 A	33576
---------------	------------	-------

### Test equipments / 1 Part

CDB500038

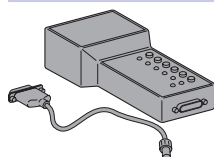

Hand held test kit (HHTK)	33594
---------------------------	-------

### Remote operation

#### Gear motor

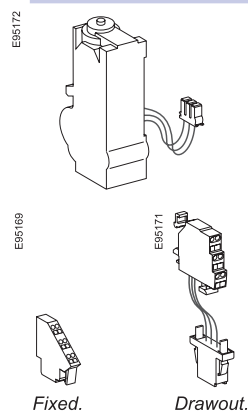

#### MCH (1 part)

AC 50/60 Hz	48 V	33186
	100/130 V	33176
	200/240 V	33177
	277/415 V	33179
	440/480 V	33179
	+resistor	33193
DC	24/30 V	33185
	48/60 V	33186
	100/125 V	33187
	200/250 V	33188
Terminal block (1 part)	For fixed circuit breaker	47074
	For drawout circuit breaker	33098

#### Closing release (XF)

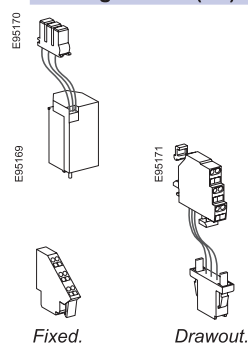

#### Standard coil (1 part)

AC 50/60 Hz	24/30 V DC, 24 V AC	33659
	48/60 V DC, 48 V AC	33660
	100/130 V AC/DC	MVS15511
	200/250 V AC/DC	MVS15512
	380/480 V AC	MVS15513
DC		
Terminal block (1 part)	For fixed circuit breaker	47074
	For drawout circuit breaker	33098

#### Opening release (MX)

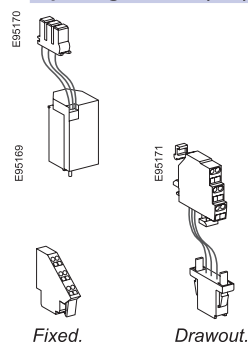

#### Standard coil (1 part)

AC 50/60 Hz	24/30 V DC, 24 V AC	33659
	48/60 V DC, 48 V AC	33660
	100/130 V AC/DC	33661
	200/250 V AC/DC	33662
	380/480 V AC	33664
DC		
Terminal block (1 part)	For fixed circuit breaker	47074
	For drawout circuit breaker	33098



## Remote operation

### Undervoltage release MN

E85170

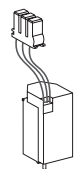

#### Undervoltage release (1 part)

AC 50/60 Hz	24/30 V DC, 24 V AC	33668
DC	48/60 V DC, 48 V AC	33669
	100/130 V AC/DC	33670
	200/250 V AC/DC	33671
	380/480 V AC	33673
Terminal block (1 part)	For fixed circuit breaker	47074
	For drawout circuit breaker	33098

E85169



Fixed.

E85171

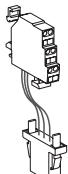

Drawout.

### MN delay unit

E46894

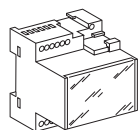

#### MN delay unit (1 part)

		R (non-adjustable)	Rr (adjustable)
AC 50/60 Hz	48/60 V AC/DC		33680
DC	100/130 V AC/DC	33684	33681
	200/250 V AC/DC	33685	33682
	380/480 V AC/DC		33683





### Chassis locking

#### "Disconnected" position locking

DB117108.eps

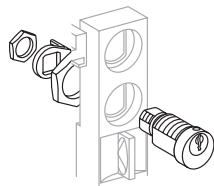

##### By padlocks

VCPO

Standard

##### By Profalux keylocks

Profalux

1 lock with 1 key + adaptation kit

64909

2 locks 1 key + adaptation kit

61910

##### By Ronis keylocks

Ronis

1 lock with 1 key + adaptation kit

64912

2 locks 1 key + adaptation kit

64913

#### Door interlock (1 part)

DB117066.eps

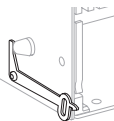

Right or Left-hand side of chassis (VPECD or VPECG)

33172

### Chassis accessories

#### Auxiliary terminal shield (CB)

DB117104.eps

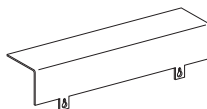

Terminal shield

3P

33763

4P

33764

#### Safety shutters + locking / 1part

DB117103.eps

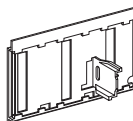

Safety shutters (VO)

3P

33765

4P

33766

*Note: The locking of safty shutters is integrated*



# Clusters

## Clusters

E95536

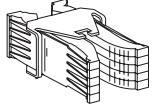

1 disconnecting contact cluster for chassis (see table below) (part 1)

64906

**Table : number of clusters required for the different chassis models**

Chassis rating (A)	EasyPact SPS	
	3P	4P
800	6	8
1000	6	8
1250	6	8
1600	12	16

## Racking handle

E95561

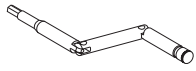

Racking handle

47098



### Circuit breaker locking

#### Pushbutton locking device / 1 part

E46666

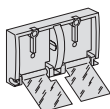

By padlocks

33897

#### OFF position locking / 1 part

E46725

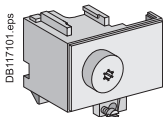

##### By Profalux keylocks

Profalux

Profalux 1 lock+ 1 key (without adaptation kit)

42888

Profalux 2 locks + 1 key (without adaptation kit)

42878

Adaptation kit (without key locks)

MVS31117

##### By Ronis keylocks

Ronis

Ronis 1 lock+ 1 key (without adaptation kit)

41940

Ronis 2 locks + 1 key (without adaptation kit)

41950

Adaptation kit (without key locks)

MVS31113

#### Escutcheon and accessories / 1 part

CDB500061

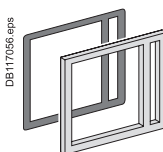

Escutcheon

E46669



Cover

E46670

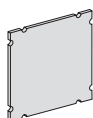

Blanking plate

	Fixed	Drawout
Escutcheon	33718	33857
Transparent cover (IP 54)	-	33859
Escutcheon blanking plate	-	33858

#### Front cover (3P / 4P) / 1 part

CDB500068

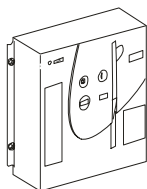

Front cover

MVS31114

#### Spring charging handle / 1 part

E66536



Spring charging handle

47092

#### Arc chute for EasyPact SPS / 1 part

CDB500069

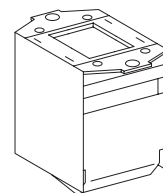

	3P	4P
Type F	3 x 47095	4 x 47095



# Mechanical interlocking for source changeover

## Mechanical interlocking for source changeover

### Interlocking of 2 devices using cables <sup>(1)</sup>

CDBE600053

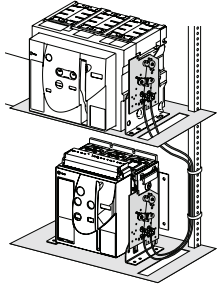

Choose 2 adaptation sets (1 for each device + 1 set of cables)

1 adaptation fixture for EasyPact SPS fixed devices	33200
1 adaptation fixture for EasyPact SPS drawout devices	33201
1 set of 2 cables	33209

**(1)** Can be used with any combination of SPS or MVS, fixed or drawout devices.



**Indication contacts**

**ON/OFF indication contacts (OF) / 1 part**

DB402837.eps

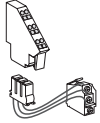

Changeover contacts (6 A - 240 V)	47076
Wiring	
For fixed circuit breaker	47074
For drawout circuit breaker	33098

**"Ready to close" contact (1 max.) / 1 part**

DB402876.eps

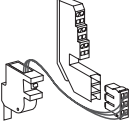

1 changeover contact (5 A - 240 V)	PF
Wiring	
For fixed circuit breaker	47074
For drawout circuit breaker	33098

**Carriage switches (connected / disconnected / test position) / 1 part**

DB402916.eps

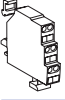

<b>Changeover contacts (6 A - 240 V)</b>	
1 connected position contact (1 max.)	33170
1 test position contact (1 max.)	33170
1 disconnected position contact (1 max.)	33170

**Auxiliary terminals for chassis alone**

DB404308.eps

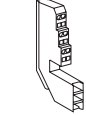

3 wire terminal (1 part), terminal block (1 part)	33098
Jumpers (10 parts)	47900



## Notes

---



## EasyPact SPS

### Circuit breaker and Switch-disconnectors Customer Order form

Order ref no:

Date:

Product ref no:

To indicate your choices, check the applicable square boxes

And enter the appropriate information in the rectangles

**Circuit breaker or switch-disconnector** Quantity

Rating	<b>A</b>	<input type="text"/>
Circuit breaker	<b>F</b>	<input type="text"/>
Switch Disconnector	<b>FA</b>	<input type="text"/>
Number of poles	<b>3 or 4</b>	<input type="text"/>
Type of equipment	Fixed	<input type="text"/>
	Draw out with chassis	<input type="text"/>
Operating Mechanism	<b>Manual Operated</b>	<input type="text"/>
	<b>Electrical Operated</b>	<input type="text"/>
<b>MCH</b> - Gear motor		V <input type="text"/>
<b>XF</b> - Closing coil		V <input type="text"/>
<b>MX</b> - Shunt/Opening voltage release		V <input type="text"/>

**ET Range of Trip System**

**ET- Without display** 2.0  6G

**LR** - Long-time rating plug **Standard** 0.4 to 1 lr

**Connection**

**Vertical spreaders**

Optional for 800 & 1000A Top  Bottom

Must for 1250 & 1600A **Standard**

*Trip System functions:*  
 2.0 : Basic protection (long time + inst.)  
 6G : Selective + earth-fault protection  
 (long time + short time + inst. + earth-fault)

**Indication contacts**

<b>OF - ON/OFF indication contacts</b>		
<b>Standard</b>	2 OF Contacts	6 A-240/380V AC
<b>Additional</b>	1 OF Contact	6 A-240/380V AC
	2 OF Contacts	6 A-240/380V AC

<b>SDE - "fault-trip" indication contact</b>		
<b>Standard</b>	1 SDE	5A-240/380V AC

**Optional**

<b>Carriage switches</b>		
		8 A-240/380V AC
<b>CE</b> - "Connected" position	Max. 1	qty <input type="text"/>
<b>CT</b> - "Test" position	Max. 1	qty <input type="text"/>
<b>CD</b> - "Disconnected" position	Max. 1	qty <input type="text"/>

<b>Remote tripping</b>		
	<b>MN</b> - Under voltage release	V <input type="text"/>
	<b>R</b> - Delay unit (fixed time delay)	0.25s <input type="text"/>
	<b>Rr</b> - Adjustable delay unit	0.5s.....3s <input type="text"/>

<b>TCE</b> - External sensor (NCT) for neutral of 3 Phase-4 Wire systems	400/1600 A	<input type="text"/>
<b>PF</b> - "Ready to close" contact	5A-240/380V	<input type="text"/>

**Locks**

**VBP** - ON/OFF pushbutton locking (by transparent cover using padlock)

<b>VSP0</b> - Device locking in OFF position by key lock (Only one key lock per ACB possible)				
	Key lock kit (w/o key lock)	Profalux	<input type="text"/>	Ronis
	1 key lock	Profalux	<input type="text"/>	Ronis
	2 identical key locks, 1 key	Profalux	<input type="text"/>	Ronis

**Chassis locking in "Disconnected" position:**

<b>VSPD</b> - by key locks	Key lock kit (w/o key lock)	Profalux	<input type="text"/>	Ronis
	1 key lock	Profalux	<input type="text"/>	Ronis
	2 identical key locks, 1 key	Profalux	<input type="text"/>	Ronis

<b>Door Interlock - VPEC</b>	On left-hand side of chassis (LH)	<input type="text"/>
	On right-hand side of chassis (RH)	<input type="text"/>

**Accessories**

<b>VO</b> - Safety shutters on chassis	<b>Standard</b>	<input type="text"/>
<b>CDP</b> - Escutcheon	<b>Standard</b>	<input type="text"/>
<b>CP</b> - Transparent cover for escutcheon		<input type="text"/>
<b>OP</b> - Blanking plate for escutcheon		<input type="text"/>
<b>CB</b> - Auxiliary terminal shield fitted on chassis		<input type="text"/>
<b>EIP</b> - Interphase barriers		<input type="text"/>
<b>HHTK</b> - Hand held test kit		<input type="text"/>

**Notes:**  
 Customer can provide the reference no. of the product for the listed references. Kindly refer to product catalogue for list of references.  
 All breakers will be provided with 2 OF (2 c/o contacts), 1 SDE (trip contact), Escutcheon (Panel sealing frame) as standard.  
 All draw-out type devices will be supplied with Chassis & safety shutter.  
 For Electrical operated devices, indicate the voltage ratings of MCH, XF & MX  
 Refer to product catalogue for available voltage ratings of MCH/XF/MX/MN.  
 All SPS products are supplied with vertical type customer connecting terminals.



**Schneider Electric Industries SAS**

35, rue Joseph Monier  
CS 30323  
F- 92506 Rueil Malmaison Cedex

RCS Nanterre 954 503 439  
Capital social 896 313 776 €  
[www.schneider-electric.com](http://www.schneider-electric.com)

*As standards, specifications and designs change from time to time, please ask for confirmation of the information given in this publication.*



*This document has been printed on ecological paper*

*Design: Schneider Electric  
Photos: Schneider Electric  
Printed:*