

masibus



Condition Monitoring Products & Solutions

**VIBRATION SENSORS | VIBRATION TRANSMITTERS | VIBRATION SWITCH |
VIBRATION METERS | VIBRATION MONITORING SYSTEM**

www.masibus.com

Online Vibration Monitoring Sensor

VibraSens - Vibration Sensors

- With Vibrasens, Masibus is committed to supply the highest quality line of various kinds of Vibration sensors in the world at the best prices.

Vibrasens Product Ranges

Vibrasens offers a comprehensive selection of [®]ICP industrial piezoelectric accelerometers and vibration sensors in a variety of industrial packages

Speciality

- Accelerometer, Velocity sensor, 4-20mA sensor
- General purpose, premium
- General purpose, economy
- Low frequency
- Multi output with Temperature
- 4-20mA Loop Power sensor
- High temperature
- High frequency

Key Differentiators

- 10 Year MTBF
- IP68 protection
- Dual Case isolation
- Annual Shear design
- [®]ICP transmission mode
- EMC emission (EN 50081-1, EN 50081-2)
- EMC immunity (EN 50082-1, EN 50082-2)
- Material - AISI 316L, DIN 1.4404 (Stainless steel)
- Compliance with API670



Accelerometer

Features

- 10, 100, 500 mV/g version available
- 55 °C to 120 °C (-67 °F to 248 °F)
- [®]ICP transmission mode
- Annular shear mode
- Dual case isolation with Faraday shield
- IP67 with associated cable
- Complies with API 670 requirements (A=6 only)

Benefits

- Continuous Machine Health Monitoring
- Easy to connect and install
- Safety for operator for taking reading
- Reliable reading of inaccessible areas
- Annular shear mode is less susceptible to transverse vibrations and better immune to saturation at high frequency
- Exceptional bias voltage stability at elevated temperatures

4-20mA Loop Powered Sensor

4-20 mA loop powered industrial accelerometer uses the industry standard 4-20mA Loop that interfaces directly with PLC, DCS and 4-20mA monitor

Features

- Economy model
- Reverse wiring and ESD protection
- Output 4-20 mA in Loop
- Transverse response sensitivity (20 Hz, 5g) < 5%
- Voltage source: 10 to 30 VDC

Benefits

- Large choice of output (velocity, acceleration, RMS, equivalent Peak) and frequency range helps to fit almost every customer requirements
- Continuous Machine Health Monitoring
- Easy to connect and install
- Safety for operator to take reading
- Reliable reading of inaccessible areas



Technicad - Proximity Sensor (MDS10/MDT10)

The non-contacting displacement probe transducer systems are gap to voltage devices that measure static as well as dynamic distances between the probe tip and the observed target.

- Nominal measuring range : 2mm, 2.5mm, 3.0mm, 3.5mm, 4.0mm
- Frequency Response : 0 to 10KHz
- Nominal Output Voltage Range : -4V to -20V
- Housing Material : Probe-robust stainless steel, Transducer-aluminum alloy
- The probe tip is constructed of polyphenylene sulfide, a high performance plastic, impervious to oil, water and many different chemical liquids.
- The most common use is for shaft position and relative vibration measurement on rotating machinery
- The transducer detects in the return signal the strength loss for the eddy-currents generated in the observed surface and conditions the signal for linear voltage output.
- The probe-transducer system indicates the dynamic motion of the shaft relative to the bearing



Accessories

Sensor Cable

Features

- Vibration Sensor Cable assembly with suitable connector
- Protection Class IP67
- Temperature Range -25 °C to +90 °C
- M12 Over Molded
- Available : SS Armor, Teflon cable

Benefits

- Low noise
- Twisted Shielded to protect against EM
- Molded cable for better connection
- Bakelite connector for harsh environment
- SS Armor for better protection



Mounting Pad

Features

- Made of SS
- M6 Threading
- Suitable for Vibration sensor mounting

Benefits

- Easy mounting of Vibration Sensor
- Provide good surface finish required for mounting of vibration sensor
- Proper threading for better mounting of sensor



Online Vibration Monitoring Products

Vibration Transmitter (VT7S10)

Vibration Transmitter VT7S10 is a strategic tool for predictive maintenance. It provides on-line vibration monitoring and provides easy communication to data acquisition system where vibration can be displayed, trended and alarm can be generated.

Features

- Velocity range: 0-12.5, 0-25, 0-50 mm/s (factory selectable)
- Vibration is measured in terms of R.M.S & peak to peak
- Range can be re-calibrated

Benefits

- Loop powered
- Easy to connect and install
- Buffer output for analysis
- Re-calibration



Dual Channel Vibration Transmitter (VT7S12)

Micro-controller based Dual Channel Vibration Transmitter VT7S12 with Dual Retransmission Output is a low cost high performance two channel vibration alarm monitor in a modular format ideally suited for protection of rotating machinery against costly breakdown, including motors, fans, pumps etc.

Features

- Input Type: Accelerometer
- Dynamic buffered signal output for analysis
- Output - 2 x 4-20 mA proportional to vibration level (1 per channel)
- RS485 communication - optional
- Small Compact size DIN rail mounted

Benefits

- Field programmable Range for Acceleration, Velocity or Displacement
- Scrolling display
- Front key configuration
- Different set points
- Time delay for relays



Vibration Switch (VSW-150/VSW-160)

Vibration Switch is a strategic tool for protection of rotating machines. It measures online vibration and provides relay output for operator alarm or machine trip purpose. Once the alarm is generated, machine data can be analyzed for the root cause of increased vibration. Vibration Switch makes on-line monitoring cost-effective.

Features of VSW-150

- Three in One (Transmitter, Indicator and Switch)
- ABS IP20 protection
- Remote sensor mounting
- Bright 3½ LED display
- Easy configuration from front keys
- Relay output with Status Indicator and Power Indication
- Vibration Range available up to 50 mm/s
- Precise isolated analog output

Features of VSW-160

- Three in One (Transmitter, Indicator and Switch)
- IP66, FLP Gas group I, IIA & IIB protection
- Remote sensor or inbuilt sensor option.
- Bright 3½ LED display
- Touch Sensitive Keys for Operation
- Relay output with Status Indicator and Power Indication
- Vibration Range available up to 100 mm/s
- Precise isolated analog output (optional)

Benefits

- Good replacement of Mechanical type Vibration switches
- Local digital indication for vibration measurement
- Protects machines from break down



RPM Monitor (409-S RPM)

409-S Monitor is versatile microcontroller based RPM indicator. 409-S is designed for speed measurement of industrial equipment using proximity sensor. It provides non-contact measurement of rotor speed. Retransmission analog output which can be connected to plant RTU/PLC/ DCS Systems.

Features

- Various RPM range available
- Relay & analog output
- LED display and Easy configuration from front keys
- Excellent long term Stability

Benefits

- Cost-effective online speed monitoring
- Measures online RPM and provides relay output for operator alarm or machine trip purpose



Vibration Monitor - 4 channel (VMS-4S)

VMS-4S vibration monitor accepts the vibration signal from an accelerometer and converts it to a 4-20mA output. It also provides buffered output of the raw signal from the accelerometer for vibration analysis. The output 4-20 mA can be interfaced with PLC or DCS system, which in turn can continuously monitor the condition of machine.

Features

- Micro-controller based 4 channel monitoring
- RS485 Output for communication
- Parameter: Displacement, Velocity, Acceleration
- Buffer Output

Benefits

- Fully configurable & programmable by front keypad
- Scrolling display
- Different set points
- Relay output for danger and alarms for protection of machine
- Time delay for relays



Portable Tools for Analysis

Vibration Meter (VM-908)

VM-908 Vibration meter is a portable device used for the measurement of the machine vibration. It measures the vibration to which it is exposed. It provides essential periodic monitoring of fan, pump, motor and other industrial machines.

Features

- 3½ LCD digital Display
- Vibration meter provides off-line monitoring with various parameters like Displacement, Velocity and Acceleration
- Battery: 9V6F22, 25 hours of continuous operation
Vibration is measured in terms of R.M.S. and peak

Benefits

- VM-908 is a very handy tool for the technician
- VM-908 is a very compact device easily can be put in to your pocket



VMI-AB - Vibration Meter Viber - A⁺™

Features

- VIBER - A⁺™ is designed to be very easy to handle, with high reliability and quality to a low cost!
- Designed for service technicians, operators and overall simple tests, like fault in machines
- Measures high vibration levels or high bearing condition value
- 7 segment Red LED display



VMI-AB - Vibration Meter Viber-X3™

Features

- Accurate measurements for 4 selectable frequency ranges
- Fast and easy fault analysis screen displaying the five highest peaks with amplitude and frequency one by one
- Headphone set with volume control and high pass filter for bearing noise detection
- Balancing according 3-point method
- Measurement units selectable by the user in g, m/s², mm/sec, inch/sec, mills, μm (RMS, Peak or Peak-Peak)
- Bearing Condition measurements
- Built-in infrared temperature sensor, units in °C or °F
- Bar indicator shows measurement stability
- Large dynamic range of the vibration signal (up to 50 g)
- Clear vibration, temperature and danger alarms by red and yellow color LED's
- Dust and waterproof, for rough use (IP65)



VMI-AB - Vibration Meter X-Viber

X-Viber is a low-cost route data collector. Data collection and trend analysis introduces a great many possibilities to save money

Features

- Selectable Measuring unit, Frequency range
- Options of Data Logging
- Single plane balancing with the 3-point/ Vector method
- Amplitude and phase measurements
- Higher availability, low power consumption, avoids catastrophic failure

Benefits

- Total Vibration level
- Bearing Condition Value
- FFT analysis
- Envelope analysis
- Speed Measurements
- Temperature measurements



VMI-AB - Vibration Measurement Instrument VIBER X5™

Features

- Provides a complete package for predictive condition maintenance
- One - and two - plane balancing
- Coast-down/up, Orbit analysis, bearing conditions
- Amplitude and Phase, Envelope Spectra
- Datalogger for long term recording
- Route based data collection
- Motor current signature analysis - optional
- No additional software upgrade cost, No annual service fee
- Roughed and tight (IP65)



Portable Tools for Balancing

Hofmann - Vibrometer MC1100

Features

- ▣ Portable and ready to operate
- ▣ Checking machine vibrations
- ▣ Evaluation of the condition of rolling bearings
- ▣ Checking rotational speed
- ▣ Machine rotating at low and high speed can be well assessed
- ▣ Measuring temperature (Option)
- ▣ Check of belt tension (Option)
- ▣ Identification of critical operational areas
- ▣ Early detection of failures



Hofmann - Mini Balancer MI2100

Features

- ▣ Field balancing and checking vibrations with one instrument
- ▣ Single or dual plane field balancing
- ▣ Easy to understand and reliable user menu
- ▣ Portable and ready to operate
- ▣ Measuring and balancing protocol
- ▣ Measuring rotational speed
- ▣ Excellent cost/performance ratio



Hofmann - VibroLyzer VL 8000

Features

- ▣ Vibration analysis, Machine Diagnostics, Field Balancing
- ▣ Very large color LCD
- ▣ Analyzing frequencies of a vibration (FFT)
- ▣ Evaluating resonance frequencies and transfer functions
- ▣ Observing and recording vibration data
- ▣ Detecting machine damage
- ▣ Tracking analysis, Order analysis
- ▣ Balancing in one or two planes
- ▣ PC Software



Hofmann - Online Balancing System

- ▣ The active balancing system automatically compensates unbalance during the operation of a machine
- ▣ Time savings through fast electromagnetic drive and adaptive balancing methods
- ▣ Balancing during machine operation
- ▣ Increased product quality and machine availability
- ▣ Suitable for very high speeds
- ▣ Permanent unbalance monitoring
- ▣ Unbalance correction within short time
- ▣ Neutral position for manual prebalancing
- ▣ Windows operating and visualization software
- ▣ Field balancing software
- ▣ Compensation of operational unbalances
- ▣ Balancing of rotors, grinding wheels, grinding spindles

Process Industry

- ▣ Fans, Compressors - correction of unbalance due to trash buildup, dirt accumulation
- ▣ Paper rolls - Compensation of unbalance due to thermal distortion, condensate build-up
- ▣ Pumps - compensation of hydraulic unbalance

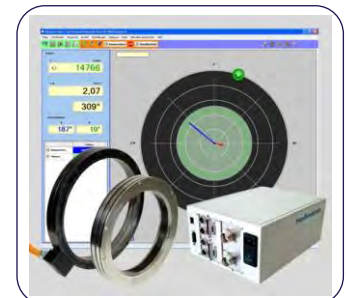

Online Vibration Monitoring Systems

Periodic monitoring provides a good solution for Balance of Plant machinery. This is because of the large number of points to be monitored each month. Too many to have continuous monitoring on all of them! Still, online vibration monitoring is required for some of measurement points because of following reasons and benefits

- ▣ Machines with higher than normal maintenance (Faster deterioration of machine health)
- ▣ Better operating condition visibility
- ▣ Personnel safety (must climb to reach measurement points)
- ▣ Hard to get to machines (like cooling towers)
- ▣ Increased workloads for personnel

Masibus offers following VMS solution for various applications.

Cooling Tower Fan Monitoring

- ▣ Access to gear box is difficult in cooling tower fan
- ▣ Sensor to be mounted on bearing support part on motor and gear
- ▣ Bearing condition, casing vibration and fan vibration can be measured online
- ▣ Detection of potential problems like fan imbalance/ broken fan blade can be detected at early stages
- ▣ Low cost to justify installation

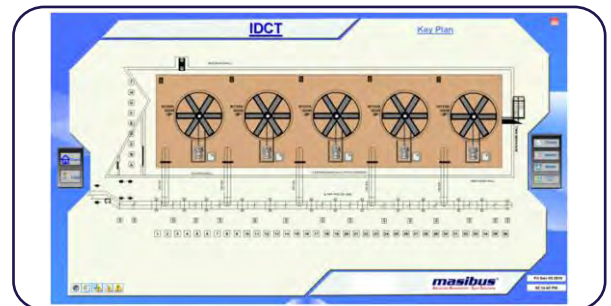

ID/FD Fan Monitoring

Elements like Seal failure, bearing failure, poor lubrication, coupling problem misalignment and fan/blower Imbalance can be monitored using a online Vibration Monitoring system

- ▣ Frequency of failures will reduce by online Vibration Monitoring
- ▣ Alarm level can be set as per the criticality
- ▣ Measurements can be acceleration or velocity

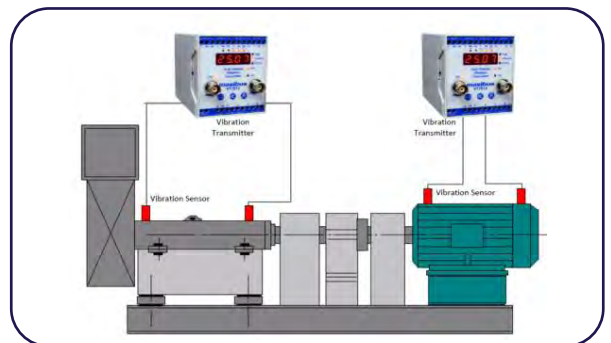

Crusher Monitoring

The monitoring system of the crusher provides automatic and continuous monitoring of the vibration that emanate from the crusher during every idle state or running state of operation of the crusher.

- ▣ Monitors healthiness of the Rotational Machinery
- ▣ Acknowledge abnormalities
- ▣ Safe guard Machine
- ▣ Database for Analysis

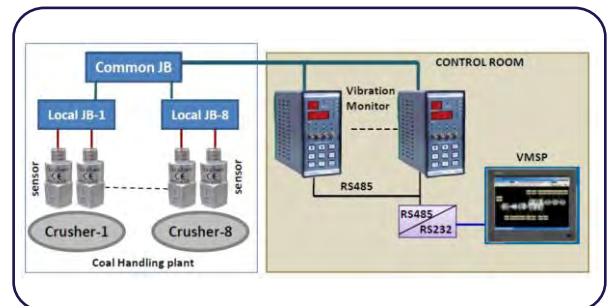

Thrust Monitoring

- ▣ Thrust Monitoring system is intended for shaft axial (Thrust position) measurement in Turbines, pumps, compressors and other machines
- ▣ Thrust Monitoring system monitors machine trends and alarms in case of excessive axial movement to avoid serious problems
- ▣ The non-contacting displacement probe transmitter system is a gap to dc current device that measure static distance between the probe tip and the observed target

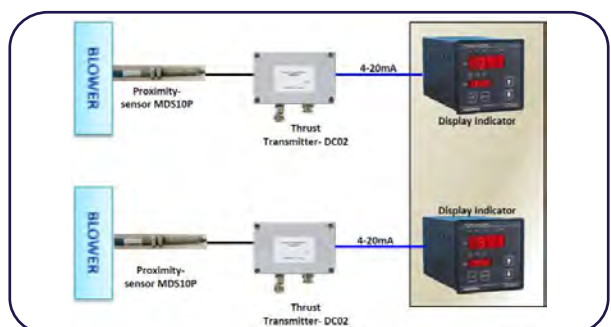

Machine Protection And Monitoring System - TNC 2000

The TNC2000 machine protection and condition monitoring system is based on the measurements of shaft axial position in thrust bearing, shaft differential thermal expansion, case absolute thermal expansion; bearing case absolute vibration, shaft relative vibration; valve position and phase angle/rotating speed.

Features

- A system as whole unit is developed according to standards API670, ISO 10817, ISO2954, ISO7919, ISO10816 and other
- TNC 2000 system is composed of a wide range of different elements
 - Sensors and Transducers
 - Electronic modules – Monitors, Power supply, Local multi-channel display, Data acquisition unit
 - Mechanical casings – 19" rack, 19" cabinet
 - Data acquisition and diagnostics software
- Provides continuous operational supervision of rotating machinery such as turbosets, compressors, blowers, exhaust fans, pumps, gears and others.



Condition Monitoring Services

Vibration Analysis And Diagnostic Services

Masibus provides vibration-based diagnostics services to industries so as to cater to their specific requirements. Experienced personnel and instrumentation are at hand to render Machinery Vibration Monitoring & Analysis Services.

- Vibration monitoring provides predictive maintenance of the rotating machines in industries
- Minimize the failure of machines before time and thus prevents the costly failures
- Dynamic balancing- Single/Dual plane
- Analysis and Identification of Fault/ Root Cause
- Value added services at affordable rates

Thermography Services

Infrared Thermography is used to detect hotspots, hidden problems; excess heat so that problems can be found and maintenance personnel can take appropriate action to correct the problem avoiding electrical failures thus increases the safety. Masibus provides Thermography services to carry out the survey of electrical installation (MCC & PCC panel, switchgears, Motor junction box terminal, switchyards etc) and mechanical equipment (compressor, pipe leakage, refractories etc). IR thermography provides a quick and safe way of detecting problems in many different situations

Vibration Certification Exam

Masibus is the accredited representative of The Vibration Institute in India. The Vibration Institute's Certification Program follows the International Standards Organization standard, ISO 18436, Condition Monitoring and Diagnostics of Machines. The Vibration Institute's Certification Program for Vibration Analyst was developed by and is governed by a committee representing various industries and is used worldwide. Category I vibration analysts are capable of performing simple machinery vibration measurements involving single-channel condition monitoring and diagnosis. Experienced analysts may go directly to the examination for Category II.

Vibration Calibration Services For Sensors / Analyzer

Masibus provides calibration services for the vibration sensors (viz. Accelerometer, velocity and displacement) and vibration analyzers. Using the back to back calibration by substitution, reference transducers are calibrated by primary reference transducer, as per ISO 16063-11:1999.

- Sensitivity calibration
- Provide reliable information
- Traceability with NIST
- Increases confidence in measurement
- Easy access to our facility
- Option of onsite service



MASIBUS AUTOMATION AND INSTRUMENTATION PVT. LTD.

B-30, G.I.D.C. Electronics Estate, Sector-25, Gandhinagar - 382 044, Gujarat, INDIA.

Tel.: +91 79 23287275 - 79 Fax: +91 79 23287281 - 82

E-mail: sales@masibus.com Web: www.masibus.com

National Offices

Ahmedabad

Cell: +91 9662064676
E-mail: ahmedabad@masibus.com

Bengaluru

Cell: +91 9844023160
E-mail: blr@masibus.com

Bhilai

Cell: +91 9589341230
E-mail: central@masibus.com

Chennai

Cell: +91 9840483388
E-mail: chennai@masibus.com

Delhi

Cell: +91 8468932323
E-mail: delhi@masibus.com

Goa

Cell: +91 9822135796
E-mail: goa@masibus.com

Indore

Cell: +91 7869887659
E-mail: indore@masibus.com

Kolkata

Cell: +91 9903006265
E-mail: kolkata@masibus.com

Mumbai

Cell: +91 9892263577
E-mail: mumbai@masibus.com

Pune

Cell: +91 9689937234
E-mail: pune@masibus.com

International Offices

Sharjah

Cell: +971 506376546
E-mail: sharjah@masibus.com

For Sales Service, Call TOLL FREE (India only)

1-800-233-2273

1-800-ADD-CARE

Masibus Representative