

MECO®

SINCE 1962





Late. Parasmal Goliya
(Founder)



Premchand Goliya
(Chairman & Mg. Director)



Kamal P. Goliya
(CEO)

We are an ISO 9001 : 2008 certified company offering various **reliable, long - lasting and affordable instruments** since over five decades. Our team of skilled and trained personnel are equipped with complete in-house facility for design, development and manufacturing world class products. Customer focus, product innovation and technological excellence are the prime concerns of every member at MECO.

Many products have been designed by our R & D Department (Recognized by Department of Scientific & Industrial Research, Ministry of Science & Technology, Govt. of India, New Delhi) which holds several design registrations / patents. The **Make In India** spirit is very much ignited at MECO and we use state of art electronics and mechanical infrastructure along with indigenously developed intelligent software / firmware in creating products that are ideal for the **Power, Renewable Energy, Solar and Automotive Sectors**.

Keeping pace with India's booming requirements, some of our newly introduced products are :

3 Phase TRMS Multifunction Power and Energy Meter with M.D. & T.H.D.

- POWERGUARD - TRMS for monitoring the power consumption of domestic and industrial loads.
- Its ideal for use on various types of electrical appliances like air conditioner, refrigeration, washing machine etc.

Improved design of programmable Digital A, V, W, VAR, VA and PF Meters for LT and HT Panels.

- Mini Series of Digital Panel Meter for smaller equipment / panels.

PC Interface Digital Multimeter with USB Port, 4.5 Digit Autoranging Digital Multimeter and 6000 / 6600 Count TRMS Professional Digital Multimeters are some of the new launches.

- 1200A DC / AC TRMS and 1000A AC TRMS Professional Digital Clampmeters with fully loaded features and functions.

Phase Sequence Indicator, Digital Earth Tester and Transformer Turns Ratio Meter are products that compliment the basket of an electrical engineer and technician.

- Vehicle Battery System Meter, Multifunction Automotive Meter and Digital Automotive Multimeter have been introduced to cater to the needs of the Automotive sector.

Handheld Thermal Imaging Camera and Laser Distance Meter finds application in maintenance of buildings, electrical equipment, transport industry, electronic / electrical manufacturing, archaeological study, smelting fields to name a few.

- Clamp-On TRMS Power & Energy Meter with Automatic Computation of 1 Phase and 3 Phase Parameters is useful to check motors, compressors, HVAC systems etc.



MECO has a network of over **60 Authorised Dealers / Distributors** who effectively channel the products in the entire Indian subcontinent with good penetration. Our products are exported to almost all the continents of the world through local agents and representatives.

We seek strategic alliances with companies worldwide who can either effectively market our products in their local markets or with companies who wish to channel their products in India through our marketing network.









1	1	Company Introduction
2	3	Index
4	7	Company Profile

Multifunction Meters

10	10	Multifunction Meters - Selection Guide
11	11	3 Phase Multifunction Power & Energy Meter with M.D. & T.H.D. Functions - TRMS 
12	13	3 Phase Multifunction Power & Energy Meter / Power Line Supervisor - TRMS
13	13	RS485 - RS232 Converter
14	15	3 Phase Multifunction Power & Energy Meter / Power Line Supervisor - TRMS
15	15	Power Master Software
16	16	3 Phase VAF / VIF Meter - TRMS
17	17	1 Phase Multifunction Meter - Selection Guide
18	18	1 Phase Multifunction Meter - TRMS
19	19	1 Phase Multifunction Meter - TRMS with RS 485 Communication Port
20	21	1 Phase Multifunction Appliance Meter - TRMS with RS 485 Communication Port
22	23	POWERGUARD / POWERGUARD - TRMS 



Digital Panel Meters & Modules

26	27	4 Digit Programmable Ammeter / Voltmeter - TRMS 
28	29	3½ Digit Ammeter / Voltmeter
30	30	5 Digit Voltmeter / Ammeter - TRMS (72 x 144 mm) 
31	31	5 Digit 3 Phase Watt / VAR / VA Meter - TRMS (72 x 144 mm) 
31	31	4 Digit 3 Phase Power Factor Meter - TRMS (72 x 144 mm) 
32	33	4½ Digit Ammeter / Voltmeter
34	34	3 Phase Ammeter / Voltmeter (with Built-In Selector Switch)
35	35	3 Phase Programmable Ammeter / Voltmeter - TRMS 
36	36	Double Voltmeter / Double Frequency Meter
37	37	4 & 5 Digit Frequency Meter / 4 Digit RPM Meter
38	38	Digital Power Factor Meter (with Built-In Transducer)
39	39	Digital Power Factor Meter (with Built-In Transducer) - TRMS
40	41	Digital Wattmeter / Digital Varmeter (with Built-In Transducer)
42	42	Digital Wattmeter / Digital Varmeter (with External Transducer)
43	43	3½ Digit Ammeter / Voltmeter (Mini Series) 
44	44	3½ Digit Ammeter / Voltmeter (5 VDC Aux. Supply)
45	45	3½ & 4½ Digit LCD / LED Modules - Professional Series 
46	46	3½ Digit LCD / LED Modules
47	47	Article on TRMS Meters



Power Line Transducers

50	52	Power Line Transducers - Introduction, Selection Guide and Specifications
53	53	AC Current Transducer
54	54	AC Voltage Transducer
55	55	Frequency Transducer
56	56	DC Isolation Transducer / DC - DC Converter
57	57	Active Power (Watt) & Reactive Power (Var) Transducer
58	58	Power Factor Transducer
59	59	Tap Position Transducer



Analog Panel & Switchboard Meters





62	63	Analog Panel & Switchboard Meters - Introduction
64	64	AC Moving Iron DIN Panel Ammeter & Voltmeter
65	65	DC Moving Coil DIN Panel Ammeter & Voltmeter
66	66	AC Moving Coil Rectifier Type DIN Panel Ammeter & Voltmeter
67	67	Electronic Analog W, Var, PF & Hz Meters
68	68	Rectangular AC & DC Panel Meter
69	69	Educational Desk Stand Meter
70	70	Dimension



Testing & Measuring Instruments - Digital Multimeters & Digital Clampmeters

72	73	6½ Digit 12,00,000 Count Bench Top Digital Multimeter
74	74	3¾ Digit 4,000 Count Digital Multimeter with PC Interface & Datalogging Software 
75	75	4½ Digit 20,000 Count Digital Multimeter - TRMS (Autoranging) 
76	76	3½ Digit 2,000 Count Digital Multimeter - TRMS 
76	76	3% Digit 6,600 Count Digital Multimeter - TRMS 



77	77	3% Digit 6,000 Count Digital Multimeter - TRMS 
78	78	Digital Multimeter
79	79	3½ Digit 2,000 Count Digital Multimeter (Autoranging) 
79	79	3¾ Digit 4,000 Count Digital Multimeter (Autoranging)
80	81	Digital Clampmeter (Autoranging) - 400A AC / 1000A AC
82	82	Digital Clampmeter (Autoranging) - 1000A AC
83	83	Digital Clampmeter (Auto / Manual) - 600A AC / 1000A AC TRMS 
84	84	Digital Clampmeter (Autoranging) - 600A DC / AC
85	86	Digital Clampmeter (Autoranging) - 1000A / 1200A / 2000A DC / AC TRMS 





Testing & Measuring Instruments - Others

88	88	Insulation Tester - Analog
89	89	Insulation Tester - Digital
90	90	5kV - 200GΩ Digital Insulation Tester
91	91	Phase Sequence Indicator 
92	92	Leakage Current Tester
93	93	Earth Tester - Digital 
94	96	Clamp - On Earth / Ground Resistance & Leakage Current Tester 
97	97	LCR Meter
98	98	Micro - Ohmmeter / Milli - Ohmmeter
99	99	Transformer Turns Ratio Meter 



Automotive Meter & Battery Tester

102	102	Battery Meter
103	103	Vehicle Battery System Meter 
103	103	Digital Automotive Multimeter 
104	104	Multifunction Automotive Meter 
105	105	Battery Internal Resistance (Impedence) - Introduction
106	106	Battery Capacity (Impedence) Tester for Batteries upto 500Ah
107	108	Battery Capacity (Impedence) Tester with DC Current Adaptor for Batteries upto 1200Ah







Solar Analyzers

110	111	Solar Module Analyzer (Photovoltaic I-V Curve Tester)
112	115	Solar System Analyzer (Photovoltaic I-V Curve Tester)
116	116	Solar Power Meter



Environment Testing Instruments

118	118	Infrared Thermometers 
119	119	Handheld Thermal Imaging Camera 
120	121	Environment Testing Instruments 
122	123	Electrosmog Meter - 3 Axis
124	124	Laser Distance Meter 



Power & Harmonics Analyzers

127	129	Power & Harmonics Analyzer
130	130	Energy Auditor / Electrical Appliance Tester
131	131	Power Harmonics & Leakage Tester
132	132	AC Clamp - On Power & Harmonics Tester
133	133	3Φ / 1Φ TRMS Clamp - On Power Meter for AC / DC Power Measurement
134	139	Clamp - On TRMS Power & Energy Meters 



Calibrating Equipment

142	142	Calibrating Equipment - Selection Guide
143	143	Universal Calibrator
144	144	Multifunction Calibrator
145	145	AC Multifunctional Calibrator
146	146	Multifunction Process Calibrator



Clamp - On CT's / Precision Split Core CT's / PCB Mountable CT's

148	150	Clamp - On CT's / Flexible AC Current Probe 
151	151	Split Core CT's (AAC to VAC) / (AAC to AAC)
152	152	PCB Mountable High Precision Current Transformers



Copyright and Disclaimer

The material presented in this publication is copyright protected ©2016 by M/s. MECO Instruments Pvt. Ltd., Navi Mumbai (India) and may not be reproduced in any form, by any method for any purpose without the prior written consent of M/s. MECO Instruments Pvt. Ltd., Navi Mumbai (India). In our endeavour to make better products, the specifications are subject to change. Trade Marks, Logos and References used of various organisations are hereby acknowledged.

Chairman & Managing Director

Mr Premchand Goliya

Associated with Professional Bodies / Associations

- **Former President,**
IEEMA (Indian Electrical & Electronics Manufacturers Association), Mumbai
- **Former Chairman,**
CII (Instrumentation Division), N Delhi
- **President**
AOTS Alumni Association of Western India (AAAWI)
- **Former President,**
All India Instrument Manufacturers & Dealers Association, Mumbai
- **Member,**
Instrument Experts Club, Mumbai
- **Member,**
Governing Council, Institute for Design of Electrical Measuring Instruments, Mumbai
- **Member,**
Bureau of Indian Standards,
Electrical Instruments Sectional Committee, N Delhi
- **Member,**
Engineering Export Promotion Council, N Delhi

Directors

- Mr Kamal Goliya** (Director & CEO)
- Mr Jhanwarlal Sipani** (Administration)
- Mrs Nandita Goliya** (Personnel)

Registered Office & Works

Plot No. EL-1, MIDC Electronic Zone, TTC Indl. Area,
Mahape, Navi Mumbai 400 710. (INDIA)
Tel : 0091-22-27673311-16 (Sales), 27673300 (Board)
Fax : 0091-22-27673310, 27673330
Email : info@mecoinst.com Web : www.mecoinst.com

Authorised Service Centres

Navi Mumbai and Bangalore

Year of Establishment

1962

Banker

M/s Canara Bank, Vashi Branch, The Emerald, Shop No.1- 4,
Sector 12, Vashi, Navi Mumbai - 400703 (India)
A/C : 020612, MICR Code : 400015145

MSME Registration (MICRO Enterprise)

Registration No. 27-021-11-01207 Dt. 28-11-2007

In-House R&D Unit

Recognized by Department of Scientific & Industrial Research, Ministry of Science & Technology Government of India, New Delhi

Awards and Certifications

Engineering Export Promotion Council
(Government of India)

Awards For Highest Export Of Panel Instruments
1984-85 1994-95 1995-96 1996-97



ISO 9001:2008 CERTIFICATE



2004,2005,2006 & 2007



EEPC AWARD



EIL APPROVAL

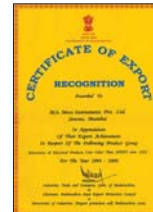

Government of Maharashtra

Award in Appreciation of Export Achievement
1999-2000



PGCIL APPROVAL

Registrations

ISO 9001 : 2008

Certificate No. IND 14.5515U/Q
Original Approval Dt. 14.12.2002 - BVQI, London

Recognised In - House R&D Unit

TU/IV-RD/1973/2010 Dt. 01.04.2011 Renewed upto 31.03.2016

Small Scale Industry / SME

270211101207 Date 28.11.2007 (EL-1, Mahape)

NSIC Registration No.

PMT : NSIC/MUM/GP/RS/M-14/MH Date 11.01.2008

VAT (Central)

27940002826C

VAT (Local)

27940002826V

Central Excise Registration No / ECC No.

AAACM2883QXM002

Range & Address

IV, CGO Complex, Belapur, Navi Mumbai - 400614

Division & Address

III, CGO Complex, Belapur, Navi Mumbai - 400614

Permanent Income Tax No. (PAN)

AAA CM 2883 Q

Company's Act

14477 Date 15.12.1969

Factory Act

Thane - 2(m)(i)/31/06/31909 Date 29.03.2006

Import Export Code Number

0388036184

Service Tax Registration No.

AAACM2883QST002

Product Profile

PANEL & SWITCHBOARD INSTRUMENTS

- Multifunction Meters
- 1 Phase & 3 Phase Power Energy Meters
- Appliance Tester / Power Guard
- VIF / VAF Meters
- Digital Panel Meters and Modules
- Power Line Transducers
- Analog Panel & Switchboard Meters
- Educational Desk Stand Meters
- Split Core / PCB Mountable CT's

TESTING & MEASURING INSTRUMENTS

- Digital Multimeters / Clampmeters
- LCR Meters / Insulation Testers
- Clamp-On Earth / Ground Resistance Testers
- Leakage Current Tester / Earth Tester
- Milli Ohm / Micro Ohm Meters
- Transformer Turns Ratio Meter
- Phase Sequence Indicator

AUTOMOTIVE METER & BATTERY TESTERS

- Multifunction Automotive Meter
- Battery Capacity Tester / Meter

ENVIRONMENT TESTING INSTRUMENTS

- Laser Distance Meter
- Thermal Imaging Camera
- Infrared Thermometers
- Air Flow Anemometer
- Lux / Sound Level Meter
- RPM Meter
- Humidity & Temperature Meter
- Electrosmog Meter

POWER & HARMONICS ANALYZERS

- Power & Harmonics Analyzer
- Energy Auditor
- Clamp-On Harmonics & Leakage Testers
- 3Φ / 1Φ Clamp-On Power & Energy Meters
- Clamp-On / Flexible CT's

CALIBRATING EQUIPMENT

- Universal Calibrator
- Multifunction Calibrator
- AC Multifunctional Power Calibrator
- Multifunctional Process Calibrator
- Standard Current Coil

SOLAR ANALYZER

- Solar Module Analyzer
- Solar System Analyzer
- Solar Power Meter

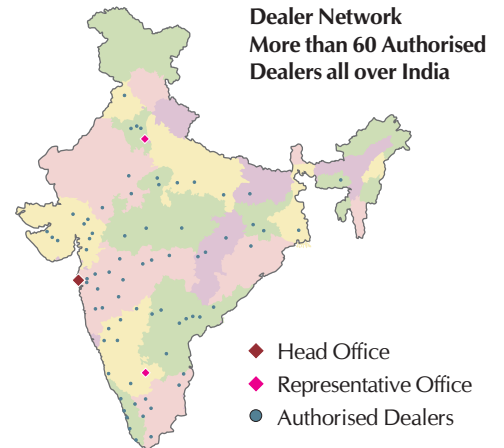

Industry Segments			Exports To Over 30 Countries			
Automobile	Food Processing	Refractories	Bahrain	France	Kenya	Saudi Arabia
Automation	Hotel & Tourism	Rubber & Plastic	Bangladesh	Germany	Kuwait	Singapore
Aviation	Mining & Metallurgy	SCADA	Brazil	Ghana	Lebanon	Spain
Cement	Oil /Gas/ Petroleum	Shipping	Chile	Greece	Malaysia	South Africa
Cellular Service Provider	Paper	Sugar Plants &	Denmark	Iran	Morocco	Syria
Chemical	Petrochemical	Distilleries	Dubai	Inodonesia	Netherlands	Thailand
Defence	Pharmaceutical	System Houses/	Egypt	Israel	Oman	UK
Educational Institutions	Power Utilities	Integrators	Ethiopia	Italy	Philippines	USA
EEE Manufacturer	R & D Organization	Telecommunication	Finland	Kampala	Qatar	
Fertilizer	Railway	Textile Plants /Mills				

On Approved List of Major Consultants and Customers			
ABB	EMCO	KPCL	PDIL
ACC	Emerson	Keltron	Reliance Energy Ltd.
Airport Authority of India	Easun Reyrolle Limited	L&T	R.P.G.
ALIND	ECIL	Madras Cement Ltd.	Rockwell Automation
Ambuja Cement Ltd.	GE	Mahindra & Mahindra Ltd.	RCF Limited
Andhra Sugars Ltd.	Grasim Industries Limited	Maihar Cement Limited	RIL
APLAB Limited	GSEB	Maruti Udyog Limited	RRVPNL
A. P. Power Generation	Gail India Limited	Ministry of Defence	SAIL
Areva T & D	Godrej & Boyce	MPEB	Sardar Patel College Of Engg.
Bajaj Auto Limited	Hindalco Industries Limited	MRPL	Siemens Limited
Bharati Shipyard Ltd.	Hindustan Zinc Limited	MTNL	Schenk Rotec (I) Ltd.
BHEL	Honeywell Automation Limited	MSEDCL (Mahadiscom)	Suzlon
BSES	HPCL	MSETCL	Tata Chemicals Limited
BSNL	IIT	MahanagarGas Limited	Tata Power Limited
BEST	Indian Oil Corporation Limited	NALCO	TELCO Limited
Blue Star Limited	Indian Railways	NFL	TISCO Limited
BPCL	IPCL	NHPC	TNEB
Bharti Airtel	ISRO	N PC	Toyota Limited
Crompton Greaves Limited	Indian Ordnance Factory	NTPC	UPPCL
C&S Group	JVVNL	ONGC	Vikram Sarabhai Space Centre
Deccan Cement Limited	KSEB	Orient Paper Mills Limited	Visakhapatnam Steel Plant
Dept. of Atomic Energy (BARC)	Kirloskar Electric Limited	PCI Ltd.	Wipro
Essar Steel Limied		PGCIL	Yokogawa Limited

Product Certifications by Accredited Laboratories

Particulars	Certificate No
Analog Instruments	
Type Test Reports	
● Moving Iron AC Panel Meter - SQ72	ERTL (W)/2002 E & S 294
● Moving Iron AC Volt Meter - SQ96	ERTL (W)/2002 E & S 295
● Moving Coil AC Rectifier Type Meter - MLC96	ERTL (W)/2002 E & S 290
● Moving Coil AC Rectifier Type Meter - C72	ERTL (W)/2002 E & S 288
● Moving Coil AC Rectifier Type Meter - C 96	ERTL (W)/2002 E & S 287
● Moving Coil DC Volt Meter - M72	ERTL (W)/2002 E & S 285
● Moving Coil DC Volt Meter - M96	ERTL (W)/2002 E & S 286
● Moving Coil DC Panel Meter - ML96	ERTL (W)/2002 E & S 289
● Electronic Analog Type Watt Meter - 96QW33	ERTL (W)/2002 E & S 291
● Electronic Analog Type Frequency Meter - F96	ERTL (W)/2002 E & S 293
● Electronic Analog Type Power Factor Meter - 96QF31	ERTL (W)/2002 E & S 292
● Electronic Analog Insulation Tester - MC904A-2	ERTL (W)/2004 E & S 284
● Electronic Analog Insulation Tester - MC907A-2	ERTL (W)/2004 E & S 285
EMI and EMC Test Reports	
● Electronic Analog Type Frequency Meter - F72	ERTL (W)/1998 EMI 00088
● Moving Coil AC Rectifier Type Meter - MLC96	ERTL (W)/1998 EMI 00089
● Maximum Demand Ammeter - BM96S	ERTL (W)/1998 EMI 00090
Safety Test Reports	
● Electronic Analog Type Frequency Meter - F72	ERTL (W)/1998 SAF 0046
● Moving Coil AC Rectifier Type Meter - MLC96	ERTL (W)/1998 SAF 0047
● Maximum Demand Ammeter - BM96S	ERTL (W)/1998 SAF 0048
Digital Instruments	
Type Test Reports / Calibration Report	
● Digital AC Volt Meter - SMP35S	ERTL (W)/2004 E & S 276
● Digital AC Current Meter - SMP35SRS	ERTL (W)/2004 E & S 277
● Digital DC Volt Meter - SMP35S	ERTL (W)/2004 E & S 282
● Digital Frequency Meter (4 Digit) - FDM3BS	ERTL (W)/2004 E & S 278
● Digital Frequency Meter (5 Digit) - FDM5BS	ERTL (W)/2004 E & S 279
● Digital Power Factor Meter - DPF 31	ERTL (W)/2004 E & S 281
● Digital Watt Meter - DWM9634	ERTL (W)/2004 E & S 280
● Clamp-On TRMS Power Meter - 3510PHW	ERTL (W)/2008 E & S 357
● Clamp-On Earth / Ground Resistance & Leakage Current Tester - 4680	ERTL (W)/2003 E & S 258
● Digital Insulation Tester - DIT99C	ERTL (W)/2004 E & S 286
● Digital Insulation Tester - DIT99D	ERTL (W)/2004 E & S 287
● Multifunction Calibrator - 90DQ	CC/ECL/1021/08-09
● AC Multifunction Calibrator - 90P	CC/ECL/979/09-10
● 4 Digit Frequency Meter	ERTL (W)/2011 E & S 11
EMI and EMC Test Reports	
● Digital Multi Meter - 9A02	ERTL (W)/2002 EMI 150
● Power Line Supervisor / Universal Electrical Analyzer - SPVR-96	ERTL (W)/2002 EMI 147
● Digital Watt Meter - DWM33	ERTL (W)/2002 EMI 148
● Digital AC Current Meter - SMP35SRS	ERTL (W)/2004 EMI 365
● Clamp-On Earth / Ground Resistance & Leakage Current Tester - 4680	ERTL (W)/2004 EMI 234
● 3½ Digital Panel Meter - SMP35SRS	ERTL (W)/2004 EMI 365
Safety Test Reports	
● Power Line Supervisor / Universal Electrical Analyzer - SPVR-96	ERTL (W)/2002 SAF 46
Power Line Transducers	
Type Test Reports	
● AC Current Transducer - CMT	ERTL (W)/2003 E & S 117
● AC Voltage Transducer - VMT	ERTL (W)/2003 E & S 26
● Frequency Transducer - FT	ERTL (W)/2003 E & S 27
● AC Current Transducer (Self Powered) - CMT	ERTL (W)/2004 E & S 283
EMI and EMC Test Reports	
● Active (Watt) Power Transducer - WT34	ERTL (W)/2002 EMI 149
● AC Voltage Transducer - VMT	ERTL (W)/2003 EMI 262
● Frequency Transducer - FT	ERTL (W)/2003 EMI 263
● Current Transducer with 19V to 90V DC Aux. Supply - CMT	ERTL (W)/2003 EMI 324
● Current Transducer with 85V to 265V AC Aux. Supply - CMT	ERTL (W)/2003 EMI 327
● Voltage Transducer with 19V to 90V DC Aux. Supply - VMT	ERTL (W)/2003 EMI 325
● Voltage Transducer with 85V to 265V AC Aux. Supply - VMT	ERTL (W)/2003 EMI 328
● Watt Transducer with 19V to 90V DC Aux. Supply - WT11	ERTL (W)/2003 EMI 326
● Watt Transducer with 85V to 265V AC Aux. Supply - WT11	ERTL (W)/2003 EMI 329
● Current Transducer with Self Powered Aux. Supply - CMT	ERTL (W)/2004 EMI 366
● Current Transducer - CMT	ERTL (W)/2004 EMI 346
● AC Voltage Transducer - VMT	ERTL (W)/2004 EMI 347
● Frequency Transducer - FT	ERTL (W)/2004 EMI 348
● Power Factor Transducer - PFT31	ERTL (W)/2004 EMI 349
● Active Power Transducer - WT33	ERTL (W)/2004 EMI 350
● Reactive Power Transducer - RPT33	ERTL (W)/2004 EMI 351

Quality Control Facilities

For Electrical / Electronic QC

- Fluke 5500A Calibrator
- Fluke 5100B, 5220A (Transconductance Amplifier) AC/DC Calibrator
- Yokogawa 2558 AC STD Source
- Yokogawa 2553, 2563, 2564 DC STD Source
- Yokogawa 2533 AC / DC STD Power Meter
- AC 3 Phase Test Bench
- AC Single Phase Test Bench
- YEW 2793 Decade Resistance Box
- HP 34401A 6½ Digit Multimeter
- MECO 65P 6½ Digit Digital Multimeter
- YEW 2885 Standard Watt Converter
- Ampere (Italy) 3 Phase AC Calibrator Model 74T
- RFL - Phase Generator Model 809
- OSAW Senior Kelvin Double Bridge
- Universal Calibrator MECO 90A

- Multifunctional Calibrator MECO 90DQ
- DIT99E
- MECO Standard Ammeter FS 216
- AC Multifunctional Calibrator MECO90P
- Process Calibrator MECO333
- Jigs / Fixtures for PCB Assembly, Calibration & Final Testing
- Resistor Banks for MΩ / GΩ for Insulation Tester Measurement

For Mechanical (Dimensional) QC

- World class Measuring Instruments & Facility with an In-House Tool Room

For Type Test QC

- Vibration Table ● Environmental Chamber
- Life Tester ● Equipment for Damping Test
- High Voltage Tester ● Insulation Tester
- Hair Spring Torque Tester
- Stereo Microscopes 40X, e-Microscope
- Oscilloscopes, DMMs etc. ● Bursting Strength Machine

Echelon of Standards at MECO (Traceable to NPL Standards)

Acc.	Para	Resistance	D.C.Volts	D.C.Amps	A.C.Volts	A.C.Amps	Watt	Var	P.F. / φ	Hz	Capacitance	Temperature
0.002%		H.P. 34401A D.M.M.	H.P. 34401A D.M.M.									
0.003%		Fluke 5100B Calibrator										
0.004%			● Fluke 5100B ● Fluke 5500A Calibrators									
0.005%			MECO 65P									
0.006%										H.P. 34401A DMM		
0.008%												
0.01%		● YEW2793 Decade Box ● MECO 65P		Fluke 5500A Calibrator								
0.015%				Fluke 5100B Calibrator						MECO90P Calibrator		
0.02%		Chitai Ohmmeter	● YEW 2553 D.C. Voltage Current std. ● MECO90DQ Calibrator	● YEW 2553 D.C. Voltage Current std. ● MECO90DQ Calibrator			YEW 2885 Watt Converter					
0.025%				MECO333 Calibrator								
0.03%		MECO90A Calibrator	MECO90A Calibrator	MECO90A Calibrator	● Fluke 5500A Calibrator ● MECO90P Calibrator	MECO90P Calibrator					● MECO90P Calibrator ● MECO333 Calibrator	
0.035%					Fluke 5100B Calibrator							
0.05%		OSAW Senior Kelvin Double Bridge	MECO333 Calibrator	● MECO 65P ● HP 34401A	● MECO90A Calibrator ● MECO90DQ Calibrator	● Fluke 5100B Cal. ● MECO90A Cal. ● MECO90DQ Cal.					KDK DPF-30 Phase-freq. Meter	
0.06%						MECO FS216						
0.07%			MECO Shunt 50A/100mV(2mΩ)									
0.08%				YEW 2558 A.C. Volt/Amp. Source	● YEW 2558 A.C. Volt/Amp. Source ● Fluke 5100B Calibrator	MECO90P Calibrator	MECO90P Calibrator					
0.1%				● Fluke 8800A DMM ● Ampere 74T	● H.P. 34401A DMM ● Ampere 74T ● MECO 65P	YEW 2533 Power Meter					● MECO90A Calibrator ● MECO90DQ Calibrator	● Fluke 5500A Calibrator ● MECO333 Calibrator
0.15%		YEW 2563 Voltage Unit										
0.2%		● MECO90A Calibrator ● MECO90DQ Calibrator		YEW 2564 Current Unit			● Ampere 74T ● Fluke 5500A Calibrator	● Ampere 74T ● Fluke 5500A Calibrator	● Ampere 74T ● Fluke 5500A Calibrator		Fluke 5500A Calibrator	
0.5%		YEW Analog Meter	YEW Analog Meter	YEW Analog Meter	YEW Analog Meter	YEW Analog Meter			KDK DPF-30 RFL 809			
1.0%											Balcon Decade Cap. Box	
3.0%		2000MΩ/1000V DIT99E										

Plant & Machinery

- BFW Milling Machine with 3 axis DRO
- Kirloskar Lathe Machine
- Batliboi Shaping Machine
- Radial Drilling Machine
- Drilling Machines 13mm
- Tapping Machines 6.5mm
- Bench Grinder
- Pentograph
- Tool Bit Grinder
- Tanabe (Japan) Coil Winding Machines
- Industrial oven for Burn-In/Aeaging Test/Burn-in Chamber
- Automatic Transformer Test System
- Magnetisers
- Impulse Magnetiser
- Ultrasonic Cleaner
- Oil Dispenser
- MECO DC regulated Power Supply cum Rectifier Unit
- Moulding Machine
- Air Compressor
- In House CAD Facility
- Dial Designer
- Belt Conveyor System
- Box Strapping Machine
- Plastic Scrap Grinding Machine
- Slitting Machine

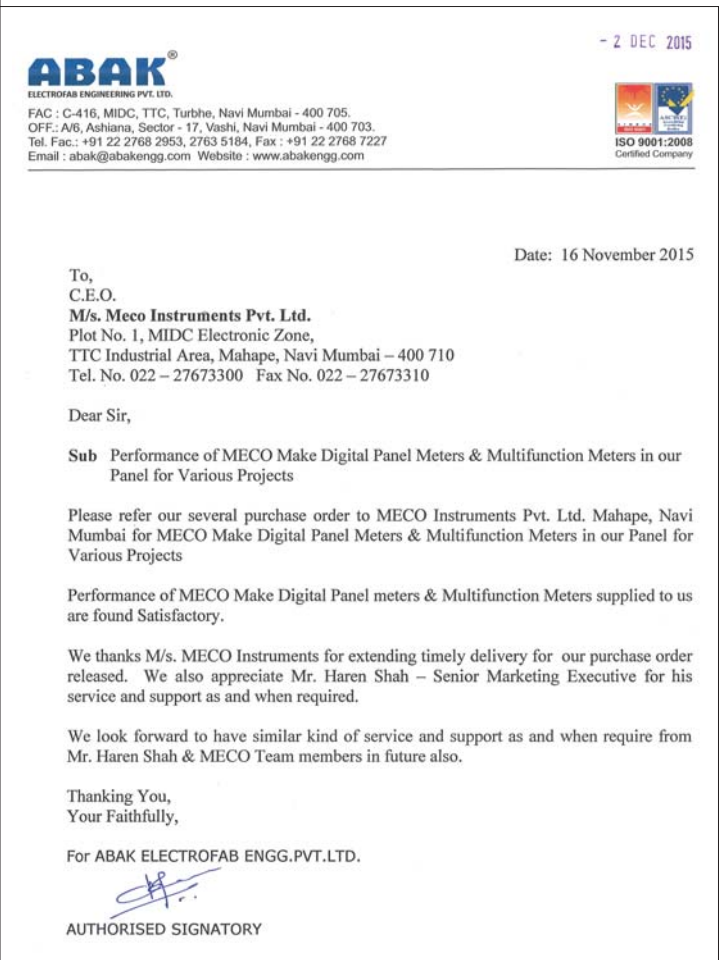



SINCE 1962

Multifunction Meters



Reliable, Long-Lasting and Affordable Instruments ...since 1962 !

www.mecoinst.com

An ISO 9001-2008 Certified Company

MECO INSTRUMENTS PRIVATE LTD.
NAVI MUMBAI

FEATURES / PARAMETERS		MFM-96UE / MFM-96UMT	MFM-144x192UE / MFM-144x192UMT	SPVR-96UE / SPVR-96UMT	MFM-96S with SMPS HV/LV Power Supply	SPVR-96S with SMPS HV/LV Power Supply	MFM Din Rail	MFM-96AF
TRMS Measurement		✓	✓	✓	✓	✓	✓	✓
Display	LED- Super Bright	✓	✓	-	✓	-	-	✓
	LCD- With Backlight	-	-	✓	-	✓	✓	-
Communication	RS 485 MODBUS, 5KV Isolated Port	✓	✓	✓	✓	✓	✓	✓
System	3 Phase 3 Wire System	-	-	-	✓	✓	✓	✓
	3 Phase 4 Wire System (Balanced/Unbalanced)	✓	✓	✓	✓	✓	✓	✓
Aux. Supply	110V / 230V AC	✓	✓	✓	✓	✓	-	✓
	48/110/220VDC (Any one only)	----- Under Development -----			✓	✓	-	-
	SMPS HV(85-265V AC / DC)	-	-	-	✓	✓	-	✓
	SMPS LV(19 - 90V AC / DC)	-	-	-	✓	✓	✓	-
Current	I1, I2, I3	✓	✓	✓	✓	✓	✓	✓
	I12, I31	-	-	-	✓	✓	✓	✓
	I Average	✓	✓	✓	✓	✓	✓	✓
	Neutral Current	-	-	-	-	-	-	✓
Voltage	V1N, V2N, V3N	✓	✓	✓	✓	✓	✓	✓
	V12, V23, V31	✓	✓	✓	✓	✓	✓	✓
	V12, V31	-	-	-	✓	✓	✓	✓
	V System	✓	✓	✓	✓	✓	✓	✓
Frequency	Hz	✓	✓	✓	✓	✓	✓	✓
Active Power	W1, W2, W3,	✓	✓	✓	✓	✓	✓	✓
	W System	✓	✓	✓	✓	✓	✓	✓
Reactive Power	Var1, Var2, Var3,	✓	✓	✓	✓	✓	✓	✓
	Var System	✓	✓	✓	✓	✓	✓	✓
Apparent Power	VA1, VA2, VA3,	✓	✓	✓	✓	✓	✓	✓
	VA System	✓	✓	✓	✓	✓	✓	✓
Power Factor	PF1, PF2, PF3	✓	✓	✓	✓	✓	✓	✓
	PF System	✓	✓	✓	✓	✓	✓	✓
Active Energy	KWh1 (Import)KWh2 (Import), KWh3 (Import)	✓	✓	✓	✓	✓	✓	✓
	KWh Total (Import)	✓	✓	✓	✓	✓	✓	✓
	KWh1 (Export), KWh2 (Export), KWh3 (Export)	✓	✓	✓	✓	✓	✓	✓
	KWh Total (Export)	✓	✓	✓	✓	✓	✓	✓
Reactive Energy	KVARh1 (Ind.),KVARh2 (Ind.), KVARh3 (Ind.)	✓	✓	✓	✓	✓	✓	✓
	KVARh Total (Ind.)	✓	✓	✓	✓	✓	✓	✓
	KVARh1 (Cap.), KVARh2 (Cap.), KVARh3 (Cap.)	✓	✓	✓	✓	✓	✓	✓
	KVARh Total (Cap.)	✓	✓	✓	✓	✓	✓	✓
Apparent Energy	KVAh1, KVAh2, KVAh3	✓	✓	✓	✓	✓	✓	✓
	KVAh Total	✓	✓	✓	✓	✓	✓	✓
Energy Retention & Reset		✓	✓	✓	✓	✓	✓	✓
MAX. Demand	KW System / KVA System	MFM96 UMT	MFM144x192 UMT	SPVR96 UMT	-	-	-	KW or KVA System
THD	V1, V2, V3, I1, I2, I3	MFM96 UMT	MFM144x192 UMT	SPVR96 UMT	-	-	-	✓
Scroll - Auto / Manual		✓	✓	✓	✓	✓	✓	✓
Password Protection		✓	✓	✓	✓	✓	✓	✓
Inbuilt Memory to Programme, Store And Reset For	CTR	✓	✓	✓	✓	✓	✓	✓
	PTR	✓	✓	✓	✓	✓	✓	✓
	Instrument Address	✓	✓	✓	✓	✓	✓	✓
	MD Period	✓	✓	✓	✓	✓	✓	✓
	Password	MFM96 UMT	MFM144x192 UMT	SPVR96 UMT	-	-	-	✓
Phase Angle	R, Y, B	-	-	-	-	-	-	✓
Phasor Angle	RY, BY, BR	-	-	-	-	-	-	✓
RUN Hour	Import	-	-	-	-	-	-	✓
	Export	-	-	-	-	-	-	✓
	Total (Import + Export)	-	-	-	-	-	-	✓
ON Hours		-	-	-	-	-	-	✓
Voltage	Min. Value, Max Value	-	-	-	-	-	-	✓
Current	Min. Value, Max Value	-	-	-	-	-	-	✓

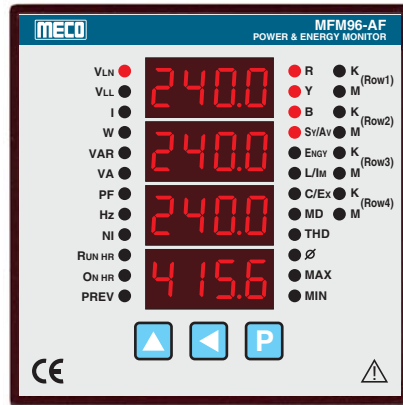

MFM-96AF

Features

- TRMS Measurement
- 23 Parameters on 46 Pages
- 4 Rows of 4 Digit Super Bright RED LED Display
- 3 Phase 3 Wire / 3 Phase 4 Wire System (User Selectable)
- Programmable CTR, PTR, Instrument Address, Password & MD Period

- Energy Import-Export (4 Quadrant Operation)
- IP54 (For Meter Front)
- POWER MASTER Software (Optional)
- RS485 Port, 5KV Isolated with MODBUS RTU Protocol (Optional)
- CE Compliance with EN61010-1, EN61326-1
- Inbuilt Memory to Store CTR, PTR, Instrument Address, Password & MD period
- Auto Scroll (5 sec.) / Manual Scroll Display
- Built in 20 Energy Meters of 8 Digit Resolution
- Energy Retention & Password Protected Energy Reset Facility
- Max. Demand for KW or KVA with user Selectable Demand Interval 5-30 Minutes
- THD for Voltage & Current
- Password for Protection of Programmable Parameters
- RUN Hours, ON Hours
- Phase Angle & Phasor Angle Measurement
- Display Previous Energies
- Set Date & Time
- Measurement of Min. & Max. Voltage & Current Values

Parameters Measured	Accuracy \pm (FS + 5Digit)	Phase	System
Voltage	$\pm 0.5\%$	V1N, V2N, V3N, V12, V23, V31	V (System)
Current		I1, I2, I3, NI	I (Average)
Active Power		W1, W2, W3	W (System)
Reactive Power	$\pm 1\%$	Var1, Var2, Var3	Var (System)
Apparent Power		VA1, VA2, VA3	VA (System)
Maximum Demand	$\pm 0.5\%$	W1, W2, W3, VA1, VA2, VA3	W (System), VA (System)
THD	$\pm 5\%$	V1, V2, V3, I1, I2, I3	NA
Frequency	± 0.2 Hz	NA	Hz (System)
Power Factor	$\pm 1^\circ$ Electrical	PF1, PF2, PF3	PF (System)
Active Energy		KWh1, KWh2, KWh3	KWh Total (Import), KWh Total (Export)
Reactive Energy	Class 1	KVarh1, KVarh2, KVarh3	KVarh Total (Ind.), KVarh Total (Cap.)
Apparent Energy		KVAh1, KVAh2, KVAh3	KVAh Total
Phase Angle	NA	V1V2, V1V3, V1I1, V2I2, V3I3	NA

Specifications

Display	Simultaneous Display of 4 Parameters, 4 Digits Resolution, 0.36" / 9.2mm Digit Height	Current Input	< 0.2VA / Phase	
		System	3P2E3W / 3P3E4W	
Auxiliary Supply	85 - 265V AC / DC	Standard		
		Installation Category	Cat II (IEC / EN61010-1)	
Input	Voltage/Phase	Any one	Pollution	Degree 2 (IEC / EN61010-1)
			Environment	
51 - 300VAC (Max.) PH-N	17 - 138VAC (Max.) PH-N	Any one	Calibration	27°C \pm 5°C
			Operating	0 to 50°C, RH < 70%
88 - 519VAC (Max.) PH-PH	30 - 239VAC (Max.) PH-PH	Any one	Storage	-10 to 60°C, RH < 70%
			Terminal Block	Plug in type
0.050A to 1.2A (Max.)	0.250A to 6A (Max.)	Any one	Dimensions (mm)	
			Front	96 x 96mm
Frequency	45-65 HZ	Depth (Behind Bezel)	90mm	
Power Factor	0.300 Lag (L) - 1 .000 - 0.300 Lead (C)	Panel Cut-Out	92 ^(+0.8, -0.0) x 92 ^(+0.8, -0.0)	
VA Burden (Typical)		Dielectric Strength	2.5kV at 50Hz for 1 min.	
Auxiliary	< 2.5VA	Insulation Resistance	> 20MOhms at 500V DC	
Voltage Input	< 0.3VA / Phase			

Ordering Information : Model, Input Voltage, Input Current, Input Frequency and RS485 MODBUS Communication (Optional)

Terminal Connection

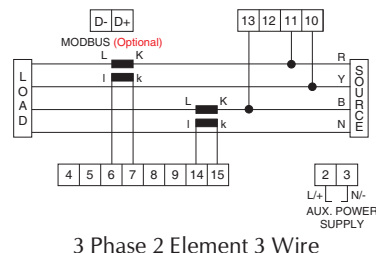
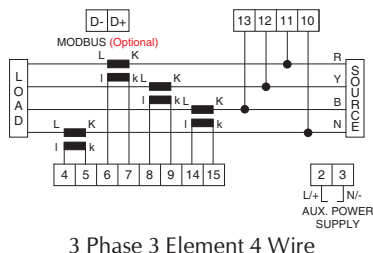

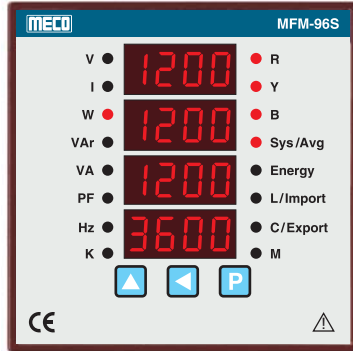

MFM-96S

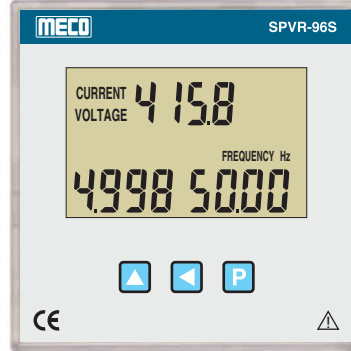

SPVR-96S

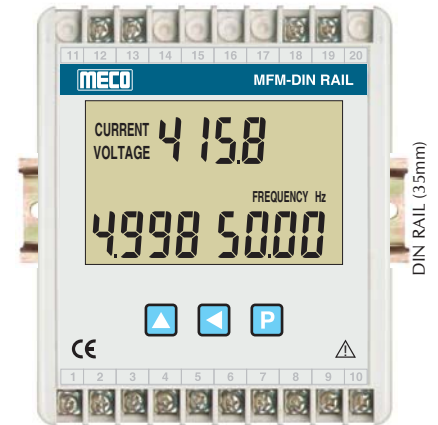

MFM-DIN RAIL

Features

- 10 Parameters, 48 Values on 16 Pages (MFM-96S)
- 10 Parameters, 50 Values on 34 Pages (SPVR-96S & MFM-DIN RAIL)
- TRMS Measurement
- 3 Phase 3 Wire / 3 Phase 4 Wire (User Selectable)
- CTR, PTR, Inst. Address, Password & Energy Reset (Programmable)
- Energy Import - Export (4 Quadrant Operation)
- POWER MASTER Software (Optional)
- RS485 Port, 5KV Isolated with MODBUS RTU Protocol (Optional)
- CE Compliance as per EN61010-1, EN61326-1
- Inbuilt Memory to Store CTR, PTR, Inst. Address & Password
- Auto / Manual Scroll Display (Programmable)
- Energy Retention
- Energy Reset Programmable Parameters (Password Protected)

Parameters Measured	Accuracy \pm (%FS)	Phase	System
Voltage	$\pm 0.5\%$	V1N, V2N, V3N, V12, V23, V31	V (System)
Current	$\pm 0.5\%$	I1, I2, I3	I (Average)
Active Power	$\pm 1.0\%$	W1, W2, W3	W (System)
Reactive Power	$\pm 1.0\%$	Var1, Var2, Var3	Var (System)
Apparent Power	$\pm 1.0\%$	VA1, VA2, VA3	VA (System)
Frequency	± 0.2 Hz	NA	Hz (System)
Power Factor	$\pm 1^\circ$ Electrical	PF1, PF2, PF3	PF (System)
Active Energy	Class 1	KWh1, KWh2, KWh3	Kwh Total (Import) & Kwh Total (Export)
Reactive Energy		KVarh1, KVarh2, KVarh3	KVarh Total (IND.) & KVarh Total (CAP.)
Apparent Energy		KVAh1, KVAh2, KVAh3	KVAh Total

Specifications

Auxiliary Supply	85 - 265VAC / DC (Standard) 19 - 90VAC / DC (Optional)	Current I/P	< 0.2 VA / Phase	
Voltage / Phase	51 - 300VAC (Max.) (PH-N) 16 - 138VAC (Max.) (PH-N) 88 - 519VAC (Max.) (PH-PH) 28 - 239VAC (Max.) (PH-PH)	Any one	System	3P2E3W / 3P3E4W (User Selectable)
			Standard	
			Installation category	CAT II (IEC / EN61010 - 1)
Current / Phase	0.03A to 1.2A (Max.) 0.110A to 6A (Max.)	Any one	Pollution	Degree 2 (IEC / EN61010 - 1)
			Environment	
			Calibration	27°C \pm 5°C
Frequency	45 - 55Hz	Operating	0 to 50°C , RH < 70%	
Power Factor	0.300 Lag (L) - 1.000 - 0.300 Lead (C)	Storage	-10 to 60°C , RH < 70%	
VA Burden (Typical)		Terminal Block	Screw Type	
Auxiliary	< 3 VA	Dielectric strength	2.5KV at 50 Hz for 1 min.	
Voltage I/P	< 0.3 VA / Phase	Insulation Resistance	> 20 MOhms at 500VDC	

* Dimension (mm)

Model	MFM-96S / SPVR-96S	MFM-DIN RAIL
Front	96 x 96	115 (L) x 96(W) x 60(D)
Depth (Behind Bezel panel)	43	
Cut - out	92 ^(+0.8,-0.0) x 92 ^(+0.8,-0.0)	
Case / Housing Material	DIN Black ABS, Dimension as per DIN 43700	ABS Gray
Mounting	Panel	DIN RAIL (35mm)
Mounting Clamps	Sturdy, Moulded Derlin with Suitable Hardware	
Terminals/Connectors	Terminal Block : Thermo Plastic (UL94V-0) with Tin Plated Brass Terminal	

Terminal Connection

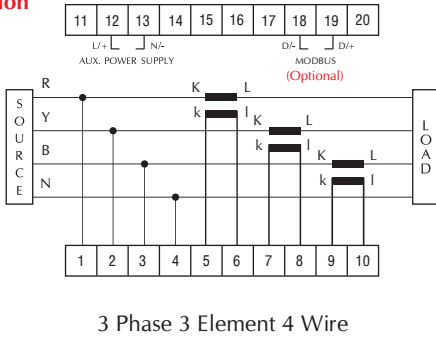

**SPVR-96S
MFM-96S**

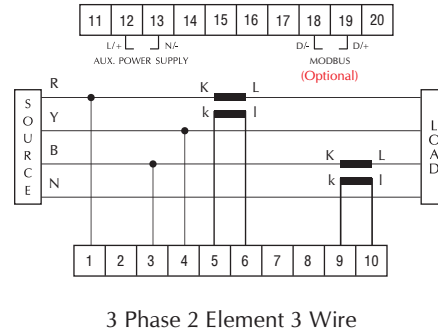

Terminal Connection

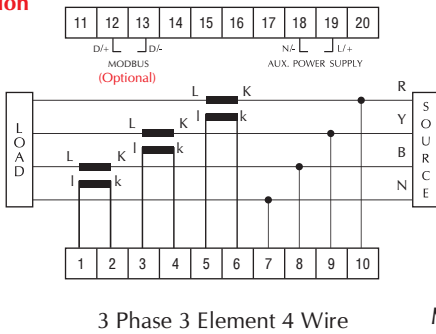

MFM-DIN RAIL

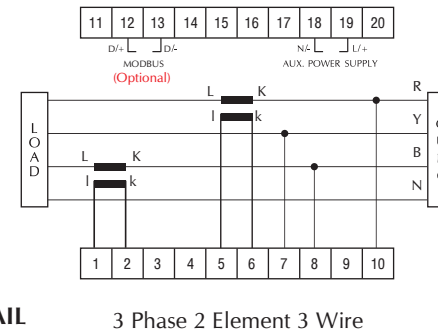

Ordering Information : Model, Input Voltage, Input Current, Input Frequency, System 3P3E4W / 3P2E3W, CTR / PTR (if any), Auxiliary Supply & RS485 MODBUS Communication Port (Optional)

RS485 - RS232 Converter



Features

- Half Duplex Transreceivers
- Data Transmission up to 1Mbps
- Compliance to TIA / EIA-485A Standard
- Allowing up to 32 Nodes on a Single Bus
- 5KV Isolation
- LED for Indicating RX / TX Data Flow
- Built in Power Supply

Application

- Energy Meter
- Industrial Automation
- Modem & Computers
- Telecommunication Equipment

Technical Specification

Model	RS485 - RS232 Converter	
Power Supply	85-265 V AC/DC	
Auxiliary (VA Burden)	< 2.5VA (Typical)	
Environment	Operating	0 to 60°C, RH < 70%
	Calibration	27°C ± 5°C
	Storage	-10 to 60°C, RH < 70%
Standard	TIA / EIA-485A	
Dimensions (mm)	85 x 60 x 38mm	

Terminal Connection

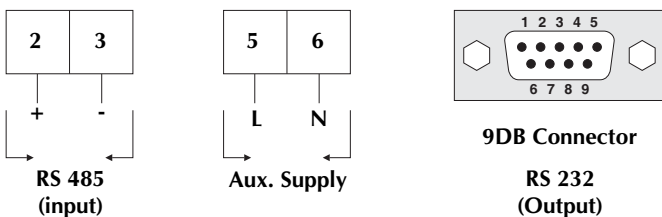

Ordering Information : Model



**SPVR-96UE
SPVR-96UMT**



**MFM-96UE
MFM-96UMT**



**MFM-144x192UE
MFM-144x192UMT**

Features

- TRMS Measurement
- 12 Parameters, 68 Values on 44 Pages (SPVR-96)
- 3 Groups of 4 Digit LCD with Backlight & Annunciators (SPVR-96)
- 12 Parameters, 68 Values on 22 Pages (MFM)
- 4 Rows of 4 Digit Super Bright Red LED Display (MFM)
- 3 Phase 4 Wire
- Programmable CTR, PTR, Instr. Address, Password & MD Period
- Energy Import-Export (4 Quadrant Operation)
- IP54 (for meter front)
- POWER MASTER Software (Optional)
- RS 485 Port, 5kV Isolated with MODBUS RTU Protocol (Optional)
- CE Compliance with EN61010-1, EN61326-1
- Inbuilt Memory to store CTR, PTR, Instr. Address, Password & MD Period
- Auto Scroll (5 sec.) / Manual Scroll Display
- Built-In 20 Energy Meters of 8 Digit Resolution
- Energy Retention & Password Protected Energy Reset Facility
- *Additional features for MFM-96UMT, SPVR-96UMT and MFM-144x192UMT
 - Max. Demand for KW & KVA with User Selectable Demand Interval 5-30 min.
 - THD for Voltage & Current
 - Password for Protection of Programmable Parameters

Parameters Measured	Accuracy \pm (%FS + 5 Digit)		Phase	System
	SPVR-96/MFM-96	MFM144x192		
Voltage	$\pm 0.2\%$	$\pm 0.5\%$	V1N, V2N, V3N, V12, V23, V31	V (System)
Current			I1, I2, I3	I (Average)
Active Power	$\pm 0.5\%$	$\pm 1\%$	W1, W2, W3	W (System)
Reactive Power	$\pm 1\%$	$\pm 1\%$	Var1, Var2, Var3	Var (System)
Apparent Power	$\pm 0.5\%$	$\pm 1\%$	VA1, VA2, VA3	VA (System)
*Maximum Demand	$\pm 0.5\%$	$\pm 1\%$	W1, W2, W3, VA1, VA2, VA3	W (System), VA (System)
*THD	$\pm 5\%$		V1, V2, V3, I1, I2, I3	NA
Frequency	± 0.2 Hz		NA	Hz (System)
Power Factor	$\pm 1^\circ$ Electrical		PF1, PF2, PF3	PF (System)
Active Energy	Class 1		KWh1, KWh2, KWh3	KWh Total (Import), KWh Total (Export)
Reactive Energy			KVarh1, KVarh2, KVarh3	KVarh Total (Ind.), KVarh Total (Cap.)
Apparent Energy			KVAh1, KVAh2, KVAh3	KVAh Total

Specifications

Display	SPVR-96	MFM-96	MFM144x192	System	3 P 3E 4W	
Viewing Area	44 x 68mm	Digit Height 0.36" / 9.2mm	Digit Height 1" / 25.4mm	Standard		
Auxiliary Supply	110 / 230V AC $\pm 20\%$ (Any One) 48V DC / 110V DC / 220V DC $\pm 20\%$ (Any One) Under Development			Installation Category	Cat II (IEC / EN61010-1)	
Input				Pollution	Degree 2 (IEC / EN61010-1)	
Voltage/Phase	50 - 300V (Max.) (PH-N)			Environment		
Current/Phase	0.2A to 1.2 A (Max.) or 1A to 6A (Max.) (Any One Only)			Calibration	27°C \pm 5°C	
Frequency	45-55 Hz			Operating	0 to 50°C, RH < 70%	
Power Factor	0.300 Lag (L) - 1.000 - 0.300 Lead (C)			Storage	-10 to 60°C, RH < 70%	
VA Burden (Typical)				Dimensions (mm)	SPVR-96/MFM-96	MFM144x192
Auxiliary	< 5VA			Front	96 x 96mm	144 x 192mm
Voltage Input	< 0.1VA / Phase			Depth (Behind Bezel)	90mm	60mm
Current Input	< 0.5VA / Phase			Panel Cut-Out	92 ^(+0.8, -0.0) x 92 ^(+0.8, -0.0)	138 ^(+0.8, -0.0) x 186 ^(+0.8, -0.0)
				Dielectric Strength	2.5kV at 50Hz for 1 min.	
				Insulation Resistance	> 20MOhms at 500V DC	
				Terminal Block	Plug in type	Screw type

Ordering Information : Model, Input Voltage, Input Current, Input Frequency, System 3P3E4W, CTR / PTR (if any), Auxiliary Supply & RS485 MODBUS Communication Port (Optional)

Terminal Connection

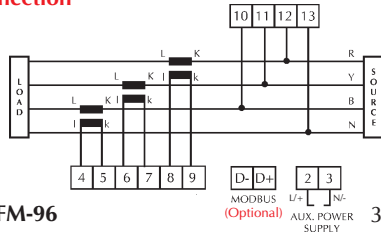

SPVR-96/MFM-96

3 Phase 3 Element 4 Wire

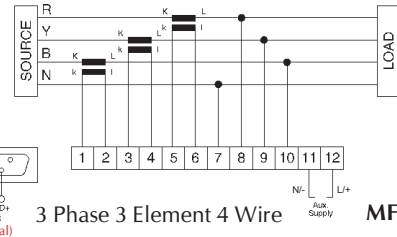

MFM144x192

Power Master Software



Power Master is a user interface software utility supplied along with MECO Multifunction Power & Energy Monitor, Power Line Supervisor & Universal Electrical Analyzer. It is ideal for remote monitoring and storage of the measured parameters on the PC. These parameters can be grouped into tables or graphs for analysis and management of the electrical system. The software has various features like real time display, tabular representation and graphical display of measured and stored values, history trends, alarms settings for maximum / minimum values etc. It also converts the tabular values to Excel format for further data processing and import into other software platforms.

Real Time Values	Real Time Graphs	History Trends	Report	Alarms

The software is available for operating systems from Windows 95 onwards.

The minimum hardware requirements at customer side are as follows :

- IBM Compatible PC
- 8 MB RAM Memory
- RS485/RS232 Converter
- 1 COM Serial Port for RS-232/RS-485
- 1.4GB Disk Space
- VGA Graphic Board

Installation Procedure

1. Place CD in the drive. It will automatically run the set-up.
2. A window to confirm the installation of Power Master will be displayed. Click "Next" to continue and installation and "Exit" to abort installation.
3. Next window displays information about the license agreement. Read it and if acceptable, then click "Next".
4. Now next window will ask for the directory in which Power Master software is to be installed.
5. Now click "Start" to start the installation.
6. When installation is successfully completed a window will confirm the success of the installation operation, press "Next".
7. Now click "Exit".

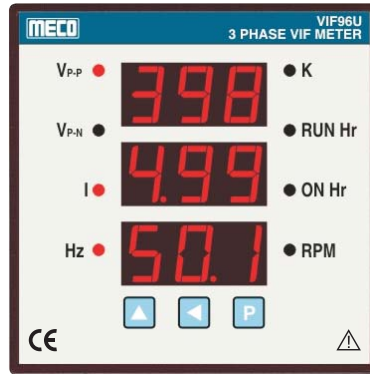

VIF96U

Features

- TRMS Measurement
- Measures V, A, Hz, Run Hour, ON Hour & RPM
- RUN Hour / ON Hour (Max. 99999 Hours, 59 Minutes, 59 Second)
- RUN Hour / ON Hour Reset Facility
- Auto Scroll / Manual Scroll Display
- 3 Phase 4 wire
- 3 Rows of 3 Digits Super Bright Red LED Display
- Programmable CTR, PTR, Number of Pole Setting
- Auto Indication for 'KV' & 'KA'
- Auto Selection of Decimal Point

Parameters Measured	Accuracy ± (%FS)	Phase	System
Voltage	± 0.5%	VRN, VYN, VBN, VRY, VYB, VBR	V (System)
Current	± 0.5%	IR, IY, IB	I (Average)
Frequency	± 0.2 Hz	NA	Hz (System)
RPM	± 0.5%	NA	RPM (System)
RUN Hour	NA	NA	RUN Hour (System)
ON Hour	NA	NA	ON Hour (System)

Specifications

Display	3 Rows of 3 Digit RED Seven Segment Display 0.56" / 14.2mm Digit Height		Voltage Input	< 0.2 VA / Phase
			Current Input	< 0.2 VA / Phase
Auxiliary Supply	85 - 265 V AC/DC (SMPS)		System	3 Phase 3 Element 4Wire
	19 - 90 V AC/DC (SMPS) (Under Development)		Standard	
Input Voltage	51 - 300 V AC (Max.) (PH - N)	Any one	Installation Category	Cat II (IEC / EN61010 - 1)
	21 - 150 V AC (Max.) (PH - N)		Pollution	Degree 2 (IEC / EN61010 - 1)
	88 - 519 V AC (Max.) (PH - PH)	Any one	Environment	
	36 - 258 V AC (Max.) (PH - PH)		Calibration	27°C ± 5°C
Input Current	0.5 A to 6 A (Max.) For 5A Meter	Any one	Operating	0 to 50°C, RH < 70%
	0.1 A to 1.2 A (Max.) For 1A Meter		Storage	-10 to 60°C, RH < 70%
Frequency	45 - 55 Hz		Dimensions (mm)	
RPM	As per Number of Pole Setting. Fully Programmable (1 - 255)		Front	96 x 96 mm
			Depth (Behind Bezel)	43 mm
			Panel Cutout	92 (+0.8, - 0.0) x 92 (+0.8, - 0.0)
VA Burden (Typical)			Dielectric Strength	2.5 KV at 50 Hz for 1 min
Auxiliary	< 2.5 VA		Insulation Resistance	> 20 MOhms at 500 V DC

Ordering Information : Model, Input Voltage, Input Current, Input Frequency, System 3P3E4W & Auxiliary Supply

Terminal Connection

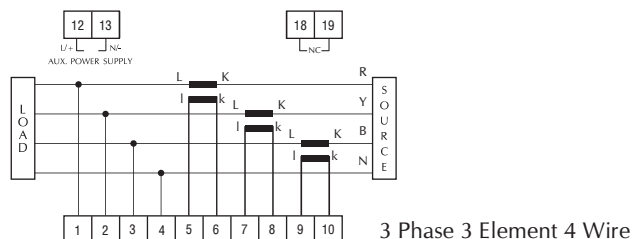

FEATURES / PARAMETERS		EM-08 (20A AC)	EM-08S (1A/5A AC)	EM-09	EM-08 / EM-08D
TRMS MEASUREMENT		✓	✓	✓	✓
DISPLAY	LCD (With Backlight)	✓	✓	✓	✓
COMMUNICATION	RS 485 MODBUS, 5KV Isolated Port	✓ (Optional)	✓ (Optional)	✓ (Optional)	—
SYSTEM	1 Phase	✓	✓	✓	✓
AUX. SUPPLY	230V AC	—	—	—	✓
	SMPS (85-265V AC/DC)	✓	✓	✓	—
CURRENT	I	✓	✓	✓	✓
VOLTAGE	V (P-N)	✓	✓	✓	✓
FREQUENCY	Hz	✓	✓	✓	✓
ACTIVE POWER	W	✓	✓	✓	✓
REACTIVE POWER	Var	✓	✓	✓	✓
APPARENT POWER	VA	✓	✓	✓	✓
POWER FACTOR	PF	✓	✓	✓	✓
ACTIVE ENERGY	KWh (Import)	✓	✓	✓	✓
REACTIVE ENERGY	KVARh (Ind.)	✓	✓	✓	✓
APPARENT ENERGY	KVAh	✓	✓	✓	✓
ENERGY RETENTION & RESET		✓	✓	✓	✓
SCROLL - AUTO / MANUAL		✓	✓	✓	✓
INBUILT MEMORY TO PROGRAMME, STORE AND RESET FOR	CTR	—	✓	—	✓
	INSTRUMENT ADDRESS	✓	✓	✓	—



MECO supports Bureau of Energy Efficiency (BEE), Govt. of India's mission to institutionalize certification of Electric / Electronic goods for ECOMARK under Gazette of India



EM-08(5A)
EM-08(1A)



EM-08D(5A)
EM-08D(1A)

Features

- 10 Parameters on 10 Display Pages
- Measures V, A, PF, Hz, KW, KVA, KVAh, KVAh & KVArh
- Auto / Manual Scroll Display (User Selectable)
- Reduces Panel Space and Wiring Time
- State of The Art Microcontroller Design
- TRMS Measurement
- Ideal for Testing of Electrical Appliances
- User Programmable CT Ratio (1.00 - 99.99)
- LCD Display with Backlight (20mm Digit Height)

Application

- Appliance Testing ● Energy Audit ● QC ● Studying Energy Efficiency of Electrical Equipment ● Building Management Systems ● Power Management ● Generator / Motor Characteristics ● Plant Maintenance

Specification

Functions	EM-08/EM-08D(5A)	EM-08/EM-08D(1A)	Accuracy
RMS Voltage	50.0 ~ 300 Vrms		±(0.2% FS + 1 dgt.)
RMS Current (any one range only)	(0.25 ~ 6.0 Arms)	(0.05 ~ 1.2 Arms)	±(0.2% FS + 1 dgt.)
Active Power	0.012 ~ 1.800 KW	0.002 ~ 0.360 KW	±(0.5% FS + 1 dgt.) [Cosφ=0.3 to 1.000]
Apparent Power	0.012 ~ 1.800 KVA	0.002 ~ 0.360 KVA	±(0.5% FS + 1 dgt.)
Reactive Power	0.012 ~ 1.800 KVAh	0.002 ~ 0.360 KVAh	±(1.0% FS + 1 dgt.) [Sinφ=0.3 to 1.000]
Power Factor	0.3 Lag ~ 1.0 ~ 0.3 Lead		±(0.01 PF + 1 dgt.)
Line Frequency	45.00 ~ 65.00 Hz		± 0.1 Hz
Active Energy (KWh)	0000 ~ 9999 KWh		Class 1
Apparent Energy (KVAh)	0000 ~ 9999 KVAh		
Reactive Energy (KVArh)	0000 ~ 9999 KVArh		

Model	EM08	EM08D
Case / Housing Material	DIN Black ABS, Dimension as per DIN 43700	Portable Type, Desk Top Case with Tilt Stand
Mounting Clamps	Sturdy, Moulded Derlin with suitable Hardware	Desk Top Type
Terminals / Connectors	Terminal Block : Thermoplastic (UL94V-0) with Tin Plated Brass Terminal	For Input connections 10Amps Binding Post Terminals on the Front panel.
Auxiliary Power Supply	230VAC ±20%, 50Hz	230VAC ±20% 50Hz, Switch & Fuse for Aux. Supply at the Back, Supplied with 1-Phase Power Cord
Dimension (mm)	Front	96 x 96
	Depth (Behind Bezel Panel)	90
	Cut-Out	92 (+0.8, -0.0) x 92 (+0.8, -0.0)
		160 (W) x 110 (H) x 190 (D)

Ordering Information : Model, Input Voltage, Input Current (1A or 5A - any one only), CTR & Auxillary Supply

Connection Diagram

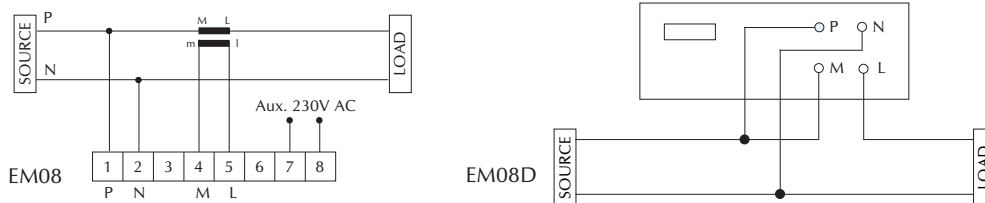

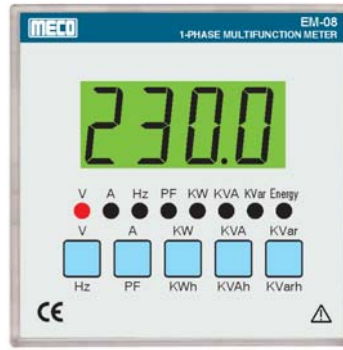

EM-08 (20A)
EM-08S (5A)
EM-08S (1A)

Features

- 10 Parameters on 10 Display Pages
- Measures V, A, PF, Hz, KW, KVA, KVAr, KWh, KVAh & KVArh
- Auto / Manual Scroll Display (User selectable)
- SMPS Power Supply (85 - 265VAC/DC)
- Ideal for Testing of Electrical Appliances
- User Programmable CT Ratio (1.00 - 99.99) for EM-08S (1A/5A)
- TRMS Measurement
- 4 Digit LCD Display with Backlight (20mm Digit Height) LED Indicator for Parameter Indication
- RS 485 Port (5KV Isolated) (Optional)
- MODBUS RTU Protocol (Optional)
- POWER MASTER Software (Optional)

Application

- Home Appliance Testing
- Energy Audit
- QC
- Studying Energy Efficiency of Electrical Equipment
- Building Management - Systems
- Power Management
- Generator/ Motor Characteristics
- Plant - Maintenance

Specification

Functions	EM-08 (20A)	EM-08S (5A)	EM-08S (1A)	Accuracy
RMS Voltage	50.0 ~ 300Vrms			± (0.5% FS + 1 dgt.)
RMS Current (Any One Range Only)	(0.9A ~ 24Arms)	(0.125A ~ 6.0Arms)	(0.025A ~ 1.2Arms)	
Active Power	0.216 ~ 7.200 KW	0.030 ~ 1.800 KW	0.006 ~ 0.360 KW	± (0.5% FS + 1 dgt.) [Cosφ = 0.3 to 1.000]
Apparent Power	0.216 ~ 7.200 KVA	0.030 ~ 1.800 KVA	0.006 ~ 0.360 KVA	± (0.5% FS + 1 dgt.)
Reactive Power	0.216 ~ 7.200 KVAr	0.030 ~ 1.800 KVAr	0.006 ~ 0.360 KVAr	± (1.0% FS + 1 dgt.) [Sinφ = 0.3 to 1.000]
Power Factor	0.3 Lag ~ 1.0 ~ 0.3 Lead			± (0.01 PF + 1 dgt.)
Line Frequency	45.00 ~ 55.00 Hz			± 0.1Hz
Active Energy (KWh)	0000 ~ 9999 KWh			Class 1
Apparent Energy (KVAh)	0000 ~ 9999 KVAh			
Reactive Energy (KVArh)	0000 ~ 9999 KVArh			

Note : KW / KVA / KVAr Measurements require Vrms x Irms x Cosφ/Sinφ ≥ 0.006 (for 1A Meter), ≥ 0.030 (for 5A Meter) and ≥ 0.216 (for 20A Meter)

Case / Housing Material	DIN Black ABS, Dimension as per DIN 43700		
Mounting Clamps	Sturdy, Moulded Derlin with suitable Hardware		
Terminals / Connectors	Terminal Block : Thermoplastic (UL94V-0) with Tin Plated Brass Terminal		
Auxiliary Power Supply	SMPS (85 - 265 VAC/DC)		
Dimension (mm)	Front	96 x 96	
	Depth (Behind Bezel Panel)	43 [For EM-08S(1A/5A)]	90 [For EM-08(20A)]
	Cut-Out	92 (+0.8, -0.0) x 92 (+0.8, -0.0)	

Ordering Information : Model, Input Voltage, Input Current (1A or 5A or 20A any one only) & RS485 Port (Optional)

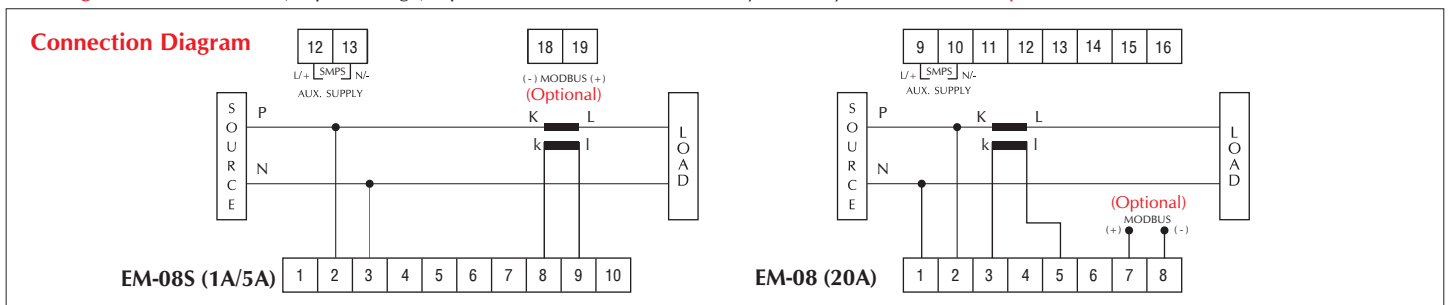

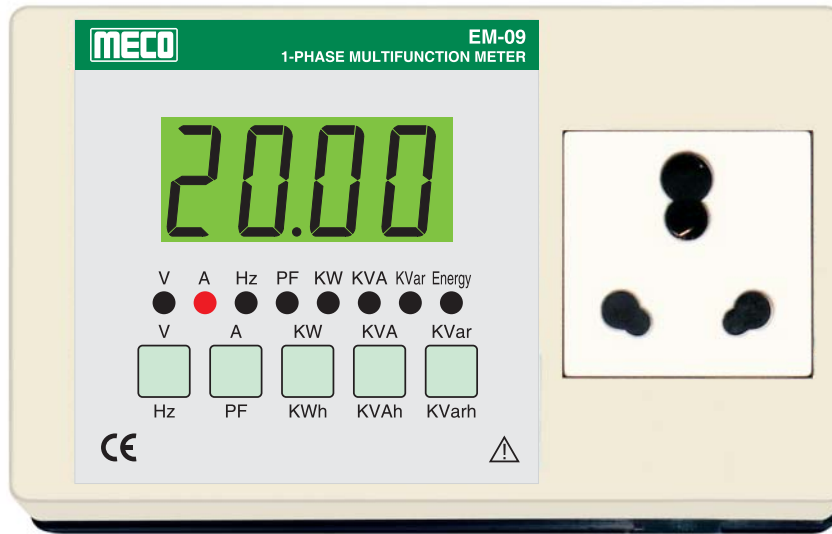

EM-09 (20A)
EM-09 (5A)
EM-09 (1A)

EM09 is a microcontroller based Portable, Continuous Use, Single Phase Electrical Meter indicating TRMS values of various electrical parameters. It measures 10 parameters on 10 display pages on a large LCD display (20mm). It has a smart socket. It is equipped with 5 keys to view all the parameters and for programming of the meter.

Features

- Measures V, A, PF, Hz, KW, KVA, KVar, KWh, KVAh & KVArh
- TRMS Measurement
- Can be used for Continuous Monitoring
- Auto / Manual Scroll Display (User Selectable)
- State of Art Microcontroller Design
- Portable, Easy to Carry and Simple to Use
- LCD Display with Backlight (Green & White)
- RS 485 Port (5kV Isolated) with MODBUS RTU Protocol (Optional)
- POWER MASTER Software for MIS Reports (Optional)

Application

- Appliances Testing (AC, Refrigerator, Washing Machine etc.)
- LED Lights Testing
- Can be given to Field Technicians in their Tool Kit
- Can be used by R&D Dept. in Designing Energy Efficient Products
- Energy Audit and Plant Maintenance
- Studying Energy Efficiency of Electrical Equipment
- Building Management Systems
- Power Management
- Product Quality Testing

Specification

Functions	EM-09 (20A)	EM-09 (5A)	EM-09 (1A)	Accuracy
RMS Voltage	85 ~ 265Vrms			± (0.5% FS + 1 dgt.)
RMS Current	(0.900A ~ 24Arms)	(0.125A ~ 6.0Arms)	(0.025A ~ 1.2Arms)	
Active Power	0.216 ~ 5.300 KW	0.030 ~ 1.590 KW	0.006 ~ 0.318 KW	± (0.5% FS + 1 dgt.) [Cosφ = 0.3 to 1.000]
Apparent Power	0.216 ~ 5.300 KVA	0.030 ~ 1.590 KVA	0.006 ~ 0.318 KVA	± (0.5% FS + 1 dgt.)
Reactive Power	0.216 ~ 5.300 KVAr	0.030 ~ 1.590 KVAr	0.006 ~ 0.318 KVAr	± (1.0% FS + 1 dgt.) [Sinφ = 0.3 to 1.000]
Power Factor	0.3 Lag ~ 1.0 ~ 0.3 Lead			± (0.01 PF + 1 dgt.)
Line Frequency	45.00 ~ 55.00 Hz			± 0.1 Hz
Active Energy (KWh)	0000 ~ 9999 KWh			Class 1
Apparent Energy (KVAh)	0000 ~ 9999 KVAh			
Reactive Energy (KVArh)	0000 ~ 9999 KVArh			

Note : KW / KVA / KVAr Measurements require Vrms x Irms x Cosφ / Sinφ ≥ 0.006 (for 1A Meter), ≥ 0.030 (for 5A Meter) and ≥ 0.216 (for 20A Meter)

Model	EM-09 (20A)	EM-09 (1A/5A)
Case / Housing	ABS Case Suitable for Desktop Mounting / Portable / Wall Mounting Application	
Socket / Plug	6A - 20A Multi Socket & 20A Plug	6A
Auxiliary Power Supply	85-265V AC Supplied with 1 Phase Power Cord	
Dimensions (mm)	164 x 100 x 65mm (approx.)	

Ordering Information : Model, Input Current (20A or 5A or 1A any one only) & RS485 Port (Optional)

Display Pages

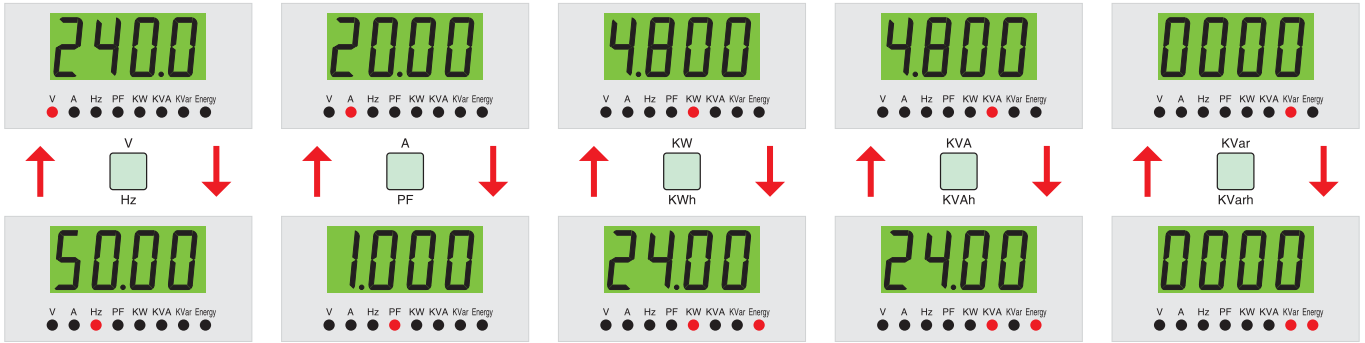

Applications



POWER MASTER Software

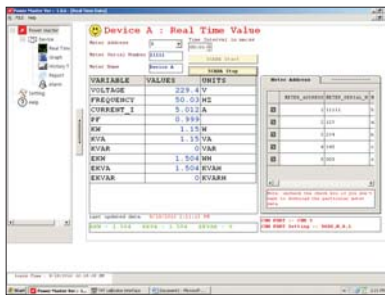

REAL TIME DISPLAY

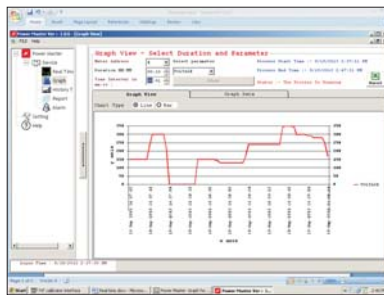

LINE GRAPH DISPLAY

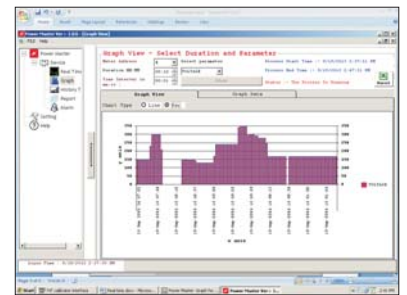

BAR GRAPH DISPLAY

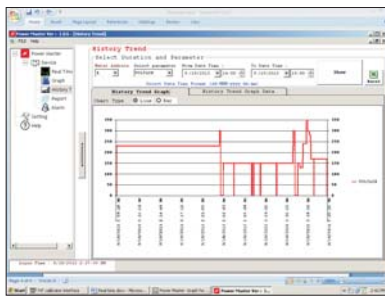

HISTORY TREND - LINE GRAPH DISPLAY

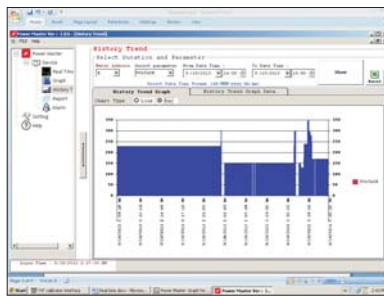

HISTORY TREND - BAR GRAPH DISPLAY

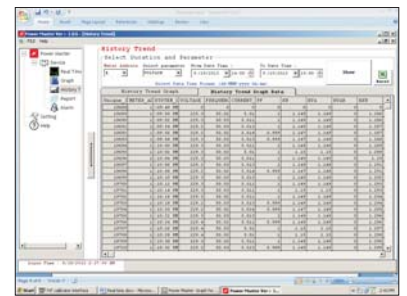

REPORT VIEW DISPLAY

MECO supports Bureau of Energy Efficiency (BEE), Govt. of India's mission to institutionalize certification of Electric / Electronic goods for ECOMARK under Gazette of India



PG07



PG08

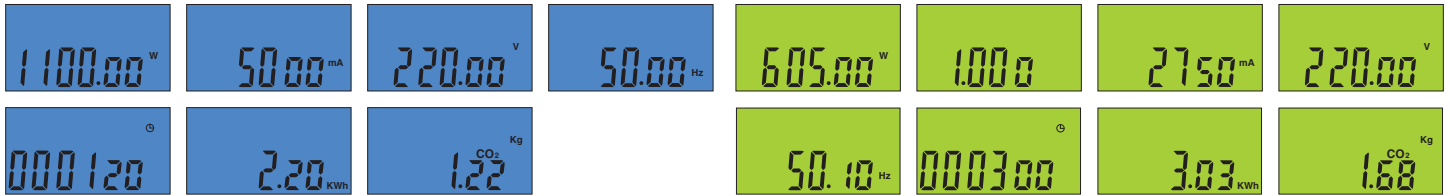

POWERGUARD is a simple to use and easy to handle product which can be widely used because of its portability and light weight.

Measures

- Power (W)
- Power Factor (PF) [PG08]
- Current (mA)
- Voltage (V)
- Frequency (Hz)
- Total Usage Time (min)
- Total Used Energy (KWh)
- Carbon Emission (CO₂ in kg)

Features

- Smart Three Pin Socket
- Large LCD Display with Backlight
- Memory Retention [KWh, min.]
- Blinking LCD to indicate Alarm when KW is over threshold
- Counts CO₂ generated by Electrical Equipment (0.555kg CO₂ is generated by using 1 KWh Energy)

General Specifications

- Accuracy : Class 1.0
- Power Consumption : Less than 1W
- Input : 220V, 50Hz, 10A (max.)
- Working Temperature : -25°C to +55°C
- Dimensions : 120 x 65 x 55mm (approx.)
- Weight : 130gms (approx.)

Specifications

Functions	Input Range (PG07)	Input Range (PG08)	Display Format	Accuracy (% of FS) (FS = 2200W)
Power (W)	0.2 ~ 1 W 1 ~ 5 W 5 ~ 2200 W	0.2 ~ 1 W 1 ~ 5 W 5 ~ 2200 W	XXXX.xx W	< 10 5 1
Power Factor	NA	For 0.2 ~ 5 W For 5 ~ 10 W For 10 ~ 2200 W	X.XXx	> 0.03 PF < 0.03 PF < 0.01 PF
Current (mA)	0.02 ~ 10 A	0.02 ~ 10 A	XXXxx mA	1
Voltage (V)	195 ~ 265 V	195 ~ 265 V	XXX.xx V	0.5
Frequency (Hz)	Hz	Hz	XX.xx Hz	NA
Total Usage Time (min.)	Minutes	Minutes	XXXXxx	NA
Total Used Energy (kWh)	For 5 ~ 2200 W	For 5 ~ 2200 W	XXXX.xx kWh	1
CO ₂ (Kg)	CO ₂ (Kg)	CO ₂ (Kg)	XXXX.xx CO ₂ Kg	NA
Applications	Teaching, Demonstration & Testing of Electrical Energy Consumption of Household / Office Appliances. It can be used in Houses, Offices, Shops, Schools, Laboratories etc.			

Ordering Information : Model



**PG09 - 20A
PG09 - 5A
PG09 - 1A**

Display Pages

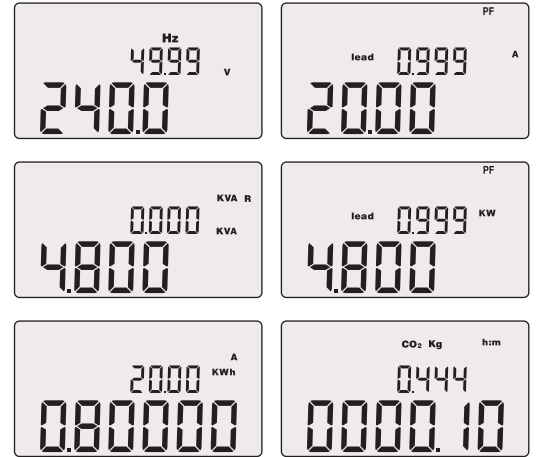

POWERGUARD is a simple to use and easy to handle product which can be widely used because of its portability and light weight

Measures

- TRMS Voltage (V)
- Frequency (Hz)
- TRMS Current (A)
- Power Factor (PF)
- Apparent Power (KVA)
- Reactive Power (KVAr)
- Active Power (KW)
- Energy Consumption (KWh)
- Energy Usage Time (EUT)
- Carbon Emission (CO₂ in kg)

Features

- Three Pin Socket & Plug Suitable for Indian Socket
- Large Dual Row LCD Display with Backlight & Annunciator
- Memory Retention (KWh, EUT)
- Simple, Easy & Accurate
- Continuous Measurement
- Counts CO₂ generated by Electrical Equipment (0.555kg CO₂ is generated by using 1KWh Energy)

General Specifications

- Accuracy : Class 1.0
- Power Consumption : Less than 2W (with backlight)
- Working Temperature : -10°C to +55°C, <70% RH
- Dimensions : 156 x 78 x 48mm (approx.)
- Weight : 300gms (approx.)

Specifications

Function	PG09 - 20A	PG09 - 5A	PG09 - 1A	Accuracy
RMS Voltage (V)	240V AC (Nominal) (195V ~ 265Vrms)			±0.5% of FS
RMS Current (A)	(0.110 ~ 20.00) Arms	(0.100 ~ 6.000) Arms	(0.020 ~ 1.200) Arms	±0.5% of FS
Active Power @240VAC (KW)	(0.026 ~ 4.800) KW	(0.024 ~ 1.440) KW	(4.800 ~ 288.0) W	±1.0% of FS
Apparent Power @240VAC (KVA)	(0.026 ~ 4.800) KVA	(0.024 ~ 1.440) KVA	(4.800 ~ 288.0) VA	±1.0% of FS
Reactive Power @240VAC (KVAr)	(0.026 ~ 4.800) KVAr	(0.024 ~ 1.440) KVAr	(4.800 ~ 288.0) VAR	±1.0% of FS
Power Factor (PF)	(0.026 ~ 0.120) KW	(0.024 ~ 0.096) KW	(0.021.6 ~ 0.048.0) W	>0.03 PF
	(0.120 ~ 4.800) KW	(0.096 ~ 1.440) KW	(0.048.0 ~ 288.0) W	<0.03 PF
Line Frequency (Hz)	45.00 ~ 55.00 Hz			±0.2 Hz
Active Energy (KWh)	000000 ~ 999999 KWh			Class 1
Energy Usage Time (EUT)	Hours / Minutes			NA
Carbon Emission (CO ₂ in kg)	CO ₂ (Kg)			NA
Applications :	Teaching, Demonstration & Testing of Electrical Energy Consumption of Household & Office Appliances. It can be used in Houses, Offices, Shops, Schools, Laboratories etc.			

Ordering Information : Model & Range



ಭಾರತ ಹವಿ ಎಲೆಕ್ಟ್ರಿಕಲ್ಸ್ ಲಿಮಿಟೆಡ್
भारत हेवी इलेक्ट्रिकल्स लिमिटेड
Bharat Heavy Electricals Ltd
(A Government of India Undertaking)
ELECTRONICS DIVISION
P.B. No 2606, MYSORE ROAD, BANGALORE - 560 026 INDIA
An ISO 9001, ISO 14001 & CHESAS 18001 COMPANY

PHONE : +918026998443
dthamaraju@bhel.edn.co.in

Date : 12th Dec 2012

To Whomsoever It May Concern

This is to certify that M/s Mecco Instruments Pvt Ltd, TTC Industrial Area, Mahape, Navi Mumbai- 400710 is registered with our unit of BHEL vide vendor code: M402467.

The supplier is registered for the supply of following material categories:

- Measuring Instruments such as Voltmeters, Ammeters, Wattmeters, Frequency Meters, PF Meters (Both Analog & Digital), and
- Indicators

Type of Registration: Permanent.

12/12/2013
(B.K. Diarmaraju)
Dy General Manager (Supplier Devpt Cell)

ಭಾರತ ಹವಿ ಎಲೆಕ್ಟ್ರಿಕಲ್ಸ್ ಲಿಮಿಟೆಡ್
ಭಾರತ ಹವಿ ಎಲೆಕ್ಟ್ರಿಕಲ್ಸ್ ಲಿಮಿಟೆಡ್
DTHAMARAJU E.K., Dy GENERAL MANAGER(SUPPLIER DEVPT CELL)
BHEL-EDN, MYSORE ROAD, BANGALORE - 560 026

Visit us at www.bhel.com, www.bhel.edn.com



VINAYAK TRANSMISSION PRODUCTS PVT. LTD.

O: 116/321, Unique Indl Estate, Prabhadevi, Mumbai - 25, INDIA T: 022 24220743 F: +91 22 24225155 E: info@vinayaktrans.com
F: W-276, MIDC, TTC, Rabale, Navi Mumbai - 400 701, INDIA T/F: +91 22 27607738 E: vtpl@mtnl.net.in

To,
M/s. Mecco Instruments Pvt. Ltd.
Plot No. 1, MIDC Electronic Zone,
TTC Industrial Area, Mahape, Navi Mumbai - 400 710
Tel. No. 022 - 27673300 Fax No. 022 - 27673310

Dear Sir,

Kind Attn : Mr. Kamal Goliya - C.E.O. /Mr. Haren Shah - Sr. Mkt. Executive

Sub MECO Make Digital Panel Meters & Frequency Meters in our Panel for MSEDCL - Infra Projects.

Project C & R Panel for MSEDCL - Infra Projects.

We have issued several purchase order to MECO Instruments Pvt. Ltd. Mahape, Navi Mumbai for MECO Make Digital Panel Meters & Frequency Meters for our C & R Panel for MSEDCL-Infra Projects.

Overall performance of MECO Make Digital Panel meters & Digital Frequency meters supplied to us are found satisfactory. We also appreciate M/s. MECO Instruments for extending timely delivery for our purchase order released time to time.

We look forward to have similar kind of service and support as and when required from MECO Team members in future.

This letter is issued as per request from M/s MECO Instruments Pvt. Ltd. as feedback from Customers.

Thanking You,
Yours Faithfully,

Vinayak Transmission Products Pvt. Ltd.

V.V. Karmalkar
Dy. General Manager
982085499

28 NOV 2015



Date: 16 November 2015

To,
Director
M/s. Mecco Instruments Pvt. Ltd.
Plot No. 1, MIDC Electronic Zone,
TTC Industrial Area, Mahape, Navi Mumbai - 400 710
Tel. No. 022 - 27673300 Fax No. 022 - 27673310

Dear Sir,

Sub Performance of MECO Make Analog / Digital Panel Meters

Please refer our several purchase order to MECO Instruments Pvt. Ltd. Mahape, Navi Mumbai for MECO Make Analog / Digital Panel Meters for our Panels.

Performance of MECO Make Analogue / Digital Panel Meters supplied to us against our several purchase order are satisfactory.

We appreciate Mr. Haren Shah - Senior Marketing Executive (Mobile : 09820093232 & Email harenvshah@mecoinst.com) & M/s. MECO Instruments for extending service and support as well as executing order with timely delivery as per our requirements.

We look forward to have similar kind of service and support as and when require from Mr. Haren Shah & MECO Team members in future also.

Thanking You,

Your Faithfully,

For VIVID ELECTROMECH PVT. LTD.
[Signature]
DIRECTOR

Mumbai Office :
F/A, Shanti Nagar, Industrial Estate,
Vakola, Santacruz (E),
Mumbai - 400 055.

Manufacturing Unit :
Vivid House, A-16A,
M.I.D.C. Kharane,
Navi Mumbai - 400 705.
Tel: 022 41025555

www.vividgroup.in

Bangalore Office :
202, Nustalga, Robertson Rd,
Fraser Town, Bangalore-560 005
Tel.: 080-40915303
080-41127496

16 DEC 2015



ANASAPATI EDUCATION SOCIETY'S
Anasapati
Chudaman Patil
College of
Engineering

Approved by AICTE New Delhi, Dept. of Management & Affiliated to the University of Mumbai.

Ref: ACPCE/04/2144/2015-16

Date: 04/12/2015

To,
Mr. Kamal Goliya - C.E.O.
M/s. Mecco Instruments Pvt. Ltd.
Plot No. 1, MIDC Electronic Zone,
TTC Industrial Area, Mahape, Navi Mumbai - 400 710

Sub: Performance of MECO Make Education Desk Type Moving Iron & Moving Coil Ammeters & Voltmeters & Digital Multimeters

Ref: Education Meters & Digital Multimeters for Diploma / Degree Students of our institute.

Dear Sir,

We are please to inform you that Performance of MECO Make Education Desk Meters & Digital Multimeters supplied to us against our several purchase orders are found working satisfactory.

The Education Meters & Test Instruments supplied to us by M/s. MECO Instruments are useful to our faculty for teaching students and also for our students for their several projects carried out in our college.

We thanks Mr. Haren Shah - Senior Marketing Executive for extending timely delivery for our purchase order as and when released.

We also appreciate M/s. MECO INSTRUMENTS PVT. LTD for allowing our students for industrial visit & Inplant Training at MECO- Mahape Work as per MSBTE norms.

We look forward to have similar kind of service and support from Mr. Haren Shah & MECO Team members in future also.

Thanking You.

Yours faithfully,

[Signature]
(Dr. D. G. Borse)
Principal.

Plot No. 17, Sector 4, Kharghar, Opp. Kharghar Fly. Station, Navi Mumbai - 410 210 • E-mail: principal@acpce.org
Website: www.acpce.org • Tel.: 2774 5722 / 85252102 / 85252103 • Telefax: 2774 5732

MECO®

SINCE 1962

Digital Panel Meters & Modules



Reliable, Long-Lasting and Affordable Instruments ...since 1962 !

www.mecoinst.com

An ISO 9001-2008 Certified Company

MECO INSTRUMENTS PRIVATE LTD.

NAVI MUMBAI

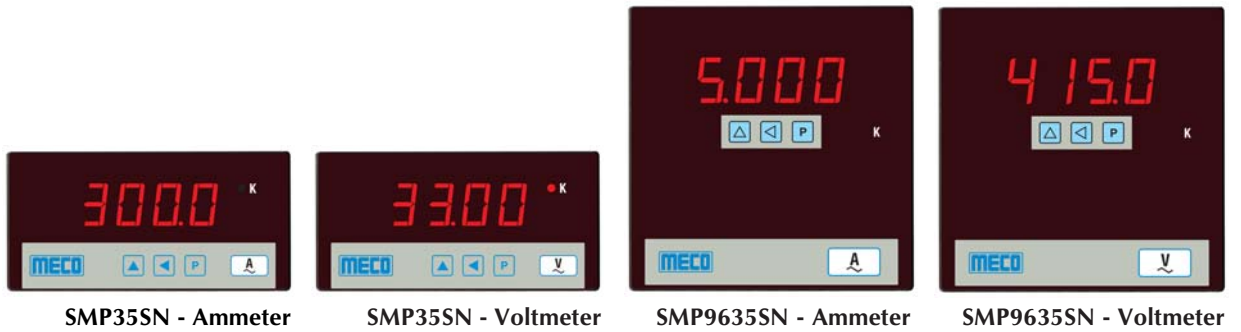

Features

- 1A / 5A Input in same Meter (User Selectable)
- High Accuracy Across the Entire Range
- 9999 Count High Resolution Display
- Dual Aux. 110V AC and 230V AC in same Meter
- User Programmable Display / CTP / PTR
- Auto Selection of Decimal Point
- Auto Indication of KV & KA
- Setup / Programming Protected by Password

Specifications

- **Measuring Method** TRMS using Microcontroller
- **Display Type** Red LED Super Bright Display
- **Maximum Display** 4 Digit / 9999 Counts
- **Overload Indication** - OL -
- **Underload Indication** - UL -
- **Resolution** 0.001 to 1 Count Depending on Range
- **Sampling Rate** 3 Samples / Second
- **Maximum Overload** Voltage : 1.2 times continuous
Current : 2 times continuous
- **Mounting Clamps** Sturdy, Derline (Engineering plastic)
- **VA Burden (Typical)** Auxiliary : <7VA
Voltage Input : <0.6VA
Current Input : <0.5VA
- **Frequency Response** 45 - 65Hz
- **Environmental Conditions** 0 to 55°C, <70% RH (Operation)
-10 to 70°C, <70% RH (Storage)
27°C ± 5°C (Calibration)
- **Dielectric Strength** 2.5 kV at 50Hz for 1 min. between Input - Auxiliary & Case - Terminals
- **Impulse Withstand** 3.5kV, 1.2 / 50 μs
- **Case / Housing Material** Black ABS, Dimension as per DIN 43700
- **Faceplate / Lens** Red Antiglare Faceplate with Annunciators
- **Connectors** Terminal Block : Thermoplastic (UL 94V-0) with Tin Plated Brass Terminals
- **Display Stability** Within ± 2 Digits

Model	Input AC	Range (any one only)	Programmable Display / CTP / PTR	Dual Aux. Supply	Accuracy	Digits (max.)	Display Digit Height
				110 and 230V AC	±(0.5% FSD + 2 dgts)	4	0.56"/14.2mm
SMP35SN	V	5 - 750V AC	1 - 9999	✓	✓	✓	✓
SMP9635SN	A	For 1A Range : 0.080 - 1.200A AC For 5A Range : 0.200 - 6.000A AC	1 - 9999 5 - 9999	✓	✓	✓	✓

Dimensions (mm)		
Model	SMP35SN	SMP9635SN
Front	48 x 96	96 x 96
Depth (Behind Bezel)	88	38
Panel Cut-Out	44 ^(+0.5, -0.0) x 92 ^(+0.8, -0.0)	92 ^(+0.8, -0.0) x 92 ^(+0.8, -0.0)

Ordering Information for Ammeter: Model
Ordering Information for Voltmeter: Model

Terminal Connection

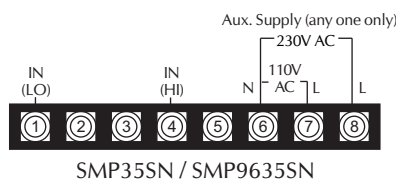



SMP4SN-5A

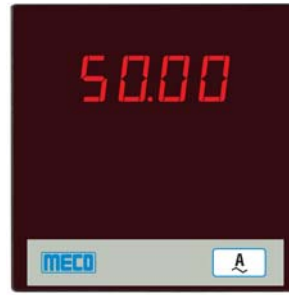

SMP964SN-5A

Features

- 5A AC Input
- High Accuracy Across the Entire Range
- 9999 Count High Resolution Display
- 230V AC Aux. Supply
- User Programmable C.T.Primary (CTP)
- Auto Selection of Decimal Point

Specifications

- | | |
|-----------------------------------------------------------------------------------------------------------------------------------------------------------------------------------------------------------------------------------------------------------------------------------------------------------------------------------------------------------------------------------------------------------------------------------------------------------------------------------------------------------------------------------------------------------------------------------------------------------------------------------------------------------------|--------------------------------------------------------------------------------------------------------------------------------------------------------------------------------------------------------------------------------------------------------------------------------------------------------------------------------------------------------------------------------------------------------------------------------------------------------------------------------------------------------------------------------------------------------------------------------|
| <ul style="list-style-type: none"> ● Measuring Method TRMS using Microcontroller ● Display Type Red LED Super Bright Display ● Maximum Display 4 Digit / 9999 Counts ● Resolution 0.001 to 1 count Depending on Range ● Sampling Rate 3 Samples / Second ● Maximum overload Current : 2 times continuous ● VA Burden (Typical) Aux. : < 7VA
Current Input : < 0.5VA ● Frequency Response 45 - 65 Hz ● Dielectric Strength 2.5kV at 50Hz for 1min. Between Input - Aux. & Case - Terminals | <ul style="list-style-type: none"> ● Environmental Conditions 0 to 55°C, < 70% RH (Operation)
-10 to 70°C, < 70% RH (Storage)
27°C ± 5°C (Calibration) ● Impulse Withstand 3.5kV, 1.2 / 50µ s ● Case / Housing Material Black ABS, Dimension as per DIN 43700 ● Faceplate / Lens Red Antiglare Faceplate with Annunciators ● Connectors Terminal Block : Thermoplastic (UL 94V - 0) with Tin plated Brass Terminals ● Display Stability Within ± 2 Digits |
|-----------------------------------------------------------------------------------------------------------------------------------------------------------------------------------------------------------------------------------------------------------------------------------------------------------------------------------------------------------------------------------------------------------------------------------------------------------------------------------------------------------------------------------------------------------------------------------------------------------------------------------------------------------------|--------------------------------------------------------------------------------------------------------------------------------------------------------------------------------------------------------------------------------------------------------------------------------------------------------------------------------------------------------------------------------------------------------------------------------------------------------------------------------------------------------------------------------------------------------------------------------|

Model	Input AC	Range	Aux. Supply	Accuracy	Digits (Max.)	Display Digit Height
SMP4SN - 5A	A	5A Range (0.050 - 6 AAC)	230V AC	± (0.5% FSD+2 dgts.)	4	0.56" / 14.2 mm
SMP964SN-5A						

User Programmable CTP Values

CT Primary Value				
0005	0080	0500	1300	5000
0010	0090	0600	1400	6000
0020	0100	0700	1500	7000
0025	0150	0800	1600	8000
0050	0200	0900	2000	9000
0060	0250	1000	2500	
0070	0300	1100	3000	
0075	0400	1200	4000	

Single Switch Operation

Press Switch to Change CTP

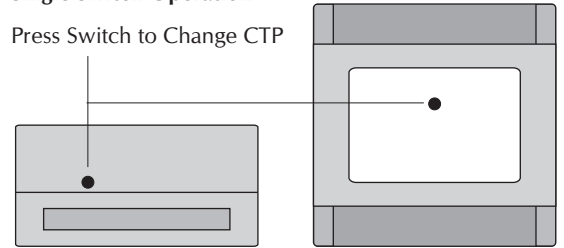

Back Side of Meter

Dimensions (mm)		
Model	SMP4SN - 5A	SMP964SN - 5A
Front	48 x 96	96 x 96
Depth (Behind Bezel)	88	38
Panel Cut-Out	44 ^(+0.5, -0.0) x 92 ^(+0.8, -0.0)	92 ^(+0.8, -0.0) x 92 ^(+0.8, -0.0)

Ordering Information : Model

Terminal Connection

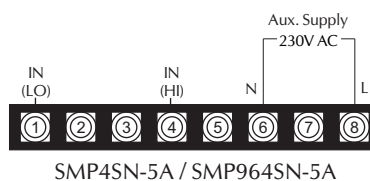



SMP35S



SMP9635S

Specifications

- | | | | |
|--------------------------------|-------------------------------------------------------------------------------------------------|----------------------------------|---------------------------------------------------------------------------------------------------------------------------|
| ● Measuring Method | Dual Slope A/D Conversion | ● Crest Factor | 4 (max.) TRMS accuracy specified for sine wave input |
| ● Sampling Rate | 2.5 Samples per Second | ● VA Burden (Typical) | Auxiliary (110 / 230V AC) : < 5VA
Auxiliary (SMPS) : < 2.5VA
Voltage : < 0.1VA
Current : < 0.5VA, < 0.2VA in 20A |
| ● Display Type | Red LED Super Bright Display | ● Dielectric Strength | 2.5 kV at 50Hz for 1 min. between Input - Auxiliary - Case - Terminals |
| ● Maximum Display | 1999 Counts | ● Case / Housing Material | DIN Black ABS, Dimension as per DIN 43700 |
| ● Resolution | 0.001 to 1 Count depending on range | ● Mounting Clamps | Sturdy, Moulded ABS with suitable Hardware |
| ● Polarity Indication | " - " is indicated for Negative Input | ● Connectors | Terminal Block : Thermoplastic (UL 94V-0) with Tin Plated Brass Terminals |
| ● Decimal Selection | Field Selectable | ● Display Stability | Within ± 2 Digits |
| ● Over Range Indication | " 1 " or " -1 " | | |
| ● Maximum Overload | Voltage : 1.2 times continuous
Current : 2 times continuous | | |
| ● Frequency Response | 40 - 400Hz | | |
| ● Faceplate / Lens | Red Antiglare Faceplate with Annunciators | | |
| ● Environment | Calibration : 27°C ± 5°C,
Operating : 0 to 50°C, RH < 70%
Storage : -10 to 60°C, RH < 70% | | |

Model	Input	Range	Auxiliary Power Supply (any one only)			Accuracy Class			Digits (max.)		Display Digit Height	
			110 / 230V AC	SMPS-LV 19-90V AC/DC	SMPS-HV 85-265V AC/DC	0.2	0.5	1	2	3½	0.56"/ 14.2mm	
SMP35S / SMP9635S	DC	mV	0 - 200mV	✓	✓	✓	✓	-	-	-	✓	✓
		V	0 - 2, 20, 200V	✓	✓	✓	✓	-	-	-	✓	✓
		V	0 - 1000V	✓	✓	✓	-	✓	-	-	✓	✓
		mA	0 - 2, 20, 200mA	✓	✓	✓	✓	-	-	-	✓	✓
		A	0 - 2, 5, 20A	✓	✓	✓	-	✓	-	-	✓	✓
		Zero Supp.	4-20mA or 1 - 5V	✓	✓	✓	✓	-	-	-	✓	✓
	Re-Scaleable	0 - 5V / 10V DC, 1 - 5V DC, 0 - 20mA DC, 0 - 50 / 60 / 75mV, 4 - 20mA (any one) to display 0.100 to 1600 in 64 steps. Please suffix these models with RS as SMP35SRS or SMP9635SRS	✓	✓	✓	-	✓	✓	-	✓	✓	
	AC	V	0 - 2, 20, 200, 750V	✓	✓	✓	-	✓	-	-	✓	✓
		A	0 - 2, 5A	✓	✓	✓	-	✓	-	-	✓	✓
		A	0 - 20A	✓	✓	✓	-	-	✓	-	✓	✓
Re-Scaleable		0 - 1A or 0-5A (any one) to display 0.100 to 1600 in 64 steps. Please suffix models with RS as SMP35SRS or SMP9635SRS	✓	✓	✓	-	✓	-	-	✓	✓	



SMP35ST



SMP9635ST



SMPTC, SMPTCS



SMP96TC, SMP96TCS

Model	Input	Range	Auxiliary Power Supply (any one only)			Accuracy Class	Digits (max.)		Display Digit Height
			110 / 230V AC	SMPS-LV 19-90V AC/DC	SMPS-HV 85-265V AC/DC		1	2	
SMP35ST / SMP9635ST	TRMS	V	0 - 2, 20, 200, 750V	✓	✓	✓	✓	-	✓
		A	0 - 2, 5A	✓	✓	✓	✓	-	✓
		A	0 - 20A	✓	✓	✓	✓	-	✓

Model	Input	Range	Auxiliary Power Supply (any one only)		Accuracy Class		Digits (max.)	Display Digit Height	
			110 / 230V AC	24 / 48 / 110 / 220V DC	1	2		0.56" / 14.2mm	0.8" / 20mm
SMPTC / SMP96TC	DC	TAP Position	4 - 20mA DC from Transducer to Display "01 for 4mA DC" and "02 to 99 for 20mA DC".		-	✓	✓	✓	✓

Dimensions (mm)				
Model	SMP35S / SMP35ST	SMPTC	SMP9635S / SMP9635ST	SMP96TC
Front	48 x 96	48 x 96	96 x 96	96 x 96
Depth (Behind Bezel)	88	135	90	135
Panel Cut-Out	44 ^(+0.5, -0.0) x 92 ^(+0.8, -0.0)	44 ^(+0.5, -0.0) x 92 ^(+0.8, -0.0)	92 ^(+0.8, -0.0) x 92 ^(+0.8, -0.0)	92 ^(+0.8, -0.0) x 92 ^(+0.8, -0.0)

Ordering Information: Model, Input Range, CTR / PTR (if any), Scale Display, Aux. Supply, Accuracy Class & Display Height

Terminal Connection

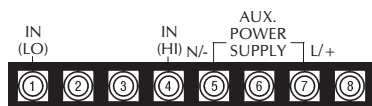

SMP35S / SMP9635S
SMP35ST / SMP9635ST

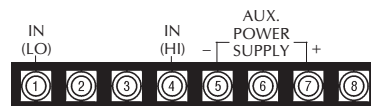

SMPTC / SMP96TC



SMP72x1445SN
Voltmeter - TRMS



SMP72x1445SN
Ammeter - TRMS



SMP72x1445SN
Voltmeter - DC



SMP72x1445SN
Ammeter - DC

Features

- User Programmable Display / CTP / PTR
- 99999 Counts High Resolution Display
- SMPS Power Supply
- High Accuracy Across the Entire Range

Specifications

- **Measurement Method** TRMS Using Microcontroller
- **Display Type** 1" / 25.4mm, Super Bright RED LED Display
- **Maximum Display** 5 Digit / 99999 Counts
- **Resolution** 0.0001 to 1 Count Depending on Range
- **Sampling Rate** 1 Second
- **Maximum Overload** Voltage : 1.2 times continuous
Current : 2 times continuous
- **Polarity Indication** "-VE" is indicated for Negative Input
- **Auxiliary Supply** 85 - 265VAC / DC (Standard)
or 19 - 90VAC / DC (Optional)
- **VA Burden (Typical)** Auxiliary : <2.5VA
Voltage Input : <0.2VA / Phase
Current Input : <0.2VA / Phase
- **Frequency Response** 45 - 55Hz

- Auto Selection of Decimal Point
- RS485 Port, 5KV Isolated with Modbus RTU Protocol (Optional)
- Power Master Software (Optional)

- **Dielectric Strength** 2.5KV at 50Hz for 1 min. Between Input - Aux. & Case - Terminals
- **Environmental Conditions** 0 to 55°C, <70% RH (Operation)
-10 to 60°C, <70% RH (Storage)
27°C ± 5°C (Calibration)
- **Case / Housing Material** Black ABS, Dimension as per DIN 43700
- **Face Plate / Lens** Red Antiglare Face Plate Annunciator
- **Connectors** Terminal Block Thermoplastic (UL94V-0) with Tin Plated Brass Terminals
- **Display Stability** Within ±2 Digits
- **Dimensions** Front : 72 x 144mm
Depth : 93mm
Panel Cut Out : 68^(+0.8, -0.0) x 138^(+0.8, -0.0)

Model	Input	Range	Auxiliary Power Supply		Accuracy Class		Digits (max.)	Digit Height
			SMPS-HV 85-265V AC/DC (Standard)	SMPS-LV 19-90V AC/DC (Optional)	0.5	1		
SMP 72x1445SN	DC	mV	0 - 200mV	✓	✓	✓	✓	✓
		V	0 - 200V	✓	✓	✓	✓	✓
		V	0 - 1000V	✓	✓	✓	✓	✓
		mA	0 - 200mA	✓	✓	✓	✓	✓
		A	0 - 2, 5A	✓	✓	✓	✓	✓
		Zero Supp.	4 - 20mA or 1 - 5V	✓	✓	✓	✓	✓
SMP 72x1445SN - TRMS	AC	V	0 - 200, 750V	✓	✓	✓	✓	✓
		A	0 - 2, 5A	✓	✓	✓	✓	✓

Ordering Information : Model, Input Range, CTR / PTR (if any), Scale Display, Auxiliary Supply, Accuracy Class & RS 485 Modbus Communication (Optional).

Terminal Connection

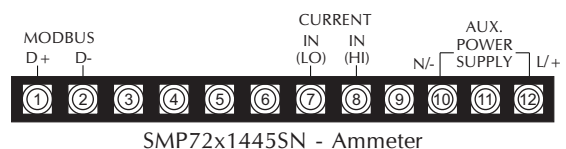
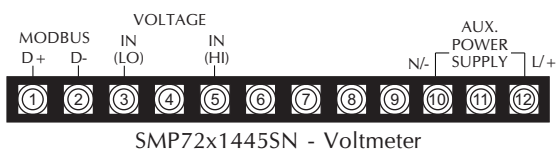



DWM72x144533 - TRMS
DWM72x144534 - TRMS



DVM72x144533 - TRMS
DVM72x144534 - TRMS



DVAM72x144533 - TRMS
DVAM72x144534 - TRMS



DPF72x144433 - TRMS
DPF72x144434 - TRMS

Features :

- TRMS Measurement
- 1"/25.4mm Digit Height Display
- 5 Digits 99999 Counts (Max.), Super Bright Display
- 3 Phase 3 Wire / 3 Phase 4 Wire System
- RS485 Port, 5KV Isolated with Modbus RTU Protocol (Optional)
- Power Master Software (Optional)
- CE Compliance with EN61010-1, EN61326-1
- Stable & Accurate
- SMPS Power Supply
- “ -VE “ is Displayed to Indicates Export of Power
- Auto Indication of K & M for Kilo & Mega Respectively
- Auto Selection of Decimal Point

Model	Parameter Measured (System)	Accuracy \pm (%FS)
DWM72x144533 - TRMS / DWM72x144534 - TRMS	3 Phase Active Power	$\pm 0.5\%$
DVM72x144533 - TRMS / DVM72x144534 - TRMS	3 Phase Reactive Power	$\pm 0.5\%$
DVAM72x144533 - TRMS / DVAM72x144534 - TRMS	3 Phase Apparent Power	$\pm 0.5\%$
DPF72x144433 - TRMS / DPF72x144434 - TRMS	3 Phase Power Factor	$\pm 1^\circ$ Electrical

Specifications

Auxillary Supply	85 - 265VAC / DC (Standard) 19 - 90VAC / DC (Optional)	System	3P2E3W / 3P3E4W
Voltage / Phase	51 - 300VAC (Max.) (PH-N) 23 - 138VAC (Max.) (PH-N)	Any One Only	Standard
Current / Phase	0.02A to 1.2A (Max.) 0.1A to 6A (Max.)	Any One Only	Installation Category
Frequency	45 - 55Hz		CAT II (IEC / EN61010-1)
Power Factor	0.300 Lag(L) - 1.000 - 0.300 Lead(C)		Pollution
VA Burden (Typical)			Degree 2 (IEC / EN61010-1)
Auxiliary	< 2.5VA		Environment
Voltage I/P	< 0.2VA / Phase		Calibration
Current I/P	< 0.2VA / Phase		27°C \pm 5°C
			Operating
			0 to 50°C, RH < 70%
			Storage
			-10 to 60°C, RH < 70%
			Terminal Block
			Screw Type
			Dielectric Strength
			2.5KV @ 50Hz for 1min.
			Insulation Resistance
			> 20MOhms at 500VDC

Dimensions (mm)

Front	72 x 144 mm
Depth	130 mm
Panel Cut-Out	68 ^(+0.8, -0.0) x 138 ^(+0.8, -0.0)
Case / Housing Material	Black ABS, Dimension as per DIN 43700
Mounting	Panel
Mounting Clamps	Sturdy, Moulded Derlin with Suitable Hardware
Terminals / Connectors	Terminal Block Thermo Plastic (UL94V-0) with Tin Plated Brass Terminals

Ordering Information : Model, Input Voltage, Input Current, Input Frequency, System 3P3E4W / 3P2E3W, CTR / PTR (if any), Auxiliary Supply & RS485 MODBUS Communication Port (Optional)

Terminal Connection

3 Phase 3 Element 4 Wire

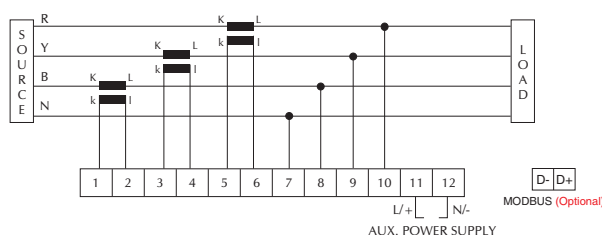

3 Phase 2 Element 3 Wire

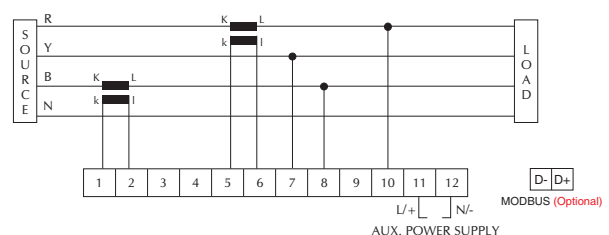



SMP45S, SMP45ST



SMP9645S
SMP9645ST



SMP72x14445, SMP72x14445S
SMP72x14445T, SMP72x14445ST

Specifications

- | | |
|-----------------------------------------------------------------------------------------------------------------------------------------------------------------------------------------------------------------------------------------------------------------------------------------------------------------------------------------------------------------------------------------------------------------------------------------------------------------------------------------------------------------------------------------------------------------------------------------------------------------------------------------------------------------------------------------------------------------------------------------------------------------------------------------------------------------------------------------------------------------------------------------|--------------------------------------------------------------------------------------------------------------------------------------------------------------------------------------------------------------------------------------------------------------------------------------------------------------------------------------------------------------------------------------------------------------------------------------------------------------------------------------------------------------------------------------------------------------------------------------------------------------------------------------------------------------------------------------------------------------------------------------------------------------------------------------------|
| <ul style="list-style-type: none"> ● Measuring Method Dual Slope A/D Conversion ● Sampling Rate 2.5 Samples per Second ● Display Type Red LED Super Bright Display ● Maximum Display 19999 Counts ● Resolution 0.0001 to 1 Count depending on the range ● Polarity Indication “ - ” is indicated for negative input ● Decimal Selection Field Selectable ● Over Range Indication "0000" blinking ● Maximum Overload Voltage : 1.2 times continuous
Current : 2 times continuous ● VA Burden (Typical) Auxiliary (110 / 230V AC) : < 5VA
Auxiliary (SMPS) : < 2.5VA
Voltage Input : < 0.1VA
Current Input : < 0.5VA, < 0.2VA in 20A ● Frequency Response 40 - 400Hz | <ul style="list-style-type: none"> ● Crest Factor 4 (max.) TRMS accuracy specified for sine wave input ● Faceplate / Lens Red Antiglare Faceplate with Annunciators ● Environment Calibration : 27°C ± 5°C,
Operating : 0 to 50°C, RH < 70%
Storage : -10 to 60°C, RH < 70% ● Dielectric Strength 2.5 kV at 50Hz for 1 min. between Input - Auxiliary - Case - Terminals ● Case / Housing Material DIN Black ABS, Dimension as per DIN 43700 ● Mounting Clamps Sturdy, Moulded ABS with suitable Hardware ● Connectors Terminal Block : Thermoplastic (UL 94V-0) with Tin Plated Brass Terminals ● Display Stability Within ± 2 Digits |
|-----------------------------------------------------------------------------------------------------------------------------------------------------------------------------------------------------------------------------------------------------------------------------------------------------------------------------------------------------------------------------------------------------------------------------------------------------------------------------------------------------------------------------------------------------------------------------------------------------------------------------------------------------------------------------------------------------------------------------------------------------------------------------------------------------------------------------------------------------------------------------------------|--------------------------------------------------------------------------------------------------------------------------------------------------------------------------------------------------------------------------------------------------------------------------------------------------------------------------------------------------------------------------------------------------------------------------------------------------------------------------------------------------------------------------------------------------------------------------------------------------------------------------------------------------------------------------------------------------------------------------------------------------------------------------------------------|

Model	Input	Range	Auxiliary Power Supply (any one only)			Accuracy Class		Digits (max.)	Display Digit Height	
			110 / 230V AC	SMPS-LV 19-90V AC/DC	SMPS-HV 85-265V AC/DC	0.5	1			
SMP45S / SMP9645S (Data Hold - Optional)	DC	mV	0 - 200mV	✓	✓	Under development, Please inquire with sales@mecoinst.com	✓	✓	✓	✓
		V	0 - 2, 20, 200V	✓	✓		✓	✓	✓	✓
		V	0 - 1000V	✓	✓		✓	✓	✓	✓
		mA	0 - 2, 20, 200mA	✓	✓		✓	✓	✓	✓
		A	0 - 2, 5A	✓	✓		✓	✓	✓	✓
		Zero Supp.	4-20mA or 1 - 5V	✓	✓		✓	✓	✓	✓
	AC	V	0 - 2, 20, 200, 750V	✓	✓		✓	✓	✓	✓
		A	0 - 2, 5A	✓	✓		✓	✓	✓	✓
SMP45ST / SMP9645ST	TRMS	V	0 - 2, 20, 200, 750V	✓	✓	-	✓	✓	✓	
		A	0 - 2, 5A	✓	✓	-	✓	✓	✓	

Dimensions (mm)					
Model	SMP45S / SMP45ST	SMP9645S / SMP9645ST	SMP72x14445 / SMP72x14445T	SMP14445 / SMP14445T	SMP96x28845
Front	48 x 96	96 x 96	72 x 144	144 x 144	96 x 288
Depth (Behind Bezel)	88	90	130 93 (SMP72x14445S)	59 72 (SMP14445S)	77
Panel Cut-Out	44(+0.5, -0.0) x 92(+0.8, -0.0)	92(+0.8, -0.0) x 92(+0.8, -0.0)	68(+0.8, -0.0) x 138(+0.8, -0.0)	138(+0.8, -0.0) x 138(+0.8, -0.0)	92(+0.8, -0.0) x 282(+0.8, -0.0)



SMP14445S, SMP14445ST



SMP14445, SMP14445T



SMP96x28845

Model	Input		Range	Auxiliary Power Supply (any one only)		Accuracy Class		Digits (max.)	Display Digit Height	
				110 / 230V AC	24 / 48 / 110 / 220V DC	0.5	1		1.0" / 25.4mm	2.3" / 58mm
SMP72x14445S/ (Data Hold - Optional), SMP72x14445/ SMP14445	DC	mV	0 - 200mV	✓	✓	✓	✓	✓	✓	-
		V	0 - 2, 20, 200V	✓	✓	✓	✓	✓	✓	-
		V	0 - 1000V	✓	✓	✓	✓	✓	✓	-
		mA	0 - 2, 20, 200mA	✓	✓	✓	✓	✓	✓	-
		A	0 - 2, 5A	✓	✓	✓	✓	✓	✓	-
		Zero Supp.	4-20mA or 1 - 5V	✓	✓	✓	✓	✓	✓	-
SMP72x14445T/ SMP72x14445ST/ SMP14445T	TRMS	V	0 - 2, 20, 200, 750V	✓	✓	-	✓	✓	✓	-
		A	0 - 2, 5A	✓	✓	-	✓	✓	✓	-
SMP96x28845S (Data Hold - Optional)	DC	mV	0 - 200mV	✓	SMPS-LV 19-90V AC/DC or SMPS-HV 85-265V AC/DC only	✓	✓	✓	-	✓
		V	0 - 2, 20, 200V	✓		✓	✓	✓	-	✓
		V	0 - 1000V	✓		✓	✓	✓	-	✓
		mA	0 - 2, 20, 200mA	✓		✓	✓	✓	-	✓
		A	0 - 2, 5A	✓		✓	✓	✓	-	✓
		Zero Supp.	4-20mA or 1 - 5V	✓		✓	✓	✓	-	✓
	AC	V	0 - 2, 20, 200, 750V	✓	✓	✓	✓	✓	-	✓
		A	0 - 2, 5A	✓	✓	✓	✓	✓	-	✓

Ordering Information: Model, Input Range, CTR / PTR (if any), Scale Display, Data Hold (Optional), Auxillary Supply, Accuracy Class & Display Height

Terminal Connection



SMP45S / SMP9645S /
SMP45ST / SMP9645ST



SMP72x14445 / SMP72x14445S / SMP72x14445ST
SMP72x14445T



SMP14445 / SMP14445S / SMP14445T / SMP14445ST

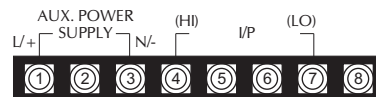

SMP96x28845



SMP9635SAS



SMP9635SVS33



SMP9635SVS34

Specifications

- | | |
|--------------------------------------------------------------------------------------------------------------------------------------------------------------------------------------------------------------------------------------------------------------------------------------------------------------------------------------------------------------------------------------------------------------------------------------------------------------------------------------------------------------------------------------------------------------------------------------------------------------------------------------------------------------------------------------------------------------------------------------------------------------------------------------------------------------------------------------------------------------------------------------------------------|-----------------------------------------------------------------------------------------------------------------------------------------------------------------------------------------------------------------------------------------------------------------------------------------------------------------------------------------------------------------------------------------------------------------------------------------------------------------------------------------------------------------------------------------------------------------------------------------------------------------------|
| <ul style="list-style-type: none"> ● Measuring Method Dual Slope A/D Conversion ● Sampling Rate 2.5 Samples per Second ● Display Type Red LED Super Bright Display ● Maximum Display 1999 Counts ● Resolution 0.001 to 1 Count depending on range ● Polarity Indication “ - ” is indicated for Negative Input ● Decimal Selection Field Selectable ● Over Range Indication “ 1 ” or “ -1 ” ● Maximum Overload Voltage : 1.2 times continuous
Current : 2 times continuous ● Frequency Response 40 - 400Hz ● Faceplate / Lens Red Antiglare Faceplate with Annunciators ● Environment Calibration : 27°C ± 5°C,
Operating : 0 to 50°C, RH < 70%
Storage : -10 to 60°C, RH < 70% | <ul style="list-style-type: none"> ● VA Burden (Typical) Auxiliary : < 2.5VA
Voltage : < 0.1VA
Current : < 0.5VA, < 0.2VA in 20A ● Dielectric Strength 2.5 kV at 50Hz for 1 min. between Input - Auxiliary - Case - Terminals ● Case / Housing Material DIN Black ABS, Dimension as per DIN 43700 ● Mounting Clamps Sturdy, Moulded ABS with suitable Hardware ● Connectors Terminal Block : Thermoplastic (UL 94V-0) with Tin Plated Brass Terminals ● Display Stability Within ± 2 Digits |
|--------------------------------------------------------------------------------------------------------------------------------------------------------------------------------------------------------------------------------------------------------------------------------------------------------------------------------------------------------------------------------------------------------------------------------------------------------------------------------------------------------------------------------------------------------------------------------------------------------------------------------------------------------------------------------------------------------------------------------------------------------------------------------------------------------------------------------------------------------------------------------------------------------|-----------------------------------------------------------------------------------------------------------------------------------------------------------------------------------------------------------------------------------------------------------------------------------------------------------------------------------------------------------------------------------------------------------------------------------------------------------------------------------------------------------------------------------------------------------------------------------------------------------------------|

Model	Input		Range	Aux. Power Supply (any one only)		Accuracy		Digits (max.)	Display Digit Height
				SMPS LV 19-90VAC/DC	SMPS HV 85-256VAC/DC	0.5	1		
SMP9635SAS	AC	A-3 Phase	1A or 5A (any one only)	✓	✓	✓	✓	✓	✓
SMP9635SVS33		V-3 Phase 3 Wire	63.5, 110, 230, 440 or 750V (any one only)	✓	✓	✓	✓	✓	✓
SMP9635SVS34		V-3 Phase 4 Wire	63.5, 110, 230, 440 or 750V (any one only)	✓	✓	✓	✓	✓	✓

Dimensions (mm)	
Model	SMP9635SAS / SMP9635SVS
Front	96 x 96
Depth (Behind Bezel)	90
Panel Cut-Out	92 ^(+0.8, -0.0) x 92 ^(+0.8, -0.0)

Ordering Information : Model, Input Range, CTR/PTR (if any), Scale Display, Aux. Supply, Accuracy Class & Display Height

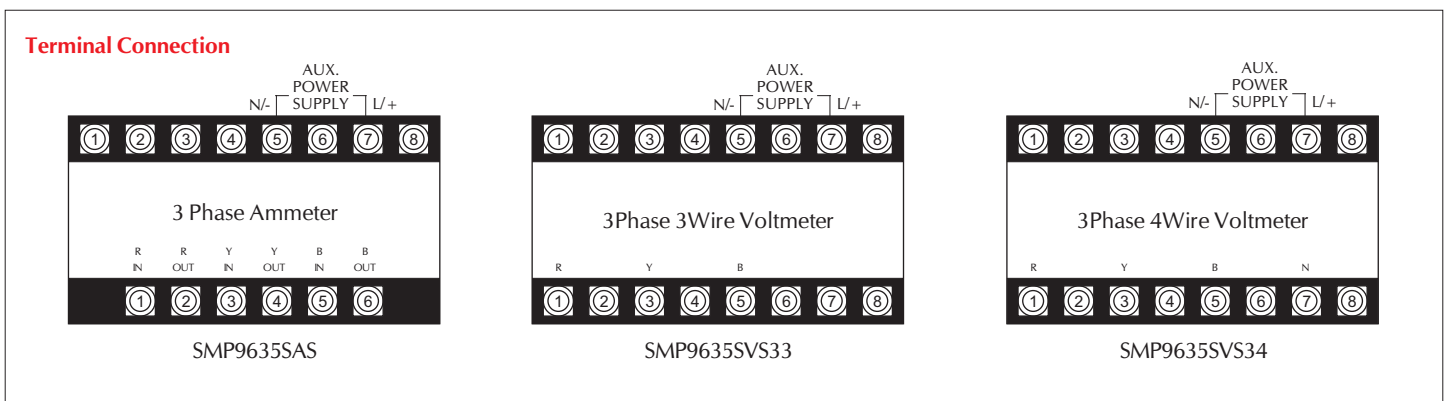

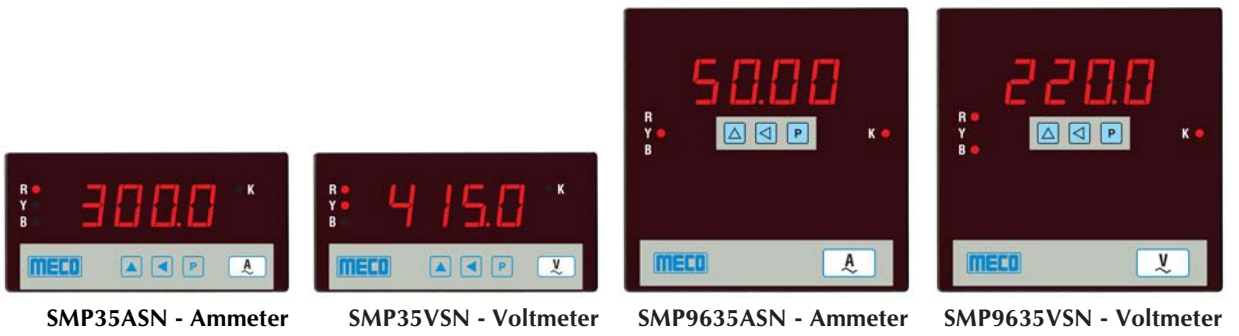

Features

- 1A / 5A Input in same Meter (User Selectable)
- High Accuracy Across the Entire Range
- 9999 Count High Resolution Display
- Aux. Power Supply : 85-265V AC / DC
- Auto / Manual Scroll Display (User Selectable)
- 3P3W / 3P4W (User Selectable)
- LED Indication for R, Y, B, RY, YB, BR
- User Programmable Display / CTP / PTR
- Auto Selection of Decimal Point
- Auto Indication of KV & KA
- Setup / Programming Protected by Password

Specifications

- **Measuring Method** TRMS using Microcontroller
- **Display Type** Red LED Super Bright Display
- **Maximum Display** 4 Digit / 9999 Counts
- **Overload / Underload** - OL - / - UL - Indication
- **Resolution** 0.001 to 1 Count Depending on Range
- **Sampling Rate** 3 Samples / Second
- **Maximum Overload** Voltage : 1.2 times continuous
Current : 2 times continuous
- **Faceplate / Lens** Red Antiglare Faceplate with Annunciators
- **Mounting Clamps** Sturdy, Derline (Engineering plastic)
- **VA Burden (Typical)** Auxiliary : < 2VA / Phase
Voltage Input : < 0.1VA / Phase
Current Input : < 0.5VA / Phase
- **Frequency Response** 45 - 65Hz
- **Environmental Conditions** 0 to 55°C, < 70% RH (Operation)
-10 to 70°C, < 70% RH (Storage)
27°C ± 5°C (Calibration)
- **Dielectric Strength** 2.5 kV at 50Hz for 1 min. between Input - Auxiliary & Case - Terminals
- **Impulse Withstand** 3.5kV, 1.2 / 50 μs
- **Case / Housing Material** Black ABS, Dimension as per DIN 43700
- **Connectors** Terminal Block : Thermoplastic (UL 94V-0) with Tin Plated Brass Terminals
- **Display Stability** Within ± 2 Digits

Model	Input AC	Range (any one only)	Programmable Display / CTP / PTR	Aux. Power Supply		Accuracy ±(0.5% FSD + 2 dgts)	Digits (max.)	Display Digit Height
				85-265V AC/ DC	19-90V AC/ DC			
SMP35VSN SMP9635VSN	V	51 - 300V AC (PH-N)	1 - 9999	✓	-	✓	✓	✓
SMP35ASN SMP9635ASN	A	For 1A Range : 0.080 - 1.200A AC For 5A Range : 0.200 - 6.000A AC	1 - 9999 5 - 9999	✓	-	✓	✓	✓

Dimensions (mm)		
Model	SMP35VSN / SMP35ASN	SMP9635VSN / SMP9635ASN
Front	48 x 96	96 x 96
Depth (Behind Bezel)	88	90
Panel Cut-Out	44 ^(+0.5, -0.0) x 92 ^(+0.8, -0.0)	92 ^(+0.8, -0.0) x 92 ^(+0.8, -0.0)

Ordering Information for Ammeter : Model

Ordering Information for Voltmeter : Model

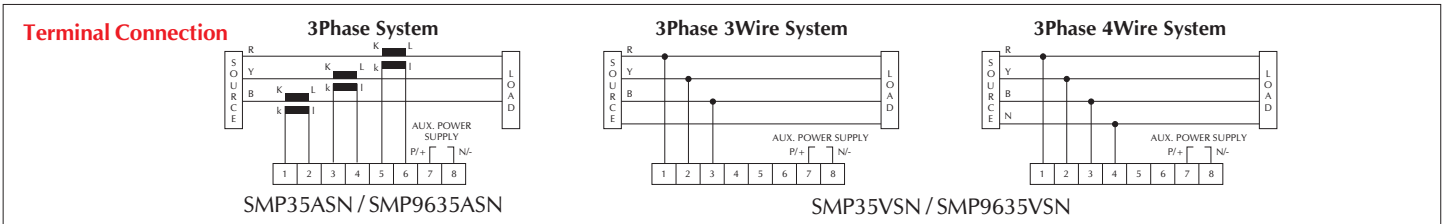



FDM963ASD



SMP9635SD



SMP14445D, SMP14445SD



FDM1444SAD, FDM1444SBD

Specifications

- **Measuring Method** Dual Slope A/D Conversion (Voltmeter)
Interval Measurement Method using Microcontroller (Frequency Meter)
- **Display Type** Red LED Super Bright Display
- **Maximum Display** 19999 Counts (Voltmeter)
9999 Counts (Frequency Meter)
- **Maximum Overload** Voltage : 1.2 times continuous
Current : 2 times continuous
- **Dielectric Strength** 2.5 kV at 50Hz for 1 min. between Input - Auxiliary Case - Terminals
- **Frequency Response** 40 - 400Hz (Voltmeter)
- **Faceplate / Lens** Red Antiglare Faceplate with Annunciators
- **Case / Housing Material** DIN Black ABS, Dimension as per DIN 43700
- **VA Burden (Typical) Per Display** Auxiliary : < 5VA
Voltage Input : < 0.1VA
Current Input : < 0.5VA
- **Environment** Calibration : 27°C ± 5°C,
Operating : 0 to 50°C, RH < 70%
Storage : -10 to 60°C, RH < 70%
- **Mounting Clamps** Sturdy, Moulded ABS with Hardware
- **Connectors** Terminal Block : Thermoplastic (UL 94V-0) with Tin Plated Brass Terminals
- **Display Stability** Within ± 2 Digits

Model	Input 1 Input 2		Range	Auxiliary Power Supply (any one only)				Accuracy Class		Digits (max.)		Display Digit Height	
				110 / 230V AC	24 / 48 / 110 / 220V DC	SMPS-LV 19-90V AC/DC	SMPS-HV 85-265V AC/DC	0.5	1	3½	4½	0.56" / 14.2mm	1.0" / 25.4mm
SMP14445D SMP14445SD	DC	Zero Supp.	4-20mA or 1 - 5V	✓	✓	-	-	✓	✓	-	✓	-	✓
	AC	V	0 - 20, 200, 750V	✓	✓	-	-	✓	✓	-	✓	-	✓
		I	0 - 2, 5A	✓	✓	-	-	✓	✓	-	✓	-	✓
SMP9635SD	AC	V	0 - 2, 20, 200, 750V	✓	-	✓	✓	✓	✓	✓	-	✓	-
		I	0 - 2, 5, 20A	✓	-	✓	✓	✓	✓	✓	-	✓	-
	DC	Zero Supp.	4-20mA or 1 - 5V	✓	-	✓	✓	✓	✓	✓	-	✓	-
		I	0 - 2, 5, 20A	✓	-	✓	✓	✓	✓	✓	-	✓	-

Model	Input 1 Input 2		Range	Auxiliary Power Supply (any one only)			Accuracy Class	Digits (max.)	Display Digit Height	
				110 / 230V AC	24 / 48 / 110 / 220V DC	Self Powered	±0.05 Hz	4 Digit	0.56" / 14.20mm	1.0" / 25.4mm
FDM1444AD	40 - 99.99Hz	Please Refer Note		✓	-	✓	✓	✓	-	✓
FDM1444BD				-	✓	-	✓	✓	-	✓
FDM963ASD				✓	-	✓	✓	✓	✓	-

Note : Input 20 - 500V AC For 110V AC or 230V AC or DC Aux. and For Self Powered Input variation is ± 20% of Aux.

Dimensions (mm)				
Model	SMP9635SD	FDM963ASD	SMP14445D SMP14445SD	FDM1444AD / FDM1444SAD FDM1444BD / FDM1444SBD
Front	96 x 96	96 x 96	144 x 144	144 x 144
Depth (Behind Bezel)	90	90	130 / 93	130 / 93
Panel Cut-Out	92 ^(+0.8, -0.0) x 92 ^(+0.8, -0.0)	92 ^(+0.8, -0.0) x 92 ^(+0.8, -0.0)	138 ^(+0.8, -0.0) x 138 ^(+0.8, -0.0)	138 ^(+0.8, -0.0) x 138 ^(+0.8, -0.0)

Ordering Information : Model, (Voltmeter/Ammeter) : Input Range, PTR/CTR (if any), Scale Display, Auxiliary Supply & Accuracy Class
(Frequency Meter) : Input Frequency Range, Input Voltage, PTR (if any), Auxiliary Supply & Accuracy Class

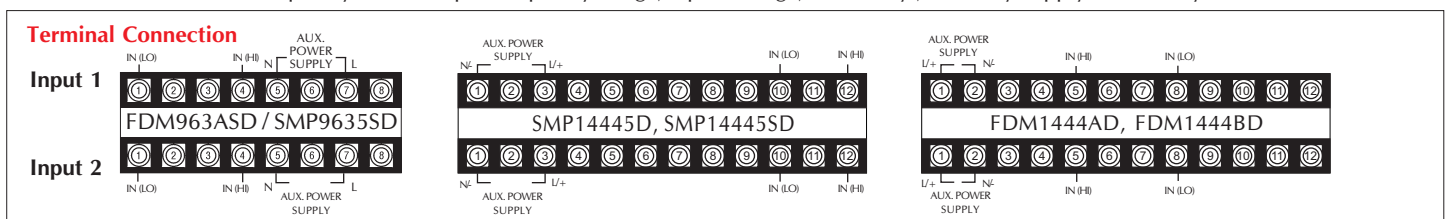



**FDM3AS / FDM72x1444SA
FDM5S / FDM72x1444SB**



RPM3AS



RPM963AS



**FDM963AS
FDM965S**



**FDM1444SA
FDM1444SB**

Specifications

- | | |
|---------------------------------------------------------------------------------------------------------------------------------------------------------------------------------------------------------------------------------------------------------------------------------------------------------------------------------------------------------------------------------------------------------------------------------------------------------------------------------------------------------------------------------------------------------------------------------------------------------------------------------------------------------------------------------------------------------------------------------|------------------------------------------------------------------------------------------------------------------------------------------------------------------------------------------------------------------------------------------------------------------------------------------------------------------------------------------------------------------------------------------------------------------------------------------------------------------------------------------------------------------------------------------------------------------------------------------------------------------------------------|
| <ul style="list-style-type: none"> ● Measuring Method Interval Measurement Method using Microcontroller ● Display Type Red LED (Standard) ● Maximum Display 9999 Counts for 4 Digit Meters
99999 Counts for 5 Digit Meters ● Resolution 0.01 to 0.1 for 4 Digit depending on range
0.001 to 0.1 for 5 Digit Depending on range
1 RPM for RPM Meter ● Decimal Selection Factory set ● Maximum Overload Voltage : 1.2 times continuous ● VA Burden (Typical) Auxiliary: < 4.5 VA
Voltage Input : < 0.5VA ● Faceplate / Lens Red Antiglare Faceplate with Annunciators | <ul style="list-style-type: none"> ● Environment Calibration : 27°C ± 5°C,
Operating : 0 to 50°C, RH < 70%
Storage : -10 to 60°C, RH < 70% ● Dielectric Strength 2.5 kV at 50 Hz for 1 min. between Input - Auxiliary - Case - Terminals
DIN Black ABS, Dimension as per DIN 43700 ● Case / Housing Material Sturdy, Moulded ABS with suitable Hardware ● Mounting Clamps Terminal Block : Thermoplastic (UL 94V-0) with Tin Plated Brass Terminals
Within ± 2 Digits ● Connectors ● Display Stability |
|---------------------------------------------------------------------------------------------------------------------------------------------------------------------------------------------------------------------------------------------------------------------------------------------------------------------------------------------------------------------------------------------------------------------------------------------------------------------------------------------------------------------------------------------------------------------------------------------------------------------------------------------------------------------------------------------------------------------------------|------------------------------------------------------------------------------------------------------------------------------------------------------------------------------------------------------------------------------------------------------------------------------------------------------------------------------------------------------------------------------------------------------------------------------------------------------------------------------------------------------------------------------------------------------------------------------------------------------------------------------------|

Model	Input		Auxiliary Power Supply (any one only)			Accuracy Class			Digits (max.)		Display Digit Height	
			110 / 230V AC	24 / 48 / 110 / 220V DC	Self Powered	±0.05 Hz	± 0.5 Hz	± 2.0 Hz	4 Digit	5 Digit	0.56" / 14.20mm	1.0" / 25.4mm
FDM3AS / FDM963AS	40 - 99.99Hz	20 - 500V AC For 110V AC or 230V AC Aux. and For Self Powered Input variation is ± 20% of Aux.	✓	-	✓	✓	-	-	✓	-	✓	-
	40 - 999.9Hz		✓	-	✓	-	✓	-	✓	-	✓	-
FDM5S / FDM965S	20 - 99.999Hz		✓	-	✓	✓	-	-	-	✓	✓	-
	20 - 999.99Hz		✓	-	✓	-	✓	-	-	✓	✓	-
	20 - 5000.0Hz		✓	-	✓	-	-	✓	-	✓	✓	-
FDM1444SA	40 - 99.99Hz		✓	-	✓	✓	-	-	✓	-	-	✓
FDM1444SB			-	✓	-	✓	-	-	✓	-	-	✓
FDM72x1444SA			✓	-	✓	✓	-	-	✓	-	-	✓
FDM72x1444SB		-	✓	-	✓	-	-	✓	-	-	✓	
RPM3AS / RPM963AS	300 - 1500RPM for 10 - 50Hz		✓	-	✓	✓	-	-	✓	-	✓	-

Dimensions (mm)				
Model	FDM3AS / FDM5S RPM3AS	FDM963AS / FDM965S RPM963AS	FDM72X1444SA FDM72X1444SB	FDM1444SA FDM1444SB
Front	48 x 96	96 x 96	72 x 144	144 x 144
Depth (Behind Bezel)	88	90	93	72
Panel Cut-Out	44(+0.5, -0.0) x 92(+0.8, -0.0)	92(+0.8, -0.0) x 92(+0.8, -0.0)	68(+0.8, -0.0) x 138(+0.8, -0.0)	138(+0.8, -0.0) x 138(+0.8, -0.0)

Ordering Information : Model, Input Frequency Range, RPM Range (for RPM Meter), Input Voltage, Auxiliary Supply, Accuracy Class, Digits & Display Digit Height

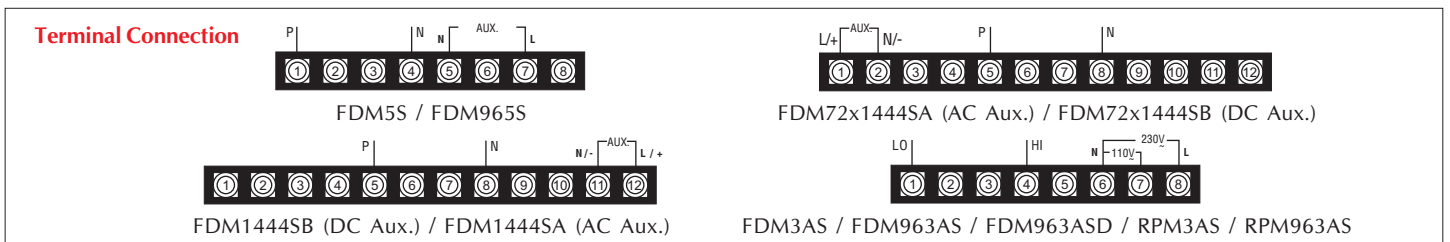



DPF11, DPF31



DPF9611S, DPF9631S



DPF72x14411, DPF72x14431



DPF14411, DPF14431

Specifications

- **Measuring Method** Cosine of Phase Shift between Voltage and Current
- **Sampling Rate** 2.5 Samples per Second
- **Display Type** Red LED (Standard)
- **Maximum Display** 4 Digits to indicate PF
- **Resolution** 0.001 PF
- **Under Current Indication** Error Code “.01 ” Blinking when current < 20% of Nominal is detected
- **Polarity Indication** L (Lagging/Inductive) or C (Leading/Capacitive)
- **Case / Housing Material** DIN Black ABS, Dimension as per DIN 43700
- **VA Burden (Typical)** Auxiliary : < 5 VA
Voltage Input : < 0.5VA / Phase
Current Input : < 0.5 VA / Phase
- **Maximum Overload** Voltage : 1.2 times continuous
Current : 2 times continuous
- **Environment** Calibration : 27°C ± 5°C,
Operating : 0 to 50°C, RH < 70%
Storage : -10 to 60°C, RH < 70%
- **Dielectric Strength** 2.5 kV at 50Hz for 1 min. between Case - Terminals
- **Mounting Clamps** Sturdy, Moulded ABS with Hardware
- **Connectors** Terminal Block : Thermoplastic (UL 94V-0) with Tin Plated Brass Terminals
- **Faceplate / Lens** Red Antiglare Faceplate with Annunciators
- **Display Stability** Within ± 2 Digits

Model	System (Phase, Element, Wire)	Input (Nominal)	Auxiliary Power Supply (any one only)			Accuracy Class		Digits (max.)	Display Digit Height	
			110 / 230V AC	24 / 48 / 110 / 220V DC	Self Powered	± 1 Degree	± 2 Degree		4 Digit	0.56" / 14.20mm
DPF11	1P 1E 2W	V for 1P1E2W = 110 / 230 V (P-N); V for 3P1E2W = 110 / 440 V (P-P); A = 1, 2 or 5A AC; Hz = 50Hz (V Range = ± 20% of Nominal A Range = 20 - 120% of Nominal) PF Range = 0.500 Lag (L) - 1 - 0.500 Lead (C)	-	-	✓	✓	✓	✓	✓	-
DPF31	3P 1E 2W (Balanced Load)		-	-	✓	✓	✓	✓	✓	-
DPF9611S	1P 1E 2W		✓	✓	✓	✓	✓	✓	✓	-
DPF9631S	3P 1E 2W (Balanced Load)		✓	✓	✓	✓	✓	✓	✓	-
DPF72x14411 DPF14411	1P 1E 2W		✓	✓	✓	✓	✓	✓	-	✓
DPF72x14431 DPF14431	3P 1E 2W (Balanced Load)		✓	✓	✓	✓	✓	✓	-	✓

Dimensions (mm)				
Model	DPF11 / DPF31	DPF9611S DPF9631S	DPF72X14411 DPF72X14431	DPF14411 DPF14431
Front	48 x 96	96 x 96	72 x 144	144 x 144
Depth (Behind Bezel)	135	90	130	59
Panel Cut-Out	44 ^(+0.5, -0.0) x 92 ^(+0.8, -0.0)	92 ^(+0.8, -0.0) x 92 ^(+0.8, -0.0)	68 ^(+0.8, -0.0) x 138 ^(+0.8, -0.0)	138 ^(+0.8, -0.0) x 138 ^(+0.8, -0.0)

Ordering Information : Model, Input Voltage, Input Current, Input Frequency, CTR / PTR (if any), Auxillary Supply, Accuracy Class & Display Digit Height

Terminal Connection
(Please refer page overleaf for other Models)

DPF9611S

DPF9631S

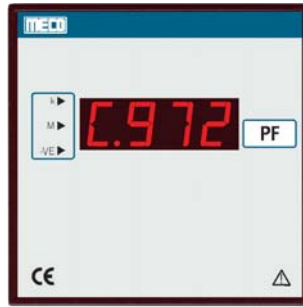

DPF9634S-TRMS

Specifications

- **Measuring Method** Cosine of Phase Shift between Voltage and Current
- **Display Type** Red LED (Standard)
- **Maximum Display** 3 Digits to indicate PF
- **Resolution** 0.001 PF
- **Polarity Indication** L (Lagging/Inductive) or C (Leading/Capacitive)
- **Case / Housing Material** Black ABS, Dimension as per DIN 43700
- **Maximum Overload** Voltage : 1.2 times continuous
Current : 1.2 times continuous
- **Dielectric Strength** 2.5 kV at 50Hz for 1 min. between Case - Terminals
- **Mounting Clamps** Sturdy, Moulded in Derline
- **Connectors** Detachable for easy replacement
- **Faceplate / Lens** Red Antiglare Faceplate with Annunciators
- **Display Stability** Within ± 2 Digits

Models	Parameters	System
DPF9634S-TRMS	PF-TRMS	3Phase 3Element 4Wire

Display	Display of 4 Digits, 0.56" / 14.2mm Digit Height
Auxiliary Supply (any one only)	230V AC $\pm 20\%$, 50Hz or 110V AC $\pm 20\%$, 50Hz
Input	
Voltage / Phase	50 - 300V (max.) (Phase to Neutral)
Current / Phase (any one only)	0.2A to 1.2 A (max.) or 1A to 6A (max.)
Frequency	45-55 Hz
Power Factor	0.300 Lag (L) - 1.000 - 0.300 Lead (C)
Accuracy	
Power Factor	$\pm 1^\circ$ Electrical
VA Burden (Typical)	
Auxiliary	< 5VA
Voltage Input	< 0.1VA / Phase
Current Input	< 0.5VA / Phase
Standard	
Installation Category	Cat II (IEC 1010-1)
Pollution	Degree 2 (IEC 1010-1)

Special Features	
CTR, PTR	Factory Set
Measurement	TRMS Four Quadrant Measurement
Environment	
Calibration	27°C $\pm 5^\circ$ C
Operating	0 to 50°C, RH < 70%
Storage	-10 to 60°C, RH < 70%
Terminals	Plug in type
Dimensions (mm)	
Front	96 x 96mm
Depth (Behind Bezel)	90mm
Panel Cut-Out	92 ^(+0.8, -0.0) x 92 ^(+0.8, -0.0)
Dielectric Strength	2.5kV at 50Hz for 1 min.
Insulation Resistance	> 20MOhms at 500V DC

Ordering Information : Model, Input Voltage, Input Current, Input Frequency, CTR / PTR (if any) & Auxillary Supply

Terminal Connection

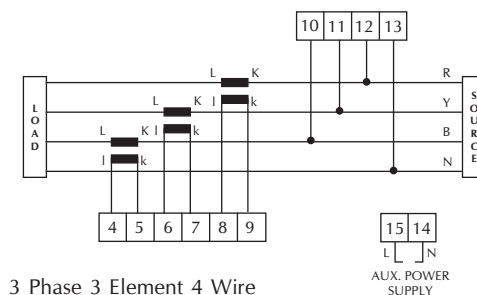



DWM72x144



DVM72x144



DWM96 / DWM144



DVM96 / DVM144

Specifications

- | | | | |
|-------------------------------------------------------------------------------------------------------------------------------------------------------------------------------------------------------------------------------------------------------------------------------------------------------------|---------------------------------------------------------------------------------------------------------------------------------------------------------------------------------------------------------------------------------------------------------------------------------------------------------------------------------------------------------------------------------------------------------------------------------------------------------------------------------------------------------------------------------------------------|-----------------------------------------------------------------------------------------------------------------------------------------------------------------------------------------------------------------------------------------------------------------------------------------------------------------------------|---------------------------------------------------------------------------------------------------------------------------------------------------------------------------------------------------------------------------------------------------------------------------------------------------------------------------------------------------------------------------------------------------------------------------------------------------------------------------------|
| <ul style="list-style-type: none"> ● Measuring Method ● Sampling Rate ● Display Type ● Resolution ● Maximum Overload ● VA Burden (Typical) ● Environment ● Over Range | <p>Multiplication of Pulse Width and Pulse Height
2.5 Samples per Second
Red LED (Standard)
0.001 to 1 depending on range for 3½ digit
0.0001 to 1 depending on range for 4½ digit
Voltage : 1.2 times continuous
Current : 2 times continuous
Auxiliary : < 5 VA
Voltage Input : < 0.5VA, < 5VA for R Phase in Self Powered
Current Input : < 0.5 VA / Phase
Calibration : 27°C ± 5°C,
Operating : 0 to 50°C, RH < 70%
Storage : -10 to 60°C, RH < 70%
" 1 " or " -1 "</p> | <ul style="list-style-type: none"> ● Dielectric Strength ● Polarity Indication ● Case / Housing Material ● Mounting Clamps ● Connectors ● Faceplate / Lens ● Note ● Display Stability | <p>2.5 kV at 50Hz for 1 min. between Case - Terminals
" - " is Displayed to indicate Export of Power
DIN Black ABS, Dimension as per DIN 43700
Sturdy, Moulded ABS with Hardware For 96x96mm (Detachable Connectors) For 72x144 & 144x144mm (Terminal Block) of Thermoplastic (UL 94V-0) with Tin Plated Brass Terminals
Red Antiglare Faceplate with Annunciators Digital Watt / Var Meters with External Transducer Against Inquiry Within ± 2 Digits</p> |
|-------------------------------------------------------------------------------------------------------------------------------------------------------------------------------------------------------------------------------------------------------------------------------------------------------------|---------------------------------------------------------------------------------------------------------------------------------------------------------------------------------------------------------------------------------------------------------------------------------------------------------------------------------------------------------------------------------------------------------------------------------------------------------------------------------------------------------------------------------------------------|-----------------------------------------------------------------------------------------------------------------------------------------------------------------------------------------------------------------------------------------------------------------------------------------------------------------------------|---------------------------------------------------------------------------------------------------------------------------------------------------------------------------------------------------------------------------------------------------------------------------------------------------------------------------------------------------------------------------------------------------------------------------------------------------------------------------------|

Model	Input (Nominal) A = 1, 2 or 5A AC PF 0.2 Lag - 1 - 0.2 Lead Hz = 50Hz		Auxiliary Power Supply (any one only)			Accuracy Class		Digits (max.)		Bi Directional		Display Digit Height	
			110/ 230V AC	24/48/ 110/220V DC	Self Powered	0.5	1.0	3½	4½	Input	Display	0.56" / 14.2mm	1.0" / 25.4mm
DWM963511 DVM963511	1P 1E 2W	V Range = ± 20% of Nominal; A Range = 20 - 120% of Nominal For 1P1E2W : 63.5 / 110 / 230 V (P-N); For 3P1E2W : 110 / 440 V (P-P); For 3P2E3W / 3P3E4W : 110 / 440 V (P-P)	✓	-	✓	✓	✓	✓	-	✓	✓	✓	-
DWM964511 DVM964511			✓	-	✓	✓	✓	-	✓	✓	✓	✓	-
DWM963531 DVM963531			3P 1E 2W (Balanced Load)	✓	-	✓	✓	✓	✓	-	✓	✓	✓
DWM964531 DVM964531	✓			-	✓	✓	✓	-	✓	✓	✓	✓	-
DWM963533 DVM963533	3P 2E 3W (Balanced & Unbalanced Load)		✓	-	✓	✓	✓	✓	-	✓	✓	✓	-
DWM964533 DVM964533			✓	-	✓	✓	✓	-	✓	✓	✓	✓	-
DWM963534 DVM963534	3P 3E 4W (Balanced & Unbalanced Load)		-	-	✓	✓	✓	✓	-	✓	✓	✓	-
DWM964534 DVM964534			-	-	✓	✓	✓	-	✓	✓	✓	✓	-
DWM1444511 DVM1444511	1P 1E 2W		✓	✓	✓	✓	✓	-	✓	✓	✓	-	✓
DWM1444531 DVM1444531	3P 1E 2W (Balanced Load)		✓	✓	✓	✓	✓	-	✓	✓	✓	-	✓
DWM1444533 DVM1444533	3P 2E 3W (Bal. & Unbal. Load)		✓	✓	✓	✓	✓	-	✓	✓	✓	-	✓
DWM1444534 DVM1444534	3P 3E 4W (Bal. & Unbal. Load)		✓	✓	✓	✓	✓	-	✓	✓	✓	-	✓
DWM72x1444511 DVM72x1444511	1P 1E 2W		✓	✓	✓	✓	✓	-	✓	✓	✓	-	✓
DWM72x1444531 DVM72x1444531	3P 1E 2W (Balanced Load)		✓	✓	✓	✓	✓	-	✓	✓	✓	-	✓
DWM72x1444533 DVM72x1444533	3P 2E 3W (Bal. & Unbal. Load)		✓	✓	✓	✓	✓	-	✓	✓	✓	-	✓
DWM72x1444534 DVM72x1444534	3P 3E 4W (Bal. & Unbal. Load)	✓	✓	✓	✓	✓	-	✓	✓	✓	-	✓	

Dimensions (mm)			
Model	DWM9635 / DWM9645 DVM9635 / DVM9645	DWM72x14445 DVM72x14445	DWM14445 DVM14445
Front	96 x 96	72 x 144	144 x 144
Depth (Behind Bezel)	135	130	59
Panel Cut-Out	92 ^(+0.8, -0.0) x 92 ^(+0.8, -0.0)	68 ^(+0.8, -0.0) x 138 ^(+0.8, -0.0)	138 ^(+0.8, -0.0) x 138 ^(+0.8, -0.0)

Ordering Information: Model, Input Voltage, Input Current, Input Frequency, CTR / PTR (if any), Scale Display, Auxillary Supply, Accuracy Class, Digits, Uni or Bi-Directional Input & Display Digit Height

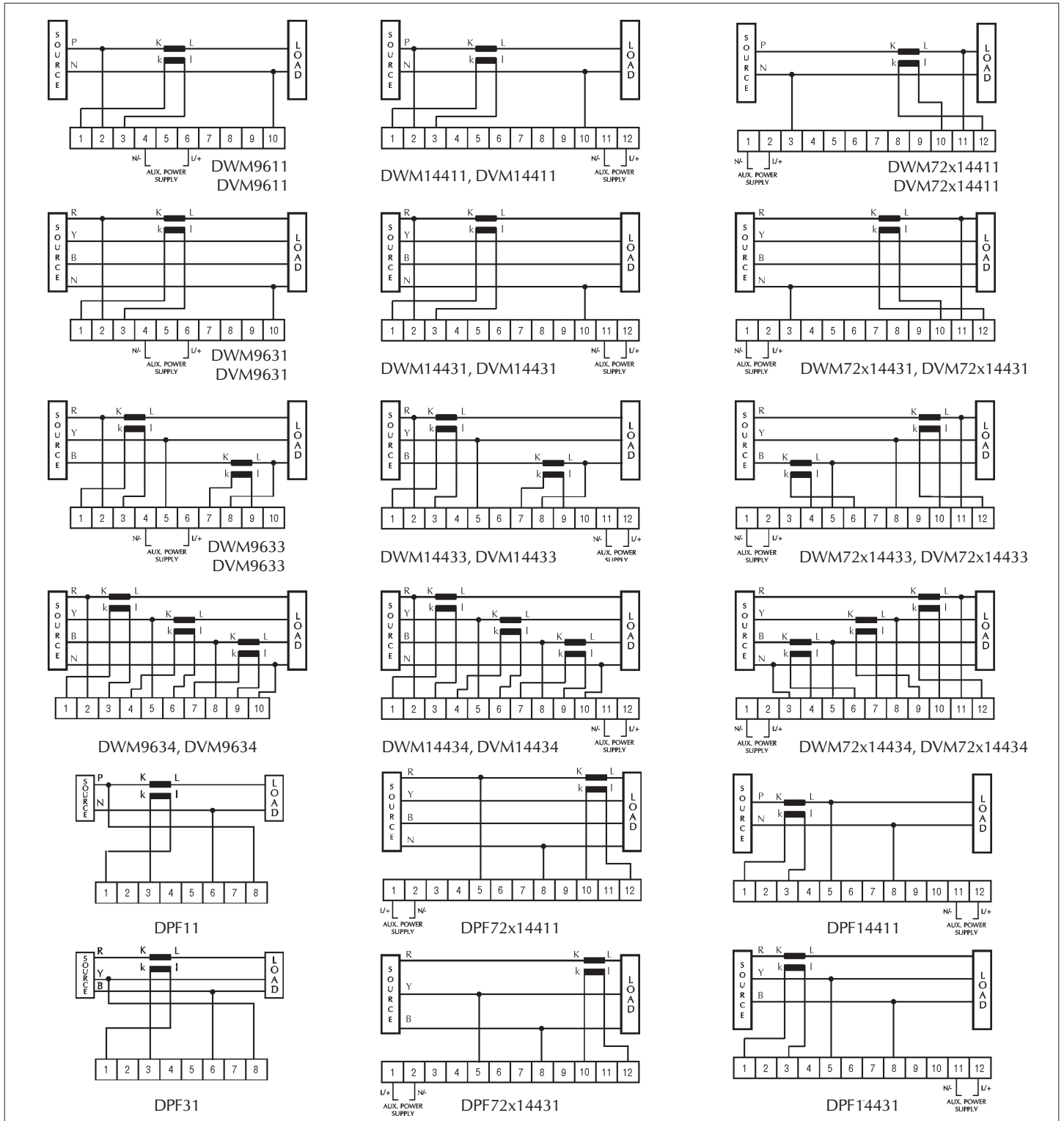

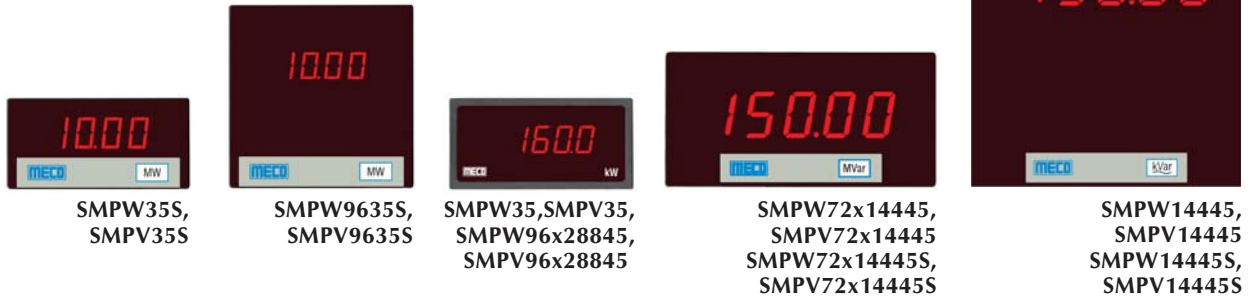

Specifications

MECO 1-Phase & 3-Phase Digital Watt / Var Meters (with External Transducer) are available in Sizes 48 x 96 / 96 x 96 / 72 x 144, 144 x 144mm, 96 x 288mm etc. with choice of AC / DC Aux. Supply and Display of Digit Height 0.56 / 0.8 / 1/2.3 inches. For detailed specifications, please refer catalog of Digital Panel Meters and respective pages of DIN Transducers. Below are listed some of the more popular Models. However several other types of V, A, W, Var, PF, Hz etc. meters with External Transducers are also available. For more details please refer to our sales@mecoinst.com

Display / Digits (max.)		3½ Digits, 1999 Counts				4½ Digits, 19999 Counts		
Display Height		14.2mm / 0.56"		20mm / 0.8" (Optional)		25.4mm / 1"		58mm / 2.3"
Type	System	48 x 96mm	96 x 96mm	48 x 96mm	96 x 96mm	72 x 144mm	144 x 144mm	96 x 288mm
Watt Meter	1P1E2W	SMPW3511S	SMPW963511S	SMPW3511	SMPW963511	SMPW72x1444511/S	SMPW1444511/S	SMPW96x2884511
	3P1E2W	SMPW3531S	SMPW963531S	SMPW3531	SMPW963531	SMPW72x1444531/S	SMPW1444531/S	SMPW96x2884531
	3P2E3W	SMPW3533S	SMPW963533S	SMPW3533	SMPW963533	SMPW72x1444533/S	SMPW1444533/S	SMPW96x2884533
	3P3E4W	SMPW3534S	SMPW963534S	SMPW3534	SMPW963534	SMPW72x1444534/S	SMPW1444534/S	SMPW96x2884534
Var Meter	1P1E2W	SMPV3511S	SMPV963511S	SMPV3511	SMPV963511	SMPV72x1444511/S	SMPV1444511/S	SMPV96x2884511
	3P1E2W	SMPV3531S	SMPV963531S	SMPV3531	SMPV963531	SMPV72x1444531/S	SMPV1444531/S	SMPV96x2884531
	3P2E3W	SMPV3533S	SMPV963533S	SMPV3533	SMPV963533	SMPV72x1444533/S	SMPV1444533/S	SMPV96x2884533
	3P3E4W	SMPV3534S	SMPV963534S	SMPV3534	SMPV963534	SMPV72x1444534/S	SMPV1444534/S	SMPV96x2884534
V (Any One)	Nominal Input	For 1P1E2W : 63.5 / 230 V (P-N); For 3P1E2W : 110 / 440 V (P-P); For 3P2E3W / 3P3E4W : 110 / 440 V (P-P)						
	Range	0 - 120% of Nominal						
A (Any One)	Nominal Input	1, 2, or 5A AC (also 10A AC for 1 Phase)						
	Range	0 - 120% of Nominal						
Hz		Standard : 50Hz, Optional : 60Hz						
PF		Standard Range : 0.2 Lag - 1 - 0.2 Lead						
Auxiliary Power Supply		48 x 96mm, 96 x 96mm, 96 x 288mm 85-265V AC/DC or 19-90V AC/DC		72 x 144mm & 144 x 144mm 48 x 96mm & 96 x 96mm 920mm/0.8" Display) Standard : 230V AC ± 10%, Optional : 63.5/110/440V AC ± 10%, 24/48/110/220V DC ± 10%			72x14445S /144x144S SMPS LV 19-90V AC/DC	
Accuracy (Calibrated at 27°C ± 5°C)		± (0.5% of Full Scale + 2 Digits)						

Ordering Information : Model, Input Voltage, Input Current, Input Frequency, CTR / PTR (if any), Scale Display, Auxillary Supply, Accuracy Class, Digits, Uni or Bi Directional & Display Digit Height.

Dimensions (mm)						
Model	SMPW14445 / S	SMPW9635	SMPW35	SMPW35S	SMPW72x144 / S	SMPW96x288
Front	144 x 144	96 x 96	48 x 96	48 x 96	72 x 144	96 x 288
Depth (Behind Bezel)	59 / 72	135	135	88	93 / 130	77
Panel Cut-Out	138 ^(+0.8, -0.0) x 138 ^(+0.8, -0.0)	92 ^(+0.8, -0.0) x 92 ^(+0.8, -0.0)	44 ^(+0.5, -0.0) x 92 ^(+0.8, -0.0)	44 ^(+0.5, -0.0) x 92 ^(+0.8, -0.0)	68 ^(+0.8, -0.0) x 138 ^(+0.8, -0.0)	92 ^(+0.8, -0.0) x 282 ^(+0.8, -0.0)
External Transducer (approx.)	As per DIN Series Transducers					



SM35MS

Specifications

- **Measuring Method** 3 ½ Digit - Dual Slope A/D Conversion
- **Sampling Rate** 2.5 Samples per Second
- **Display Type** 14.2 mm / 0.56" Digit Height Red LED
- **Maximum Display** 1999 Counts
- **Resolution** 0.001 to 1 Counts depending on the Range
- **Polarity Indication** " - " is Indicated for Negative Input
- **Decimal Selection** Field Selectable
- **Over Range Indication** " 1 " or " -1 "
- **Maximum Overload** Voltage : 1.2 times continuous
Current : 2 times continuous
- **VA Burden (Typical)** Auxiliary : < 1VA
Voltage : < 0.1VA, Current : < 0.25VA
- **Environment** Calibration : 27°C ± 5°C,
Operating : 0 to 50°C, RH < 70%
Storage : -10 to 60°C, RH < 70%
- **Mounting** Flush Mounting
- **Connectors** Header Pins on the PCB
- **Faceplate** Red Antiglare Lens - LED
- **Display Stability** Within ± 2 Digits

Display / Digits (max.)		3½ Digits, 1999 Counts LED
Ranges	Models	SM35MS
DC	mV	0 - 200 mV
	V	0 - 2, 20, 200 V
	µA	0 - 200 µA
	mA	0 - 2, 20, 200 mA
Auxiliary Power Supply		Standard : 5VDC ± 10% Note : IN-LO Signal & Supply Ground may be Connected Commonly
Accuracy (Specified at 27 ± 5°C)	V DC	± 0.5% of Full Scale
	A DC	
Dimensions (mm)	Front	79 x 42
	Depth (Behind Bezel)	24
	Panel Cut-Out	76.5 (+0.5, -0.0) x 39.5 (+0.5, -0.0)
	Drawing	

Ordering Information : Model, Input Range & Scale Display

Terminal Connection

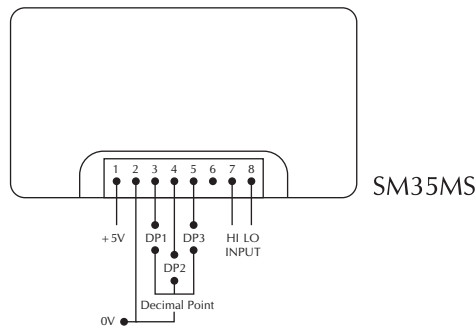

- Short Pin No.2 to Display Corresponding Decimal Point

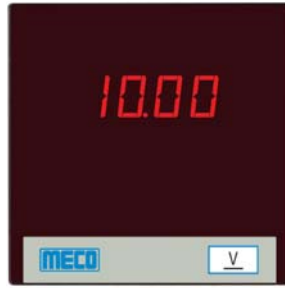

SM9635SD



SM35SD

Specifications

- **Measuring Method** Dual Slope A/D Conversion
- **Sampling Rate** 2.5 Samples per Second
- **Display Type** 14.2mm/0.56" Digit Height, Red LED (Standard)
- **Maximum Display** 1999 Counts for 3½ Digit Meters
- **Resolution** 0.001 to 1 Count for 3½ depending on the Range
- **Polarity Indication** " - " is indicated for Negative Input
- **Decimal Selection** Field Selectable
- **Over Range Indication** " 1 " or " -1 " for 3½ Digit Meters
- **Maximum Overload** Voltage : 1.2 times continuous
Current : 2 times continuous
- **Environment** Calibration : 27°C ± 5°C,
Operating : 0 to 50°C, RH < 70%
Storage : -10 to 60°C, RH < 70%
- **VA Burden (Typical)** Auxiliary : < 1.0VA
Voltage Input : < 0.1VA,
Current Input : < 0.5VA
- **Faceplate / Lens** Red Antiglare Faceplate with Annunciators
- **Dielectric Strength** 2.5 kV at 50Hz for 1 min. between Case - Terminals
- **Case / Housing Material** DIN Black ABS, Dimension as per DIN 43700
- **Mounting Clamps** Sturdy, Moulded ABS with suitable Hardware
- **Connectors** Terminal Block : Thermoplastic (UL 94V-0) with Tin Plated Brass Terminals
- **Display Stability** Within ± 2 Digits

Display / Digits (max.)		3½ Digits, 1999 Counts	
Digit Height		14.2mm/0.56"	
Ranges	Models	SM9635SD	SM35SD
DC	mV	0 - 200 mV	
	V	0 - 2, 20, 200, 1000 V	
	µA	0 - 200 µA	
	mA	0 - 2, 20, 200 mA	
	A	0 - 2, 5, 20 A	
	Zero Suppressed	4 - 20 mA or 1 - 5 V	
Auxiliary Power Supply		Standard : 5VDC ± 10%	
Accuracy (Specified at 27 ± 5°C) ± (%rdg + dgt)	V DC	(0.1 + 2)	
	A DC	(0.2 + 2) in all ranges except (0.3 + 2) in 2 A & 5 A (0.5 + 2) in 20 A	
Dimensions (mm)	Front	96 x 96	48 x 96
	Depth (Behind Bezel)	90	88
	Panel Cut-Out	92 (+0.8, -0.0) x 92 (+0.8, -0.0)	44 (+0.5, -0.0) x 92 (+0.8, -0.0)

Ordering Information : Model, Input Range & Scale Display

Terminal Connection

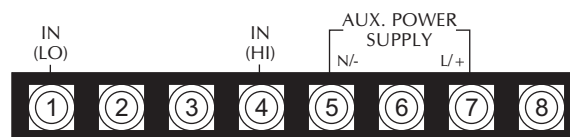

SM9635SD / SM35SD



Specifications

- **Measuring Method** 3½ Digit-Dual Slope A/D Conversion
4½ Digit-Successive Integration A/D Conversion
- **Sampling Rate** 2.5 Samples per Second
- **Display Type** 12.4 mm/0.48" Digit Height LCD for Gm035, DH035, GM035-BL (with Backlight)
11.0 mm/0.43" Digit Height LCD for Gm045
14.2 mm/0.56" Digit Height Red LED for GM135
- **Maximum Display** 1999 counts for 3½ Digit Meters
19999 counts for 4½ Digit Meters
- **Resolution** 0.001 to 1 count for 3½ depending on the range
0.0001 to 1 count for 4½ depending on the range
" - " is indicated for negative input
- **Polarity Indication**
- **Decimal Selection** Field Selectable
- **Over Range Ind.** " 1 " or " -1 "
- **Display Stability** Within ± 2 Digits
- **Maximum Overload** Voltage : 1.2 times continuous
Current : 2 times continuous
- **Low Batt. Indication** "LO BAT" in LCD Modules
- **External Start Hold** Provided in Models DH035 and Gm045
- **VA Burden (Typical)** Auxiliary : < 20mVA (LCD) & < 1VA (LED)
Voltage : < 0.1VA, Current : < 0.25VA
- **Environment** Calibration : 27°C ± 5°C,
Operating : 0 to 50°C, RH < 70%
Storage : -10 to 60°C, RH < 70%
- **Mounting Bezel** Elegant Black ABS Bezel with 4 fixing screws and necessary hardware
- **Connectors** PCB Edge Connector (Optional)
- **Faceplate** Red Antiglare Lens - LED
LCD Glass - LCD

Display / Digits (max.)		3½ Digits, 1999 Counts			4½ Digits, 19999 Counts
Ranges	Models	GM035-BL	GM035/DH035	GM135	GM045
DC	mV V µA mA			0 - 200 mV 0 - 2, 20, 200 V 0 - 200 µA 0 - 2, 20, 200 mA	
Auxiliary Power Supply		Standard : 9VDC ± 10% for GM035, GM035-BL, DH035 and GM045, 5VDC ± 10% for GM135 Note : Power Supply must be Isolated. Supply Ground must not be connected to IN-LO Signal. Please ensure when a shunt is used, it must be connected on Ground / Common side of the load and not on the Supply side.			
Accuracy (Specified at 27 ± 5°C) ± (%rdg + dgt)	V DC A DC		(0.1 + 2) (0.2 + 2)		(0.05 + 2)
Dimensions (mm)	Front	70.5 x 46			
	Depth (Behind Panel)	21			
	Panel Cut-Out	66.5 (+0.5, -0.0) x 28.5 (+0.5, -0.0)			
	Drawing				

Ordering Information: Model, Input Range & Scale Display

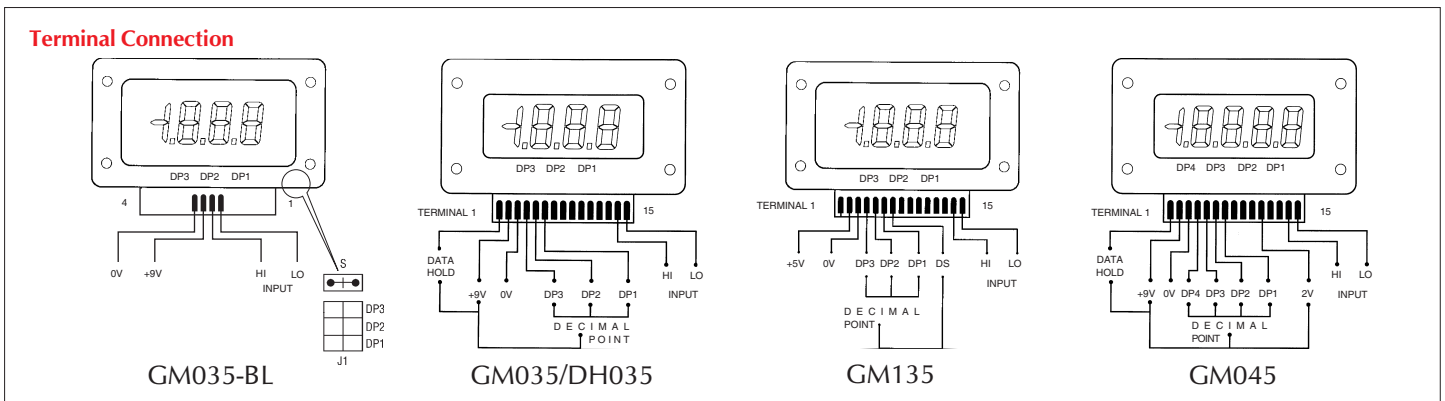

Note: External Start Hold - Provided for GM045 and DH035



LC035



LC135

Specifications

- **Measuring Method** 3 ½ Digit - Dual Slope A/D Conversion
- **Sampling Rate** 2.5 Samples per Second
- **Display Type** 12.4 mm/0.48" Digit Height LCD for LC035
14.2 mm/0.56" Digit Height Red LED for LC135
- **Maximum Display** 1999 Counts
- **Resolution** 0.001 to 1 Counts depending on the Range
- **Polarity Indication** " - " is Indicated for Negative Input
- **Decimal Selection** Field Selectable
- **Over Range Indication** " 1 " or " -1 "
- **Maximum Overload** Voltage : 1.2 times continuous
Current : 2 times continuous

- **VA Burden (Typical)** Auxiliary : < 20mVA (LCD) & < 1VA (LED)
Voltage : < 0.1VA, Current : < 0.25VA
- **Environment** Calibration : 27°C ± 5°C,
Operating : 0 to 50°C, RH < 70%
Storage : -10 to 60°C, RH < 70%
- **Mounting Bezel** Elegant ABS Bezel with 2 fixing screws and necessary hardware
- **Connectors** Header Pins on the PCB
- **Faceplate** Red Antiglare Lens - LED
LCD Glass - LCD
- **Display Stability** Within ± 2 Digits

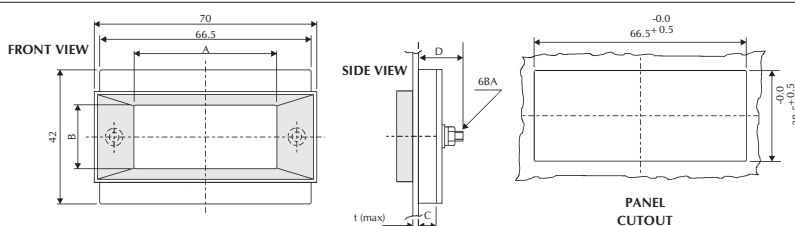
Display / Digits (max.)		3½ Digits, 1999 Counts LCD		3½ Digits, 1999 Counts LED																			
Ranges	Models	LC035		LC135																			
DC	mV V µA mA	0 - 200 mV 0 - 2, 20, 200 V 0 - 200 µA 0 - 2, 20, 200 mA																					
Auxiliary Power Supply		Standard : 9VDC ± 10%		Standard : 5VDC ± 10%																			
		Note : Power Supply must be Isolated. Supply Ground must not be connected to IN-LO Signal. Please ensure when a shunt is used, it must be connected on Ground / Common side of the load and not on the Supply side.																					
Accuracy (Specified at 27 ± 5°C)	V DC A DC	± 0.5% of Full Scale																					
Dimensions (mm)	Front	70 x 42																					
	Depth (Behind Panel)	15		21																			
	Panel Cut-Out	66.5 (+0.5, -0.0) x 28.5 (+0.5, -0.0)																					
	Drawing																						
				<table border="1"> <thead> <tr> <th></th> <th>LC035</th> <th>LC135</th> </tr> </thead> <tbody> <tr> <td>A</td> <td>45</td> <td>50</td> </tr> <tr> <td>B</td> <td>20</td> <td>20</td> </tr> <tr> <td>C</td> <td>7.5</td> <td>10.3</td> </tr> <tr> <td>D</td> <td>15</td> <td>21</td> </tr> <tr> <td>t</td> <td>2</td> <td>2</td> </tr> </tbody> </table>			LC035	LC135	A	45	50	B	20	20	C	7.5	10.3	D	15	21	t	2	2
	LC035	LC135																					
A	45	50																					
B	20	20																					
C	7.5	10.3																					
D	15	21																					
t	2	2																					

Ordering Information : Model, Input Range & Scale Display

Terminal Connection

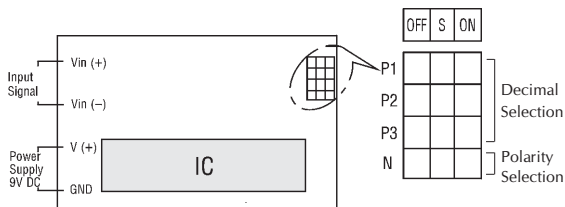

- Short S and ON to display Decimal Point, Polarity Indicator.
- Short S and OFF to prevent display of Decimal Point, Polarity Indicator.

LC035

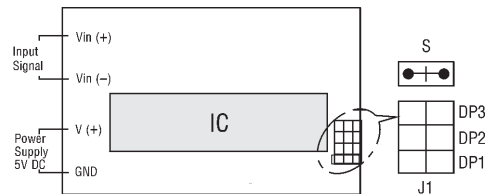

Short S to display corresponding Decimal Point.

LC135

● **What does RMS mean ?**

RMS is the Root Mean Square or effective heating of any AC Voltage or Current waveform. RMS is the equivalent DC heating value of an AC waveform.

● **What is TRMS ?**

TRMS means TRUE ROOT MEANS SQUARE VALUE.

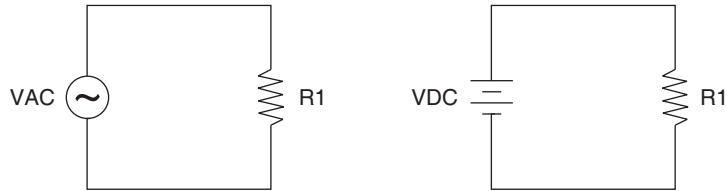

(Power consumed in R1 is same for both AC & DC source if the VAC RMS equals VDC)

● **What causes Non-Sinusoidal waveforms ?**

Waveform distortion is caused by non-linear loads which include virtually all electronics loads such as :

- Power Supplies
- Elevators
- Conveyors
- Machine Tool Drives
- High-Tech /IT-Intensive Environments
- Solid State Electronics
- Variable Frequency / Speed Drives
- Fan Controls
- Motor Controls
- High Efficiency HVAC Systems
- Low Voltage Systems
- Phase Controls etc. Dimmers
- Computers
- Inverters
- LED Lamps etc.

● **What is TRMS Meter ?**

TRMS Meter is a Meter which can accurately measure both Sinusoidal and Non Sinusoidal AC waveforms which usual instrument does not give Correct reading.

Sinusoidal Alternating Current Waves

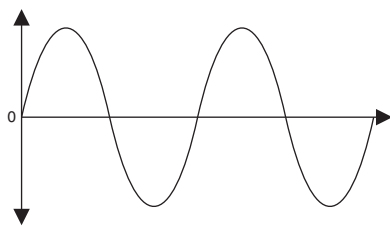

Pure, without distortion, with symmetrical transitions between peaks and valleys.

Non Sinusoidal Waves

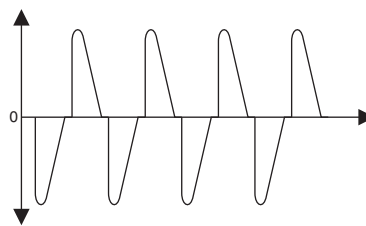

Waves with distorted, irregular patterns-spikes, pulse trains, squares, triangles, sawtooths and any other ragged or angular waves.

● **Response of TRMS Meter vs Average Reading Meter**

Meter Type	Response to Sine Wave	Response to Square Wave	Response to Single Phase Diode Rectifier	Response to 3 Phase Diode Rectifier
Average Reading	✓	10% High	40% Low	5% to 30% Low
TRMS Reading	✓	✓	✓	✓

Thus the Average - Reading Meter will give bad readings for Non Sinusoidal Wave Shape Measurements. The TRMS Meter will give accurate readings as shown above.

● **MECO Offers a Complete Range of Measuring Instruments for all Your TRMS Applications :**



Multifunction Meter

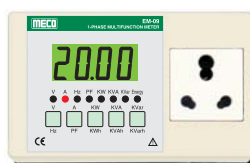

Energy Meter / Appliance Tester



Digital Panel Meter



Transducer



Multimeter



Clampmeter

BLUE STAR

Blue Star Limited
Rock 2/A, DLF Corporate Park,
DLF Phase 1, Gurgaon Road,
Gurgaon (Haryana) 122 002, India
Tel : +91 124 409 4800
Fax : +91 124 409 4800
www.bluestarindia.com

Di 16.12.2015

M/s. Mecco Instruments Pvt. Ltd.
Plot No. 1, MIDC Electronic Zone,
TTC Industrial Area, Mahape, Navi Mumbai – 400 710
Tel. No. 022 – 27673300 Fax No. 022 – 27673310

Kind Attn Mr Haren Shah

Sub Performance of MECO Make Power Line Transducers for Delhi Metro Rail Corporation (DMRC – Delhi)

Please refer our Purchase orders to MECO Instruments Pvt. Ltd. Mahape, Navi Mumbai for Supply of MECO Make Power Line Transducers for Delhi Metro Rail Corporation (DMRC – Delhi) Projects.

Performance of MECO Make Power Line Transducers (Current, Voltage, Power Factor, Active Power, Reactive Power & Frequency Transducers) supplied to us are as per specification and working satisfactory at DMRC Sites.

We look forward to have similar kind of service and support in future also.

Thanking You,



Gaurav Khator
Blue Star Ltd, Gurgaon

Registered Office: Sector 4 Building, Midway T-Block Chowk, Landmark T-Block, Mumbai 400 008, India. Tel : +91 22 6665 4800 Fax : +91 22 6665 4152
CN 1 204209 01999PC 000003

25 JAN 2007

पावर ग्रिड कारपोरेशन ऑफ इंडिया लिमिटेड
POWER GRID CORPORATION OF INDIA LIMITED
(A Government of India Enterprise) **पावरग्रिड**

केन्द्रीय कार्यालय : "सादामिनी" प्लॉट नं. 2, सेक्टर-29, गुडगाँव-122 001, हरियाणा
फोन : 2571700 - 719, फैक्स : 2571760, 2571761 वार "नेटग्रिड"
Corporate Office : "Saudamini" Plot No. 2, Sector-29, Gurgaon-122 001, Haryana
Tel. : 2571700 - 719, Fax : 2571760, 2571761 Gram : NATGRID

संदर्भ संख्या/Ref. Number
C/QA&I/SV
January 23, 2007

M/s Mecco instruments Pvt. Ltd.,
Plot No EL-1, MIDC Electronic Zone,
TTC Industrial Area, Mahape,
Navi Mumbai-400710
Fax No. 022-27673310/27673330

Kind Attn : **Shri Kamal Goliya (CEO)**

Sub : Approval of MECO Make Indicating Instruments, Transducers & Meters.

Dear Sir,

This has reference to your letter no. nil dated 17.01.2007. In this regard, we have reviewed your request and hereby convey our approval of MECO Instruments Pvt. Ltd., Mumbai (MECO make) as a vendor for supply of indicating instruments, meters (analog and digital), transducers, indicating meters with transducers under LT Panel, DG sets, AC & DC Control Panels, Miscellaneous erection items for switchyard, transformer & reactors and control & relay panel packages for POWERGRID projects. This approval will be treated in continuation to our approval accorded vide letter no. C/QA&I/SV dated 23.01.2004.

Thanking you,

Yours faithfully,

(D. CHAKRABORTY)
DY. GENERAL MANAGER (QA&I)

पंजीकृत कार्यालय : बी-9, आउट इन्स्टीट्यूशनल एरिया, काठवाड़ा नगर, नई दिल्ली-110016 दूरभाष : 26560121 फैक्स : 011-26560039 वार "नेटग्रिड"
Registered Office : B-9, Outab Institutional Area, Katwaria Sarai, New Delhi-110016 Tel. : 26560121 Fax : 011-26560039 Gram : NATGRID

GE
Intelligent Platforms

OM: U7200KA3897P1E322138
Vishwani Tech Park, No 43
1st floor, Building D
Electronics City, Haveli Road
Bangalore 560 300
Website: www.ge.com
T + 91 80 4251 5300-04
F + 91 80 4251 5305-06

Ref: Vendor/Approval/75-18
Date : 01/15/2015

To,
M/S. Mecco Instruments Pvt. Ltd.
Plot NO. EL-1, MIDC Electronic Zone,
TTC Industrial Area, Mahape
Navi Mumbai – 400 710,
Tel No. : 022 27673300
Fax No. : 022 27673330
Email : kamal@meecoinst.com

Kind Attn : **Mr. Kamal Goliya /P. Sawade**

Sub: Vendor Approval

We thank you for your support extended to us for supply of various Electrical and Electronic Testing and Measuring Instruments and Transducers.

We have been using MECO Multifunction Meters, Digital Panel Meters, Power Line Transducers, Testing and Measuring Instruments. Since more than past 5 years in our DMRC projects to our complete satisfaction.

The pre-sales and post-sales service and support offered are prompt and timely.

We hope to have similar support from your organization for future years too so that we can all mutually achieve higher targets.

We once again thank you for your support extended to fulfill our customer needs.

Yours faithfully,
For GE Intelligent Platforms Pvt Ltd,

Classical K.M.
Sourcing Expert



Registered Office: GE Intelligent Platforms, CN: U7200KA3897P1E322138, Vishwani Tech Park, 1st Floor, Building D, B-9, Electronics City,
Haveli Road, Bangalore - 560 300, India. T + 91 80 42525300-04, F + 91 80 42515305-06

Raychem RPG Limited
(Industrial Electronics Division)

P-308 TTC Industrial Area, MIDC, Rabale, Navi Mumbai 400 705
Tel. : (022) 2648 6318, 2616 6319, 2616 6304 Fax: (022) 2764 2444
E-mail : cs@raychem.com | raychem@raychem.com | Website: www.raychemrpg.com

30.03.2007

To,
Mecco Instruments Pvt. LTD.
EJ-1, MIDC, Electronics Zone,
Mahape, Navi Mumbai

Attn: Mr. Kamal Goliya

Dear Sir,

We are glad to inform you that we are very much satisfied with the performance of your panel meters, testing equipments, & especially the transducers, which we have installed at various location across India & in Export market.

We hope that the same support will be extended to us in future also, as it will strengthen our business relations.

Once again thanks to all your team!

Thanks & warm regards,
For RAYCHEM RPG LTD.

(Millesh Janye)
Procurement



Regt. Office: C-5, Mahatma Anand, 463, D: Anvee Besant Road, Mumbai 400 000, India.
Tel.: (022) 2483 7485 / 6 / 7 Fax: (022) 2493 8879

MECO®

SINCE 1962

Power Line Transducers

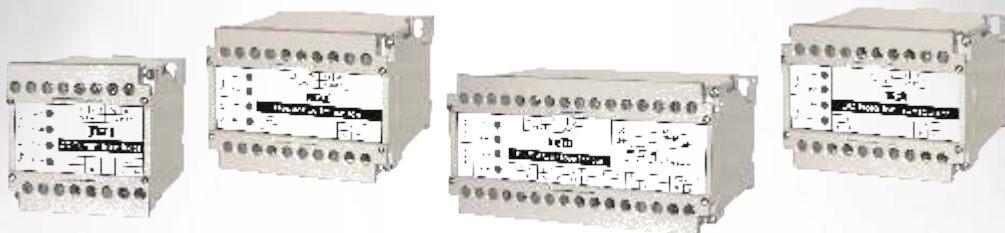

Reliable, Long-Lasting and Affordable Instruments ...since 1962 !

www.mecoinst.com

An ISO 9001-2008 Certified Company

MECO INSTRUMENTS PRIVATE LTD.

NAVI MUMBAI



Introduction

MECO Power Line Transducers were designed by MICRO DENSHI CORPORATION of Japan for AC Power Line parameters like Voltage, Current, Wattage, Var, Power Factor, Frequency, DC Isolation, and TAP Position.

These reliable and accurate Transducers are in applications in all sectors of the power and process industry since over 15 years.

These Transducers give a load independent and isolated DC output directly proportional to the input parameters.

MECO Transducers are widely used for automation and control of the power and process systems as well as for local and remote monitoring of the electrical parameters at every stage of electricity generation, transmission & distribution. They are ideal for SCADA, energy management, telemetry, data-logging as well as central monitoring systems.

MECO Transducers are generally designed to comply to the requirements of IEC 688 / EN 60688, EN 61010-1, EN 61326-1 and I.S. 12784 (Part 1). All MECO Transducers pass through a stringent manufacturing and in-house quality control process consisting of vibration, burn-in and calibration tests to ensure complete reliability and accuracy during the continuous operation.

MECO Transducers can also be supplied mounted in Panel with complete wiring and accessories upto termination point for applications in various industries like Power Utilities, SEB's, Cement, Steel, Aluminum, Chemicals, Fertilizers, Sugar, Petrochemicals etc.

Features

- Terminal Protection Cover
- Reliable & Rugged Static Circuits
- Low Ripple in Output Signal
- Flame Retardant Polycarbonate Case
- Choice of Multiple Asymmetrical Outputs
- Wide Choice of Suppressed Ranges
- Open and Short Circuit Protection for Outputs
- Dual Output (Non Isolated)
- Self-Powered, AC, DC, SMPS Auxillary Supply
- Din Rail Mounting
- Bi-Directional Outputs
- Fast Response Time
- Bi-Directional Inputs for Import / Export



DIN Rail cum Back Panel Mounting

■ Fixing Holes for Back Panel Mounting ■

■ Provision for DIN Rail Mounting

Reliable, Rugged & Static Electronic Circuit using High Stability Components

Terminal Protection Strip

■ Terminal Protection Strip

Flame Retardant Polycarbonate (UL94V-0) Self Extinguishing, Non Drip Casing

Types

- AC Current (Average / TRMS)
- AC Voltage (Average / TRMS)
- Frequency
- Active Power (TRMS) (1P & 3P - Balanced or Unbalanced System)
- Reactive Power (TRMS) (1P & 3P - Balanced or Unbalanced System)
- Power Factor (Zero Crossing / TRMS) (1P & 3P - Balanced or Unbalanced System)
- DC Isolation for Voltage & Current
- Tap Position / OLTC

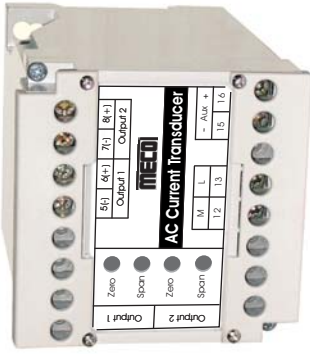
Sr.	 <p>DIN Series</p>	Auxiliary Power Supply				Type of Input		Type of Output				Isolation	Other		
		110 / 230V AC	24 / 48 / 110 / 220V DC	SMPS - LV (19-90V AC / DC)	SMPS - HV (85-265V AC / DC)	Self Powered	Bi Directional	Expanded / Suppressed	Single / Dual (Symmetrical / Asymmetrical)	Dual (Non-Isolated)	Bi-Directional	Expanded / Suppressed	2.5KV Between Input / Output / Aux. / Case	Average	TRMS
1	AC Current	✓	✓	✓	✓	✓	NA	✓	✓	✓	✓	✓	✓	✓	✓
2	AC Voltage	✓	✓	✓	✓	✓	NA	✓	✓	NA	✓	✓	✓	✓	✓
3	W / KW / MW (1P 1E 2W) - TRMS	✓	✓	✓	✓	✓	✓	✓	✓	✓	✓	✓	NA	✓	✓
4	W / KW / MW (3P 1E - Balanced Load) - TRMS	✓	✓	✓	✓	✓	✓	✓	✓	✓	✓	✓	NA	✓	✓
5	W / KW / MW (3P 2E 3W - Balanced & Unbalanced Load) - TRMS	✓	✓	✓	✓	✓	✓	✓	✓	✓	✓	✓	NA	✓	✓
6	W / KW / MW (3P 3E 4W - Balanced & Unbalanced Load) - TRMS	✓	✓	✓	✓	✓	✓	✓	✓	✓	✓	✓	NA	✓	✓
7	Var / KVar / MVar (1P 1E 2W) - TRMS	✓	✓	✓	✓	✓	✓	✓	✓	✓	✓	✓	NA	✓	✓
8	Var / KVar / MVar (3P 1E - Balanced Load) - TRMS	✓	✓	✓	✓	✓	✓	✓	✓	✓	✓	✓	NA	✓	✓
9	Var / KVar / MVar (3P 2E 3W - Bal. & Unbal. Load) - TRMS	✓	✓	✓	✓	✓	✓	✓	✓	✓	✓	✓	NA	✓	✓
10	Var / KVar / MVar (3P 3E 4W - Bal. & Unbal. Load) - TRMS	✓	✓	✓	✓	✓	✓	✓	✓	✓	✓	✓	NA	✓	✓
11	Frequency Transducer	✓	✓	Under development	Under development	✓	NA	✓	✓	NA	✓	✓	✓	NA	✓
12	PF (1P 1E 2W) - Zero Crossing	✓	✓	Under development	Under development	✓	✓	✓	✓	✓	✓	✓	✓	NA	✓
13	PF (3P 1E 2W - Balanced Load) - Zero Crossing	✓	✓	Under development	Under development	✓	✓	✓	✓	✓	✓	✓	✓	NA	✓
14	PF (3P 2E 3W - Balanced & Unbalanced Load) - TRMS	✓	✓	Under development	Under development	✓	✓	✓	✓	✓	✓	✓	NA	✓	✓
15	PF (3P 3E 4W - Balanced & Unbalanced Load) - TRMS	✓	✓	Under development	Under development	✓	✓	✓	✓	✓	✓	✓	NA	✓	✓
16	DC Isolation / DC-DC Converter for Current and Voltage	✓	✓	Under development	Under development	NA	✓	✓	✓	✓	✓	✓	✓	NA	✓
17	TAP Position Transducer	✓	✓	Under development	Under development	NA	NA	✓	✓	NA	✓	✓	✓	NA	✓

Note : ✓ Indicates choice of Standard / Optional features possible for DIN Series. Please specify your requirement of all Standard / Optional specifications clearly at the time of ordering. NA denotes not applicable.

Specifications

Accuracy	± 0.5% of Span (standard) Others on request (optional)	Warm Up Time	20 min. (approx.)
Accuracy Range	0 to 120%	Dielectric Strength	2.5kV at 50 Hz for 1 min.(Standard) 4kV (Optional), across Casing - Input/Output/Auxiliary Input - Output Input - Auxiliary Output - Auxiliary
Zero Adjustment	± 2% of Span (min.)	Impulse Test	5kV, 1.2 / 50µS
Span Adjustment	± 10% of Span (min.)	Casing	DIN Series Flame Retardant, Polycarbonate (UL 94V-0) Self Extinguishing, Non Drip, DIN Rail cum Wall Mounting Casing
Response Time	< 250 ms for 0 to 90% of Output < 1 s for 0 to 90% of Output for PF	Applicable Standards	IEC 688 / EN 60688 Electrical Measuring Transducers for converting AC Electrical Quantities to Analog or Digital Signals EN 61010-1 Safety requirements for Electrical Equipment for Measurement Control & Laboratory use EN 61326-1 Electrical Equipment for Measurement Control & Laboratory use - EMC requirements IS12784 (Part-1)1989 Electrical Measuring Transducers for converting AC Electrical Quantities into DC Electrical Quantities : General Purpose Transducer
Output Ripple	< 0.5% of Full Scale		
Compliance Voltage	12VDC (max.)		
Overload - Continuous	Voltage : 1.2 x Un Current : 2 x In		
Overload - Short Duration (1 sec.)	Voltage : 2 x Un Current : 20 x In		
Max. Open Circuit Voltage	< 30VDC		
Stability	± 0.25% Per Annum, Non Cumulative		
Environmental Conditions	As per IEC 688 User Group II		
Operating Temperature	0 to 55 °C, RH < 95% (non condensing)		
Storage Temperature	-20 to 70 °C, RH < 95% (non condensing)		
Calibrated At	27 °C ± 5 °C		
Temperature Coefficient	0.02% / °C		
Isolation	Complete (Input/Output/Auxiliary/Case)		
Insulation Resistance	> 100MΩ at 500VDC		
Self Powered (optional)	Max.Variation of ± 20% in input voltage		

Ordering Information

Model, Input Range, Input Voltage, Input Current, PTR, CTR, Frequency, Auxiliary Supply, Output 1, Output 2 & Optionals

Dimensions (in mm)

DIN Series

Case Size	A	B	C	D	E	F	G	H
I	75	60	112	70	35	73	50	60
II	100	85	112	70	35	73	50	60
III	150	135	112	70	35	73	50	60

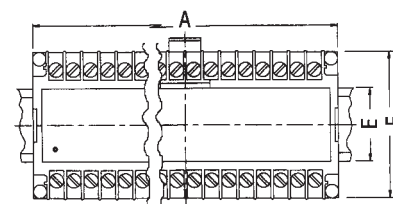
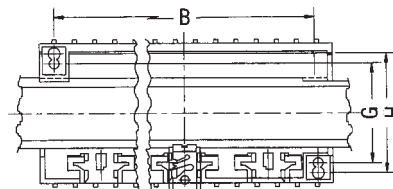
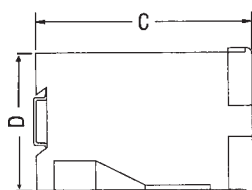

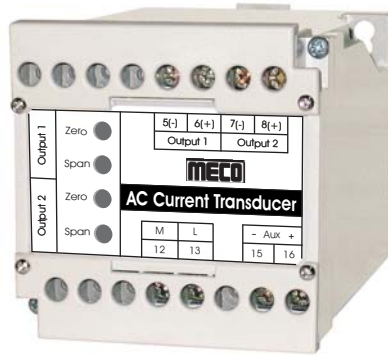

CMT, CMT - TRMS

MECO AC Current Transducers measure AC Current and converts it to an industry standard output signal which is directly proportional to the measured input. These Transducers provide an output which is load independent and isolated from the input. The output can be connected to Controllers, Data-Loggers, PLC's, Analog / Digital Indicators, Recorders for display, analysis or control. They are ideal for SCADA, Energy Management, Telemetry for Remote, Local as well as Central Monitoring Systems.

Type	DIN Series
Current - Average	CMT
Current - TRMS	CMT - TRMS

AC Input		DC Output ^{*1,*2}				Auxiliary Power Supply		
		Current		Voltage		Tolerance		Burden
Input Ranges	0 - 5A (Direct) 0 - 1A (Direct) CTR / 5A CTR / 1A	Output	Load	Output	Load	SMPS - HV	85 - 265V AC / DC	< 2 VA
Measuring Range	0 - 1.2 I _n	0-1 mA	0-10 KΩ	0-1 V	> 1 kΩ	SMPS - LV	19 - 90V AC / DC	
Overload (continuous)	2 x I _n	0-5 mA	0-2 KΩ	0-5 V	> 5 kΩ	Self ^{*1} Powered	*1 For Input 1A & 5A AC, Output 0-10 or 0-20mA DC Available Only	Refer Input Burden
Burden	< 0.5 VA *2 < 6 VA for Self Powered	0-10 mA	0-1 KΩ	1-5 V	> 10 kΩ			
		2-10 mA	0-500 Ω	0-10 V				
		0-20 mA		2-10 V				
		4-20 mA						

Optional

- Expanded or Suppressed Input Ranges
Example : 0 - 0.8 - 1.2 I_n
- Other input ranges available subject to technical feasibility

Optional

- Dual Non-Isolated Outputs
- Expanded / Suppressed Output
Example : 4 - 6 - 20 mA for 0 - 0.8 - 1.2 I_n
- Dual Symmetrical / Asymmetrical Outputs
- Other output ranges available subject to technical feasibility

Optional

- Other Auxiliary Power Supplies available subject to technical feasibility

Dimension

- DIN Series :**
- Case Size II for Self Powered
 - Case Size I for others

- Note :**
- For Case Size refer General Specifications

Connection Diagram

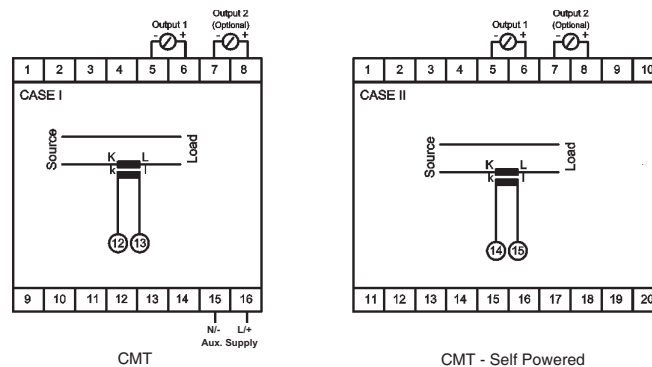

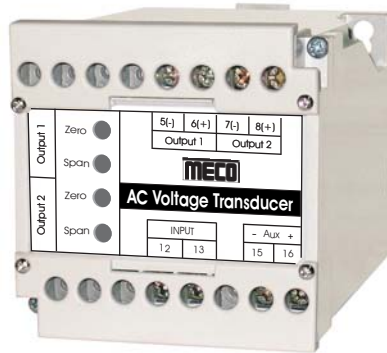

VMT, VMT - TRMS

MECO AC Voltage Transducer measures AC Voltage and converts it to an industry standard output signal which is directly proportional to the measured input. These Transducers provide an output which is load independent and isolated from the input. The output can be connected to Controllers, Data-Loggers, PLC's, Analog / Digital Indicators, Recorders for display, analysis or control. They are ideal for SCADA, Energy Management, Telemetry for Remote, Local as well as Central Monitoring Systems.

Type	DIN Series
Voltage - Average	VMT
Voltage - TRMS	VMT - TRMS

AC Input		DC Output				Auxiliary Power Supply		
Input Ranges	0 - 63.5 V 0 - 110 V 0 - 230 V 0 - 300 V 0 - 440 V 0 - 500 V	Current		Voltage		Tolerance		Burden
Measuring Range	0 - 1.2Un	Output	Load	Output	Load	SMPS - HV	85 - 265V AC / DC	< 2 VA
Overload (continuous)	1.2 x Un	0-1 mA	0-10 KΩ	0-1 V	> 1 kΩ	SMPS - LV	19 - 90V AC / DC	
Burden	< Un x 5.5mA < 6 VA for Self Powered	0-5 mA	0-2 KΩ	0-5 V	> 5 kΩ	Self Powered	Max. Variation of ± 20% allowed in Input Voltage	Refer Input Burden
		0-10 mA	0-1 KΩ	1-5 V				
		2-10 mA		0-10 V				
		0-20 mA	0-500 Ω	2-10 V	> 10 kΩ			
		4-20 mA						

Optional

- Expanded or Suppressed Input Ranges also available. Example : 0 - 0.8 - 1.2 Un
- Above Input Ranges with suitable PTR also available.
- Other input ranges available subject to technical feasibility

Optional

- Dual Non-Isolated Outputs
- Expanded or Suppressed Output Example : 4 - 6 - 20 mA for 0 - 0.8 - 1.2 Un
- Dual Symmetrical & Asymmetrical Outputs
- Other output ranges available subject to technical feasibility

Optional

- Other Auxiliary Power Supplies available subject to technical feasibility

Dimension

DIN Series : ● Case Size I

Note : ● For Case Size refer General Specifications

Connection Diagram

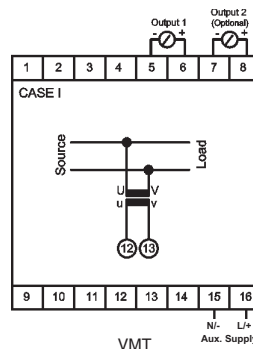



FT

MECO Frequency Transducer measures Power Frequency over a specified Frequency Range and converts it to an industry standard output signal which is directly proportional to the measured input. These Transducers provide an output which is load independent and isolated from the input. The output can be connected to Controllers, Data-Loggers, PLC's, Analog / Digital Indicators, Recorders for display, analysis or control. They are ideal for SCADA, Energy Management, Telemetry for Remote, Local as well as Central Monitoring Systems.

Model : FT (DIN Series)

AC Input		DC Output				Auxiliary Power Supply		
Input Ranges	45 - 55 Hz 45 - 65 Hz 55 - 65 Hz	Current		Voltage		Tolerance (± 20 %)		Burden
Input Voltage	63.5/110/230/440 V (any one only)	Output	Load	Output	Load	AC Linear Power Supply	110 V 230 V	< 4 VA
Measuring Range	0.8 - 1.2 Un	0-1 mA	0-10 KΩ	0-1 V	> 1 kΩ			
Overload (continuous)	1.2 x Un	0-5 mA	0-2 KΩ	0-5 V	> 5 kΩ			
Burden	< Un x 5.5mA < 6 VA for Self Powered	0-10 mA	0-1 KΩ	1-5 V	> 10 kΩ			
		2-10 mA		0-10 V				
		0-20 mA	0-500 Ω	2-10 V		DC	24 V	
		4-20 mA					48 V	
						110 V		
						220 V		
						Self Powered	Max. Variation of ± 20% allowed in Input Voltage	Refer Input Burden

Optional

- Above Input Ranges with suitable PTR also available
- Other input ranges available subject to technical feasibility

Optional

- Dual Non-Isolated Outputs
- Dual Symmetrical & Asymmetrical Outputs
- Other output ranges available subject to technical feasibility

Optional

- Other Auxiliary Power Supplies available subject to technical feasibility

Dimension

DIN Series : ● Case Size II

Note : ● For Case Size refer General Specifications

Connection Diagram

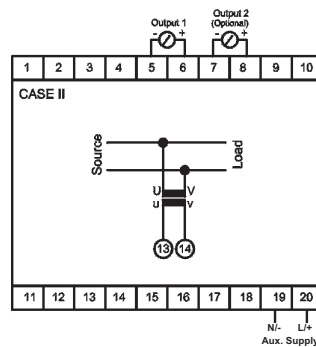

FT



DTI



DTI - RRL

MECO DC Isolation Transducer takes various DC Voltage or DC Current signal inputs and provides a Stable, Ripple-Free and Optically Isolated DC load independent output in the form of current or voltage. The output can be connected to Controllers, Data-Loggers, PLC's, Analog / Digital Indicators, Recorders for display, analysis or control. They are ideal for SCADA, Energy Management, Telemetry for Remote, Local as well as Central Monitoring Systems. Model DTI - RRL has LED indication at Power ON condition.

Model : DTI (DIN Series)				Model : DTI - RRL (DIN Series)						
DC Input				DC Output				Auxiliary Power Supply		
Input Ranges	0-100 mV 0-1 V 0-5 V 1-5 V 0-10 V 2-10 V 0-1000 V	4-20 mA 2-10 mA 1-5 mA 0-1 mA 0-10 mA 0-16 mA 0-20 mA		Current		Voltage		Tolerance		Burden
Measuring Range	0-1.2 In, 0-1.2 Un		Output	Load	Output	Load	SMPS - HV	85 - 265V AC / DC	< 2.5 VA	
Overload (continuous)	1.2 x Un, 2 x In		0-1 mA	0-10 KΩ	0-1 V	> 1 kΩ	SMPS - LV	19 - 90V AC / DC		
Burden	10 kOhm/V for Voltage 100 mV for Current		0-5 mA	0-2 KΩ	0-5 V	> 5 kΩ			AC Linear Power Supply	110 V ± 20 % 230 V ± 20 %
Bi-directional Inputs	-50/0/50 mV DC to -300/0/300 V DC		0-10 mA	0-1 KΩ	1-5 V	> 10 kΩ				
			2-10 mA	0-500 Ω	0-10 V					
			0-20 mA		2-10 V					
			4-20 mA							
			4-12-20 mA	0-500 Ω	0-5-10 V	> 10 kΩ				

Optional

- Bi-directional Inputs available
- Other input ranges available subject to technical feasibility

Optional

- Dual Non-Isolated Outputs
- Dual Symmetrical & Asymmetrical Outputs
- Bi-directional Outputs
- Other output ranges available subject to technical feasibility

Optional

- Other Auxiliary Power Supplies available subject to technical feasibility

Dimension

DIN Series : ● Case Size II

Note : ● For Case Size refer General Specifications

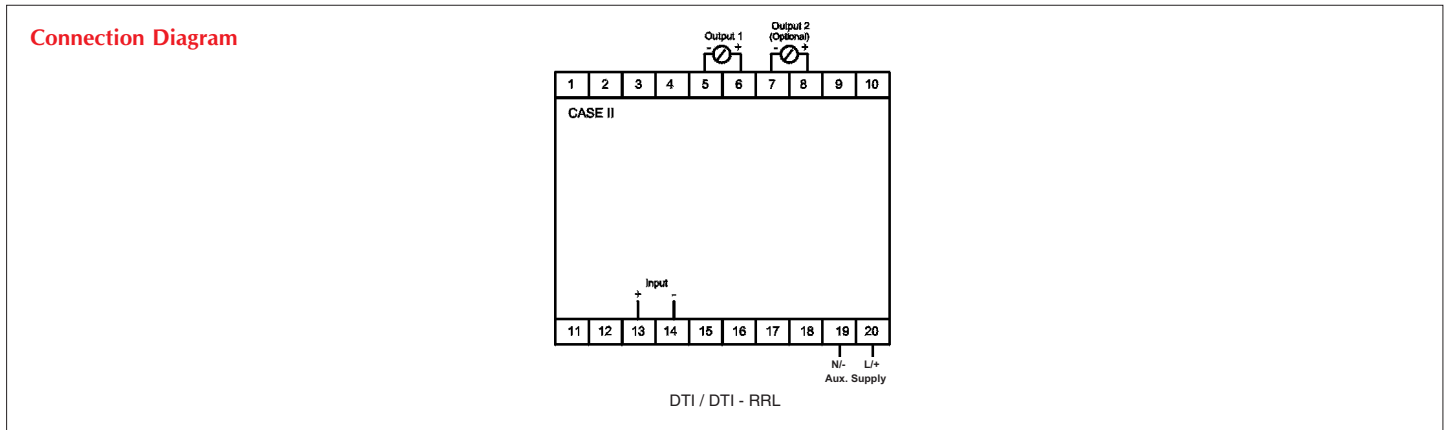

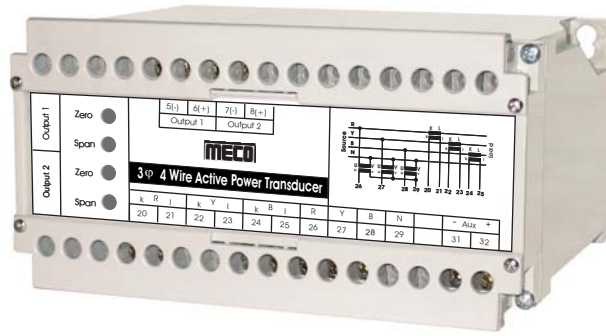

WT, RPT

MECO AC Active Power (Watt) & Reactive Power (Var) Transducers measure Power in 1 Phase, 3 Phase 3 Wire and 3 Phase 4 Wire in balanced or unbalanced electrical systems and converts it to an industry standard output signal which is directly proportional to the measured input. These Transducers provide an output which is load independent and isolated from the input. These Transducers can measure both Import and Export of Power. The output can be connected to Controllers, Data-Loggers, PLC's, Analog / Digital Indicators, Recorders for display, analysis or control. They are ideal for SCADA, Energy Management, Telemetry for Remote, Local as well as Central Monitoring Systems.

Type	Watt	Var
1Phase 1Element 2Wire - TRMS	WT11	RPT11
3Phase 1Element 2Wire (Balanced) - TRMS	WT31	RPT31
3Phase 2Element 3Wire (Balanced & Unbalanced) - TRMS	WT33	RPT33
3Phase 3Element 4Wire (Balanced & Unbalanced) - TRMS	WT34	RPT34

AC Input	
Input Voltage	0-63.5/110/230/440 V (any one only)
Input Current	0-1/5 A (any one only)
Input Frequency	50/60/400 Hz (any one)
Input PF Range	0 (Lag) - 1 - 0 (Lead)
Measuring Range	0-1.2 x Un x In
Overload (continuous)	2 x In and 1.2 x Un
Burden (Voltage)	< Un x 5.5mA/Phase < 6 VA for Self Powered
Burden (Current)	< 0.5VA / Phase

DC Output			
Current		Voltage	
Output	Load	Output	Load
0-1 mA	0-10 KΩ	0-1 V	> 1 kΩ
0-5 mA	0-2 KΩ	0-5 V	> 5 kΩ
0-10 mA	0-1 KΩ	1-5 V	> 10 kΩ
2-10 mA		0-10 V	
0-20 mA	0-500 Ω	2-10 V	
4-20 mA			

Auxiliary Power Supply		
	Tolerance	Burden
AC Linear Power Supply	110 V ± 20%	< 4 VA
	230 V ± 20%	
DC	24 V ± 20%	
	48 V ± 20%	
	110 V ± 20%	
	220 V ± 20%	
SMPS-HV	85-265 V AC/DC	< 2 VA
SMPS-LV	19-90 V AC/DC	
Self Powered	Max. Variation of ± 20% allowed in Input Voltage	Refer Input Burden

Optional

- Above Input Ranges with suitable CTR/PTR also available
- Bi-directional inputs for Import / Export of Power

Optional

- Dual Non-Isolated Outputs
- Dual Symmetrical & Asymmetrical Outputs
- Bi-directional Outputs

Optional

- Other Auxiliary Power Supplies available subject to technical feasibility

Dimension

- DIN Series :**
- Case Size II for 1 Phase
 - Case Size III for 3 Phase

- Note :**
- For Case Size refer General Specifications

Connection Diagram

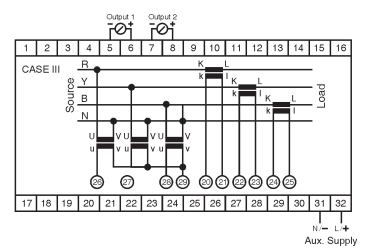
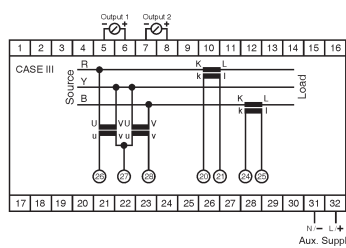
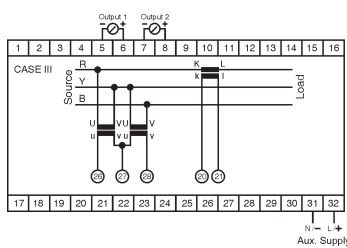
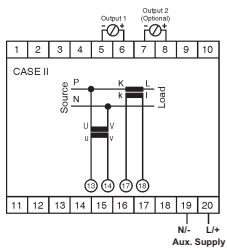

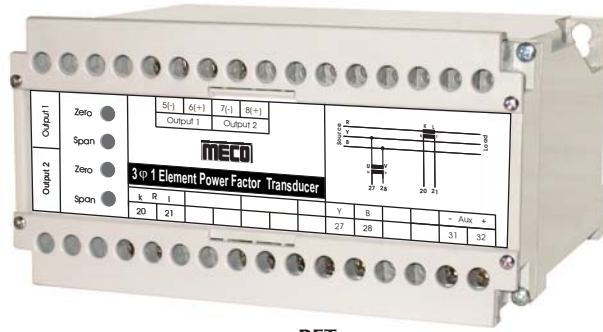

PFT

MECO AC Power Factor Transducers measure the Power Factor in 1 Phase and 3 Phase electrical systems. The resulting output signal is directly proportional to the system power factor. These Transducers provide an output which is load independent and isolated from the input. The output can be connected to Controllers, Data-Loggers, PLC's, Analog / Digital Indicators, Recorders for display, analysis or control. They are ideal for SCADA, Energy Management, Telemetry for Remote, Local as well as Central Monitoring Systems.

Type	DIN Series
1Phase 1Element 2Wire - Zero Crossing	PFT11
3Phase 1Element 2Wire (Balanced) - Zero Crossing	PFT31
3Phase 2Element 3Wire (Balanced & Unbalanced) - TRMS	PFT33-TRMS
3Phase 3Element 4Wire (Balanced & Unbalanced) - TRMS	PFT34-TRMS

AC Input	
Input Voltage	63.5/110/230/440 V (any one only)
Input Current	1/5 A (any one only)
Input Frequency	50/60 Hz (any one)
Input PF Range	0.5 (Lag) -1.0 - 0.5 (Lead) 0.8 (Lag) -1.0 - 0.2 (Lead)
Measuring Range	0.8Un ~ 1.2Un, 0.2In ~ 1.2In
Overload (continuous)	2 x In and 1.2 x Un
Burden (Voltage)	< Un x 5.5mA/Phase < 6 VA for Self Powered
Burden (Current)	< 0.5VA / Phase

DC Output			
Current		Voltage	
Output	Load	Output	Load
0-1 mA	0-10 KΩ	0-1 V	> 1 kΩ
0-5 mA	0-2 KΩ	0-5 V	> 5 kΩ
0-10 mA	0-1 KΩ	1-5 V	> 10 kΩ
2-10 mA		0-10 V	
0-20 mA	0-500 Ω	2-10 V	
4-20 mA			

Auxiliary Power Supply		
	Tolerance (± 20 %)	Burden
AC Linear Power Supply	110 V	< 4 VA
	230 V	
DC	24 V	
	48 V	
	110 V	
	220 V	
Self Powered	Max. Variation of ± 20% allowed in Input Voltage	Refer Input Burden

Optional

- Above Input Ranges with suitable CTR/PTR also available
- Bi-directional inputs for Import / Export of Power

Optional

- Dual Non-Isolated Outputs
- Dual Symmetrical & Asymmetrical Outputs
- Bi-directional Outputs

Optional

- Other Auxiliary Power Supplies available subject to technical feasibility

Dimension

DIN Series : ● Case Size III

Note : ● For Case Size refer General Specifications

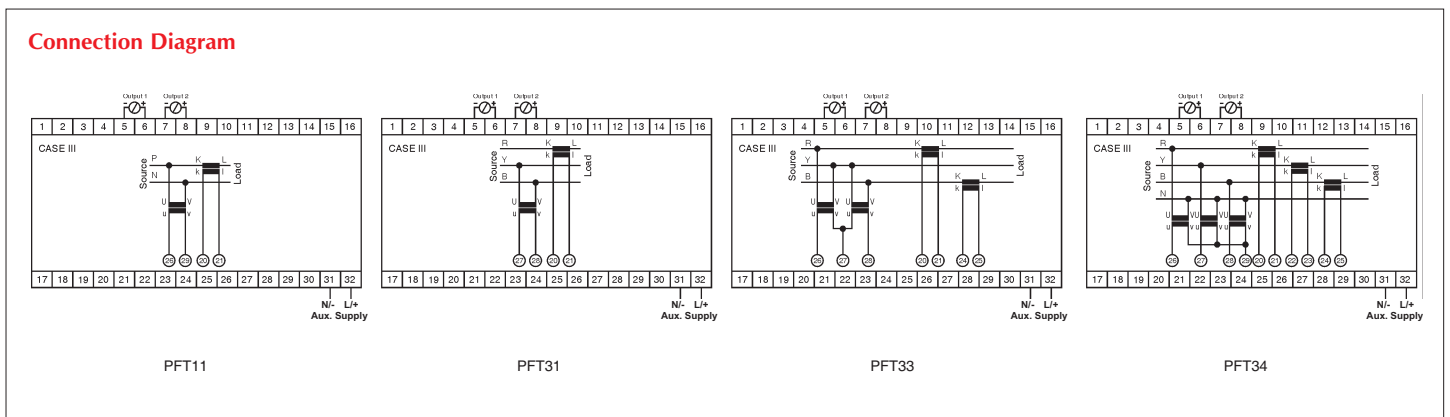



TPT

MECO Tap position Transducer takes various Resistance inputs and provides a Stable, Ripple-Free and Optically Isolated DC load independent output in the form of current or voltage. The output can be connected to Controllers, Data-Loggers, PLC's, Analog / Digital Indicators, Recorders for display, analysis or control. They are ideal for SCADA, Energy Management, Telemetry for Remote, Local as well as Central Monitoring Systems.

Model : TPT (DIN Series)

Resistance Input	DC Output				Auxiliary Power Supply		
	Current		Voltage		Tolerance	Burden	
Resistance input from potentiometric transformer tap positions upto 99 transformer taps. 100 KOhms max.	Output	Load	Output	Load	SMPS - HV	85 - 265V AC / DC	< 2.5 VA
	0-1 mA	0-10 KΩ	0-1 V	> 1 kΩ			
	0-5 mA	0-2 KΩ	0-5 V	> 5 kΩ			
	0-10 mA	0-1 KΩ	1-5 V	> 10 kΩ	SMPS - LV	19 - 90V AC / DC	
	2-10 mA		0-10 V				
	0-20 mA	0-500 Ω	2-10 V				
	4-20 mA						
				AC Linear Power Supply	110 V ± 20 %	< 4 VA	
					230 V ± 20 %		

Optional

- Other input ranges available subject to technical feasibility

Optional

- Dual Non-Isolated Outputs
- Dual Symmetrical & Asymmetrical Outputs
- Bi-directional Outputs
- Other output ranges available subject to technical feasibility

Optional

- Other Auxiliary Power Supplies available subject to technical feasibility

Dimension

DIN Series : ● Case Size II

Note : ● For Case Size refer General Specifications

Connection Diagram

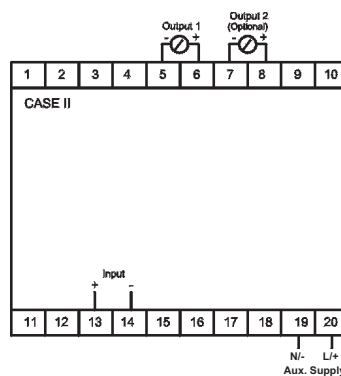

25 JAN 2007

पावर ग्रिड कारपोरेशन ऑफ इंडिया लिमिटेड
(भारत सरकार का उद्यम)
POWER GRID CORPORATION OF INDIA LIMITED
(A Government of India Enterprise)



केन्द्रीय कार्यालय : "सौदामिनी" प्लॉट सं. 2, सेक्टर-29, गुडगाँव-122 001, हरियाणा
फोन : 2571700 - 719, फैक्स : 2571760, 2571761 तार 'नेटग्रिड'
Corporate Office : "Saudamini" Plot No. 2, Sector-29, Gurgaon-122 001, Haryana
Tel. : 2571700 - 719, Fax : 2571760, 2571761 Gram : 'NATGRID'

संदर्भ संख्या/Ref. Number

C/QA&I/SV

January 23, 2007

M/s Mecco instruments Pvt. Ltd.,
Plot No.EL-1, MIDC Electronic Zone
TTC Industrial Area, Mahape,
Navi Mumbai-400710

Fax No. 022-27673310/27673330

Kind Attn. : **Shri Kamal Goliya (CEO)**

Sub : **Approval of MECO Make Indicating Instruments, Transducers & Meters.**

Dear Sir,

This has reference to your letter no. nil dated 17.01.2007. In this regard, we have reviewed your request and hereby convey our approval of MECO Instruments Pvt. Ltd., Mumbai (MECO make) as a vendor for supply of indicating instruments, meters (analog an digital), transducers, indicating meters with transducers under LT Panel, DG sets, AC & DC Control Panels, Miscellaneous erection items for switchyard, transformer & reactors and control & relay panel packages for POWERGRID projects. This approval will be treated in continuation to our approval accorded vide letter no. C/QA&I/SV dated 23.01.2004.

Thanking you,

Yours faithfully,

(D. CHAKRABORTY)
DY. GENERAL MANAGER (QA&I)



Analog Panel and Switchboard Meters

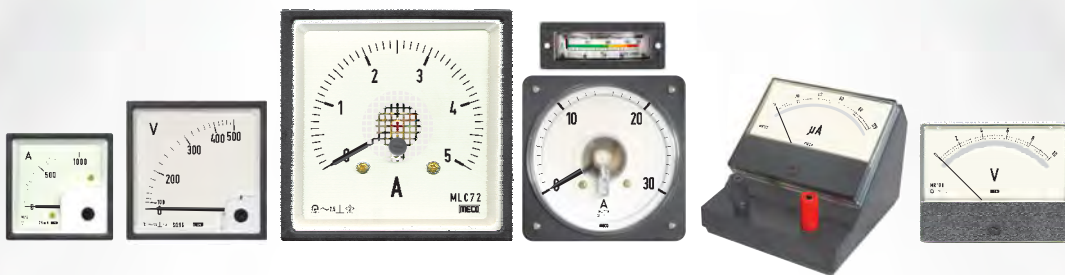

Reliable, Long-Lasting and Affordable Instruments ...since 1962 !

www.mecoinst.com
An ISO 9001-2008 Certified Company

MECO INSTRUMENTS PRIVATE LTD.
NAVI MUMBAI

General Specifications

Standards

All instruments are designed in accordance with the following international and national regulations : IS-1248; IEC-51; IEC-1010; BS89; EN60051 respectively various instruments. The overall dimensions comply with DIN43700-43718.

Technical Specifications

Materials

Case : Complies to DIN 43700
 Colour : White
 Front Frame : Complies with DIN 43718
 Colour : Black
 Front Glass : Flat glass

Protection

Case : IP52; IP54 on request
 Terminals : IP00
 IP20 (with terminal cover)

Overload Capabilities

Withstand continuous overloads of 1.2 times for Ammeter and Voltmeter the nominal value and short duration overloads of upto 10 times for Ammeter and upto 2 times for Voltmeter the nominal values for 5 seconds.

Climatic Conditions

Reference temperature for these instruments is $27^{\circ}\text{C} \pm 2^{\circ}\text{C}$. The standard instruments can operate at a maximum relative humidity of 90%.

Operating Temperature

-10°C to $+55^{\circ}\text{C}$, RH < 90%

Storage Temperature

-20°C to $+70^{\circ}\text{C}$, RH < 90%

Accuracy Class

All instruments are calibrated according to Accuracy Class specified below as per applicable international standards :

- Moving Iron Meters : 1.5
- Moving Coil Meters : 1.0, 1.5, 2.5
- Electronic Analog Watt / Var Meters : 1.5/1.0
- Power Factor Meters : $\pm 2^{\circ}$ Phase Angle
- Frequency Meters : 1.0

Influence of External Magnetic Fields

Moving Iron Meters are provided with an internal shield cup in order to prevent the influence of stray and low intensity magnetic fields.

Moving Coil and all other instruments have a center core self-shielding construction which protects against stray and external low intensity magnetic fields.

Mounting Position

The nominal operating position of the panel meters is vertical. The required mounting position is shown on the scale of the instrument. Instruments with horizontal and angular mounting positions can be supplied on request.

High Voltage Test

All instruments are designed to withstand 2.5kV RMS, 50Hz, for 1min.

Shock and Vibration Resistance

All meter movements are mounted on spring loaded shock absorbing type of jewel bearings which make the instrument capable of offering good resistance to shocks and vibration. This mechanism is much superior to traditional Taut-Band construction which is highly fragile. The Pivot Jewel mechanism is ideal for aviation, traction and marine applications.

Pointer

The pointers are in accordance with DIN 43802.

Zero Adjustment

A screw for zero adjustment is located on the front glass.

Scales

Instrument scales are in accordance with DIN43802 regulations. Special scales are available on request.

Markings and Symbols on Instruments / Meters

According to IEC51 requirements, all measuring instruments and their accessories bear on the dial, or on the external surface of the case, the markings indicating :

- Manufacturers name or trade mark
- Symbol of the measured parameter
- Accuracy / Accuracy Class
- Type of power supply and the number of measuring elements
- Test Voltage
- Operating method of the instrument
- Rated value
- Symbol for mounting position
- Symbol of the accessory or the transformer ratio for which the instrument has been calibrated.

Moving Iron Meters

These instruments consist of a moving piece of ferro magnetic material, which is under influence of a current carrying fixed coil. Considering the above mentioned operating process, these instruments are ideally suited for measuring TRMS current and voltage in alternating current circuits. Accuracy for these meters is applicable only within the nominal working range and not in the overscale range. When using external current transformer, please ensure that the secondary current value of the CT must be the rated current of the Ammeter i.e., In.

Moving Coil Meters

The operation of these instruments depends on the reaction of the current circulating in a moving coil and the field of a fixed

permanent magnet. They can be used on alternating current with a suitable rectifier inserted in the circuit.

Moving Coil instruments above 50A, the ammeters are to be used with external Shunts having 60mV or 75mV drop. The Shunts are usually calibrated for a lead resistance of usually less than 0.07 Ohm. When lead resistance is greater than 0.1 Ohm, it is advisable to use shunts of 100, 150 or 300mV drop.

Electronic Analog Watt, Var, PF & Hz Meters

These instruments are available for measuring Active and Reactive Power in single phase and three phase balanced or unbalanced load conditions. In addition to these we manufacture Power Factor Meters for single phase and three phase balanced load systems and line Frequency meters for different voltage ratings and different frequency bands.

Electronic Power meters use multiplier circuits which multiply instantaneous voltage and current.

The average of the product is in the form of analog DC current directly proportional to the AC power. This power is measured with DC moving coil meter. Scale is adjusted to indicate power. Sometimes these meters are used along with CTs and PTs. Bi-directional Watt/Var Meters to indicate export / import can be supplied on request.

In Frequency meter a DC current proportional to the input frequency is obtained by using an electronic circuit. This output is calibrated in terms of frequency.

The circuit for Powerfactor meter gives current output proportional to phase angle. This output is bidirectional to discriminate between leading and lagging Powerfactor. Scale is marked in terms of $\text{Cos}\phi$, ϕ being the phase angle between voltage and current vector.

Since these Watt meters and Var meters are self powered, it is essential that the input voltage is within $\pm 15\%$ of the nominal value. At lower voltage, the instrument will function erratically.

To get proper accuracy from Powerfactor meter, please ensure input voltage is within $\pm 15\%$ of the rated value & current is between 20% to 120% of the rated value.

Note

Power meters and Powerfactor meters are normally supplied for 47 to 53 Hz operation. On request meters to suit 60Hz or 400 Hz can be supplied.

Active power, Reactive power & Low Powerfactor Wattmeter are calibrated at $\text{Cos}\phi = 1$, $\text{Sin}\phi = 1$ and $\text{Cos}\phi = 0.2$ Lag respectively.

Burden

Electronic meters impose lower burden on supply than the conventional meters. Typical values are given below.

Watt & Var Meters		1-Phase, 230/250V	< 1.0
Voltage Rating	Total Burden(VA)	3-Phase, 110V	< 0.4
1-Phase, 63.5V	< 0.5	3-Phase, 400/440V	< 1.5
1-Phase, 230/250V	< 2.0	Current Rating	Total Burden (VA)
3-Phase, 110V	< 3x0.5	1.0 A	< 0.5
3-Phase, 400/440V	< 3x2.0	5.0 A	< 0.5
Current Rating	Total Burden (VA)	Frequency Meters	
1.0A	< 1VA/Phase	Voltage Rating	Total Burden (VA)
5.0A	< 1VA/Phase	63.5V	< 0.7
Powerfactor Meters		110V	< 1.2
Voltage Rating	Total Burden (VA)	230/250V	< 2.5
1-Phase, 63.5V	< 0.25	400/440V	< 4.5

Scale

Watt & Var Meters

Upper limits of measuring range is one of the decimal or subdecimal values from the following,

1, 1.2, 1.5, 2, 2.5, 3, 4, 5, 6, 7.5 & 8.

In the interest of standardisation it is recommended that the maximum value of the measuring range is chosen accordingly. Following examples will illustrate the method of working out these values.

i) Single Phase

$$V = 250V, I = 5A, \text{Cos}\phi = 1$$

$$\text{Power} = V.I.\text{Cos}\phi = 250 \times 5 \times 1 = 1250W$$

Maximum upper limit in this case should be 1200 or 1500W.

ii) Three Phase

$$V = 110V, \text{PTR} = 33k V/110V$$

$$I = 5A, \text{CTR} = 500/5A, \text{Cos}\phi = 1$$

$$\text{Power} = \sqrt{3}.V.I.\text{Cos}\phi.\text{PTR}.\text{CTR}$$

$$\text{Power} = \frac{\sqrt{3} \times 110 \times 5 \times 1 \times 33 \times 1000 \times 500}{110 \times 5}$$

$$= 28.578 \times 10 = 28.578 \text{MW}$$

Maximum upper limit in this case should be 25MW or 30MW.

Ordering Information

Please give the following details while ordering :

Model : _____
Full Scale Range : _____
CTR : _____
Voltage (Ph-Ph or Ph-N) : _____
PTR (if any) : _____
Connection diagram number : _____

Example :

Model : 96QW32
Full Scale Range : 0-6 MW
CTR : 600/5A
Voltage Ph-Ph : 110V AC
PTR : 6.6KV/110V
Connection diagram number : 4

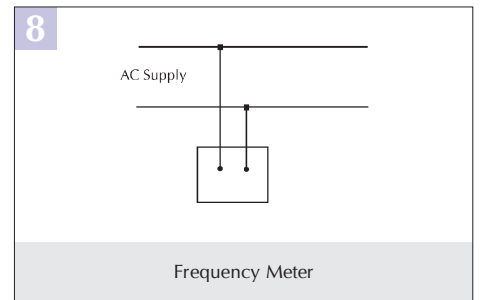
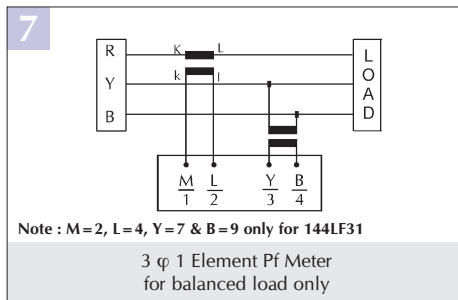
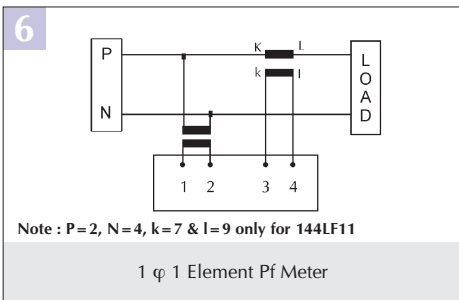
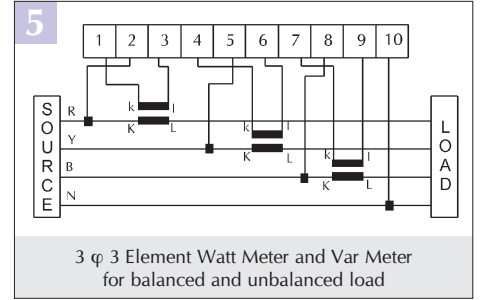
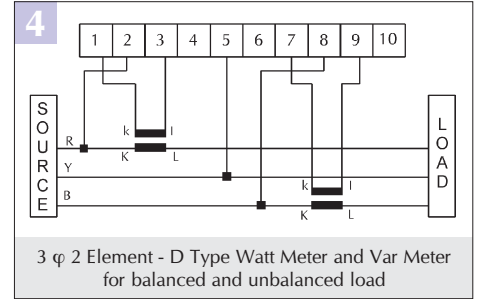
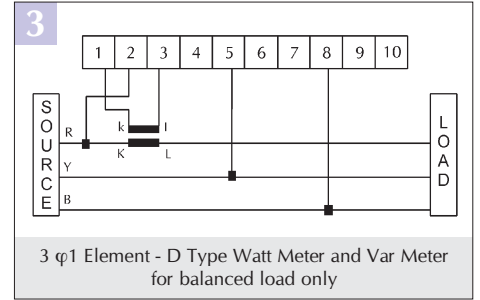
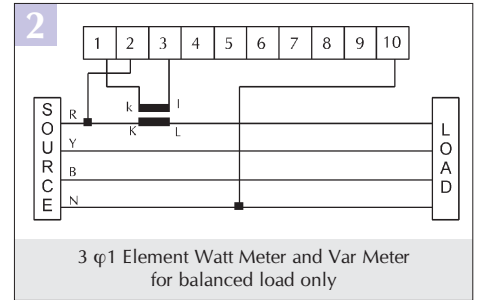
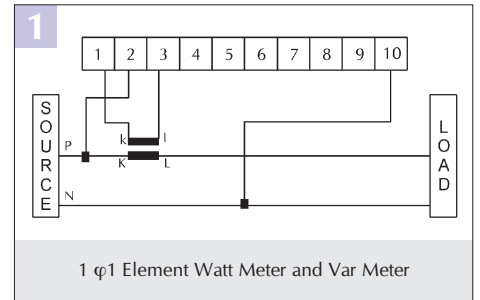



Interchangeable Scale

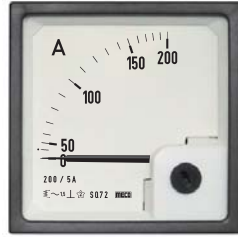

SQ72

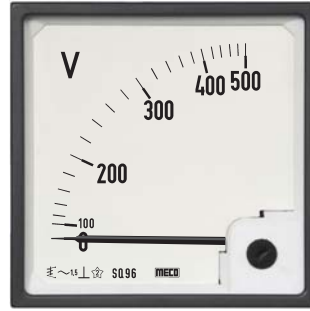

SQ96

Model

Description
Movement Type
Accuracy
Self Consumption
Operating Voltage
Test Voltage
Construction & Design
Scale
Case/Housing Material
Bezel
Glass Faceplate
Mounting Fasteners/Clamps

Temperature Conditions

Front Protection

Terminal Protection

SQ72, SQ96

Moving iron meter of 90° deflection with interchangeable scale facility
Moving iron spring-mounted jewel bearing suspension
± 1.5% of full scale as per IS 1248; EN 60051
Ammeters (upto 5A AC) ≤ 0.6VA; Voltmeters (upto 500V AC) ≤ 5VA
600V RMS max.
2.5KV for 1 minute at 50 Hz
According to IS 1248; EN 60051
According to DIN 43802
White ABS, dimensions as per DIN 43700
Black ABS, dimensions as per DIN 43718
Flat Glass
Ergonomic easy mountable clamps and nuts for easy installation on Switchboards, Panels, Mosaics etc.
- 10°C to + 55°C, RH < 90% (Operating) and
- 20°C to + 70°C, RH < 90% (Storage) EN60051
IP52 protection as per IS2147. IP54 (optional)
Back cover for IP20 terminal protection as per IS2147 (optional)

Dimension and Panel Cutout						
— Optional Terminal Protection Cover						
Model	Dimensions (mm)					
	A	B	C	D	E	F
SQ72 Voltmeter & Ammeter upto 20A	72	67	17	51.5	68	21
SQ72 Ammeter above 20A	72	67	23	51.5	68	-
SQ96 Voltmeter & Ammeter upto 20A	96	90	17	51.5	92	21
SQ96 Ammeter above 20A	96	90	23	51.5	92	-

Ammeters						Voltmeters			
1 x In (A)		2 x In (A)		6 x In (A)		with PT			
Direct	with CT	Direct	with CT	Direct	with CT	Direct	Ratio and Scale		
1A	CTR/5A	1/2A	CTR/5A	1/6A	CTR/5A	50V	PTR/63.5V		
5A	CTR/1A	5/10A	CTR/1A	5/30A	CTR/1A	60V	PTR/110V	10KV/—	
10A	10/—	10/20A	10/20/—	10/60A	10/60/—	75V	PTR/230V	15KV/—	
15A	15/—	15/30A	15/30/—	15/90A	15/90/—	100V	PTR/250V	20KV/—	
20A	20/—	20/40A	20/40/—	20/120A	20/120/—	110V	PTR/400V	25KV/—	
25A	25/—	25/50A	25/50/—	25/150A	25/150/—	150V	PTR/440V	30KV/—	
30A	30/—	30/60A	30/60/—	30/180A	30/180/—	250V		40KV/—	
40A	40/—	40/80A	40/80/—	40/240A	40/240/—	300V	1KV/—	50KV/—	
50A	50/—	50/100A	50/100/—	50/300A	50/300/—	500V	1.2KV/—	60KV/—	
60A	60/—	60/120A	60/120/—	60/360A	60/360/—	600V	1.5KV/—	75KV/—	
75A	75/—	75/150A	75/150/—	75/450A	75/450/—	750V	2KV/—	80KV/—	
80A	100/—	80/160A	100/200/—	80/480A	100/600/—		2.5KV/—	100KV/—	
100A	150/—	100/200A	150/300/—	100/600A	150/900/—		3KV/—	and higher	
	250/—		250/500/—		250/1500/—		3.5KV/—		
	400/—		400/800/—		400/2400/—		4KV/—		
	500/—		500/1000/—		500/3000/—		5KV/—		
	600/—		600/1200/—		600/3600/—		6KV/—		
	1000/—		1000/2000/—		1000/6000/—		7.5KV/—		
	1500/—		1500/3000/—		1500/9000/—		8KV/—		
	and higher		and higher		and higher				

Ordering Information : Model, Input Range, CTR/PTR, Scale

Notes

- a) Double stamping / non-standard marking available.
- b) Gaskets (optional) for vibration proof available.
- c) Terminal protection cover (optional) on request for Voltmeter & Ammeter upto 20 A.
- d) AC instruments calibrated @ 50Hz. (400Hz on request.)
- e) Other ranges subject to technical feasibility.

Wiring Diagram

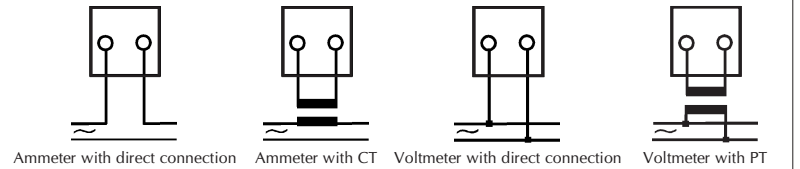

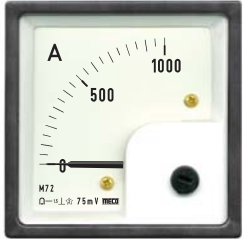

M72, M96



ML72, ML144



ML96



ML110

Model	M72, M96	ML72, ML144	ML72, ML96, ML144, ML110
Description	Full Scale deflection 90°	Full Scale deflection 90°	Full Scale deflection 240°
Movement Type	Moving-coil with central magnetic Core; spring-mounted bearing jewel suspension	Moving-coil with central magnetic Core; spring-mounted bearing jewel suspension	Moving-coil with central magnetic Core; spring-mounted bearing jewel suspension
Accuracy	± 1.5% of Full Scale	± 1.5% of Full Scale	± 1.5% of Full Scale for ML96, ML144, ML110 + 2.5% of Full Scale for ML72
Sensitivity	1000Ω/V (Voltmeter); 200Ω/V (Ammeter)	1000Ω/V (Voltmeter); 200Ω/V (Ammeter)	1000Ω/V (Voltmeter); 200Ω/V (Ammeter)
Operating Voltage	600 V RMS max.	600 V RMS max.	600 V RMS max.
Test Voltage	2.5 KV for 1 minute at 50 Hz	2.5 KV for 1 minute at 50 Hz	2.5 KV for 1 minute at 50 Hz
Construction & Design	According to IS 1248; EN 60051	According to IS 1248; EN 60051	According to IS 1248; EN 60051
Scale	According to DIN 43802	According to DIN 43802	According to DIN 43802
Casing	Size 72, 96 ABS Case with Glass Front	Size 72, 96 ABS Case with Glass Front	Size 72, 96, 144 ABS Case with Glass Front Size 110 ABS Case with Clear Polycarbonate Cover
Dimensions and Panel cutout	Refer Dimensions Page Overleaf		Refer Dimensions Page Overleaf

Ammeters				Voltsmeters	
μA	mA	A*	On shunt	mV	V
	1 mA	1 A	—A/60mV		1 V
	1.5 mA	1.5 A	—A/75 mV		1.5 V
	2 mA	2 A	—A/100 mV		2 V
	2.5 mA	2.5 A			2.5 V
	4 mA	4 A			4 V
	5 mA	5 A	5A/75 mV		5 V
	6 mA	6 A	6A/75 mV		6 V
	10 mA	10 A	10A/75 mV		10 V
	15 mA	15 A	15A/75 mV		15 V
	20 mA	20 A	20A/75 mV		20 V
	25 mA	25 A	25A/75 mV		25 V
	30 mA	30 A	30A/75 mV		30 V
	40 mA	40 A	40A/75 mV		40 V
	50 mA	50 A	50A/75 mV	50 mV	50 V
	60 mA		60A/75 mV	60 mV	60 V
	75 mA		75A/75 mV	75 mV	75 V
100 μA	100 mA		100A/75 mV	100 mV	100 V
150 μA	150 mA		150A/75 mV	150 mV	150 V
250 μA	250 mA		250A/75 mV	250 mV	250 V
400 μA	400 mA		400A/75 mV	400 mV	400 V
500 μA	500 mA		500A/75 mV	500 mV	500 V
600 μA	600 mA		600A/75 mV	600 mV	600 V
800 μA	800 mA		800A/75 mV and higher	800 mV	800 V
					1000 V

Ordering Information : Model, Input Range, Scale

Notes

- Ranges common to M and ML Series
- All other refer to M Series only
- * For ML72 DC direct current upto 1A. Above 1A use with external shunt.
- a) Double stamping / non-standard / centre zero marking available.
- b) Zero supp. DC ammeter for 4-20mA & voltmeter for 5-10V available.
- c) Voltmeters with sensitivity 10K Ohms / V available in 90°
- d) Rubber gaskets for vibration proof available.
- e) Other ranges subject to technical feasibility.

Wiring Diagram

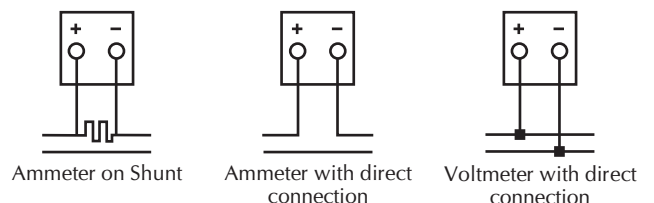



C72, C96



MLC72, MLC144



MLC96



MLC110

Model	C72, C96	MLC72, MLC144, MLC96, MLC110
Description	Moving Coil measuring instruments with AC rectifier; Full Scale deflection 90°	Moving coil measuring instruments with AC rectifier; Full Scale deflection 240°
Movement Type	Moving-coil with central magnetic Core; spring-mounted bearing jewel suspension	Moving-coil with central magnetic Core; spring-mounted bearing jewel suspension
Accuracy	± 1.5% of Full Scale	± 1.5% of Full Scale for MLC96, MLC144, MLC110 ± 2.5% of Full Scale for MLC72
Operating Voltage	600 V RMS max.	600 V RMS max.
Test Voltage	2.5 KV for 1 minute at 50 Hz	2.5 KV for 1 minute at 50 Hz
Self-Consumption	< 1 VA	< 1 VA
Frequency Range	45 Hz to 1 KHz (Voltmeter & Ammeter) 1 KHz to 10KHz (Voltmeter - Optional)	45 Hz to 1 KHz (Voltmeter & Ammeter) 1 KHz to 10KHz (Voltmeter - Optional)
Construction & Design	According to IS 1248; EN 60051	According to IS 1248; EN 60051
Scale	According to DIN 43802	According to DIN 43802
Casing	Size 72, 96 ABS Case with Glass Front	Size 72, 96, 144 ABS Case with Glass Front Size 110 ABS Case with Clear Polycarbonate Cover
Dimensions and Panel cutout	Refer Dimensions Page Overleaf	

Ammeters @						Voltmeters		
1 x In (A)		2 x In (A)		6 x In (A)		On PT		
Direct	On CT	Direct	On CT	Direct	On CT	Direct	Ratio and Scale	
1A	(-)	1/2 A	(-)	1/6 A	(-)	10 V	-V/63.5 V	10 KV
5A	(5A or 1A)	5/10A	(5A or 1A)	5/30 A	(5A or 1A)	15 V	-V/110 V	15 KV
	10/-		10/20/-		10/60/-	20 V	-V/230 V	20 KV
	15/-		15/30/-		15/90/-	25 V	-V/250 V	25 KV
	20/-		20/40/-		20/120/-	30 V	-V/400 V	30 KV
	25/-		25/50/-		25/150/-	40 V	-V/440 V	40 KV
	30/-		30/60/-		30/180/-	50 V	1 KV	50 KV
	40/-		40/80/-		40/240/-	60 V	1.2 KV	60 KV
	50/-		50/100/-		50/300/-	75 V	1.5 KV	75 KV
	60/-		60/120/-		60/360/-	100 V	2 KV	100 KV
	75/-		75/150/-		75/450/-	150 V	2.5 KV	
	100/-		100/200/-		100/600/-	250 V	3 KV	
	150/-		150/300/-		150/900/-	400 V	3.5 KV	
	250/-		250/500/-		250/1500/-	500 V	4 KV	
	400/-		400/800/-		400/2400/-	600 V	5 KV	
	500/-		500/1000/-		500/3000/-	750 V	6 KV	
	600/-		600/1200/-		600/3600/-	800 V	7.5 KV	
	1000/-		1000/2000/-		1000/6000/-	1000 V	8 KV	
	1500/-		1500/3000/-		1500/9000/-			
	and higher		and higher		and higher			

Ordering Information : Model, Input, CTR/PTR, Scale

Notes

- a) Double stamping / non-standard marking available.
 - b) Rectifier type meters calibrated for AC sine wave.
 - c) Rubber gaskets for vibration proof available.
 - d) AC instruments normally calibrated at 50 Hz.
 - e) Other ranges available subject to technical feasibility.
- @ From 1mA to 750mA are also available

Wiring Diagram

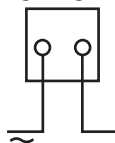

Ammeter (direct)

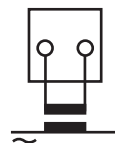

Ammeter on CT

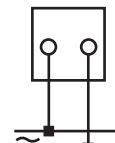

Voltmeter (direct)

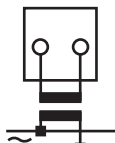

Voltmeter on PT

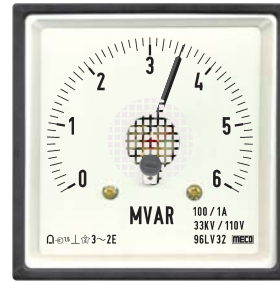
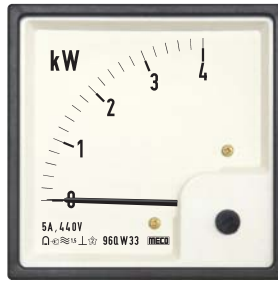

- Rated Accuracy** : ± 1.5% of F.S. for Watt & Var Meter (standard)
 ± 1.0% of F.S. for Watt & Var Meter (optional)
 ± 2° Phase Angle for Powerfactor Meter
 ± 1% of Full Scale for Frequency Meter
- Test Voltage** : 2.5KVAC for 1 min. @ 50 Hz, 4KV AC (optional)
- Insulation Resistance** : Over 20MΩ at 500V DC
- Power Supply** : Self-Powered
- Casing** : Size 72, 96, 144 ABS Case with Glass Front
 Size 110 ABS Case with Clear Polycarbonate Cover
- Continuous Over Load** : 1.2 Times Rated Current / Voltage

Deflection			90°			240°			
Size in mm			72x72	96x96	144x144	72x72	96x96	110x110	144x144
Scale Length (mm)			60	90	140	110	155	175	230
System	Current Range (Amp)	Voltage Range (Volt)							
Watt Meters & Var Meters			Model Codes						
1 Phase 1 Element	1,5,10	63.5, 230	*72QW11 *72QV11	96QW11 96QV11	144QW11 144QV11	*72LW11 *72LV11	96LW11 96LV11	*110LW11 *110LV11	144LW11 144LV11
3 Phase 1 Element Balanced Load only	1,5,10	110, 440	*72QW31 *72QV31	96QW31 96QV31	144QW31 144QV31	*72LW31 *72LV31	96LW31 96LV31	*110LW31 *110LV31	144LW31 144LV31
3 Phase 2 Element [3 Wire] Balanced or Unbalanced Load	1, 5	110, 440	*72QW32 *72QV32	96QW32 96QV32	144QW32 144QV32	*72LW32 *72LV32	96LW32 96LV32	*110LW32 *110LV32	144LW32 144LV32
3 Phase 3 Element [4 Wire] Balanced or Unbalanced Load	1, 5	110/√3 440/√3	*72QW33 *72QV33	96QW33 96QV33	144QW33 144QV33	*72LW33 *72LV33	96LW33 96LV33	*110LW33 *110LV33	144LW33 144LV33
Powerfactor & Phase Angle Meter									
Single Phase	1, 5	63.5, 230	#72QF11	96QF11	144QF11	#72LF11	96LF11	110LF11	144LF11
3 Phase Balanced Load	1, 5	110, 440	#72QF31	96QF31	144QF31	#72LF31	96LF31	110LF31	144LF31
Frequency Meter									
40 - 60 Hz, 45 - 55 Hz, 45 - 65 Hz, 47 - 53 Hz, 55 - 65 Hz, 80 - 120 Hz, 360 - 440 Hz	NA	63.5, 110, 240, 440	F72	F96	F144	#FL72	FL96	FL110	FL144

Notes

- * These Meters supplied with DIN Series Power Line Transducers. # These Meters Supplied with External Box.
- Meters with Dual scale / Tripple scale stamping can be supplied. ● Rubber Gaskets for vibration protection available on request.
- Meters with centre zero or offset zero scale can be supplied. ● Other Voltage and Current ranges available subject to technical feasibility.

Ordering Information : Model, Input Voltage, Input Current, CTR / PTR, Scale, Accuracy Class



MR60, CR60

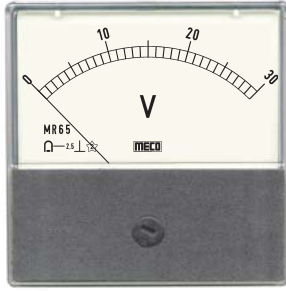

MR65, CR65

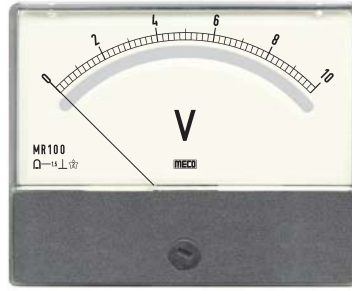

MR100, CR100



MR120, CR120

<p>Model Description Movement Type Accuracy Sensitivity Operating Voltage Test Voltage Frequency Construction & Design Scale Casing Dimensions and Panel cutout</p>	<p>MR60, MR65, MR100, MR120 DC Ammeters and Voltmeters full scale deflection 90° Moving coil, central magnetic core, spring mounted bearing jewel suspension ± 1% of Full Scale for MR120 ± 1.5% of Full Scale for MR100 ± 2.5% of Full Scale for MR60, MR65 1000Ω/V (Voltmeter); 200Ω/V (Ammeter) 600 V RMS max. 2.5 KV for 1 minute at 50 Hz — According to IS 1248; EN 60051 According to DIN 43802 ABS case with Clear Polycarbonate Cover Refer Dimensions Page Overleaf</p>	<p>CR60, CR65, CR100, CR120 AC Ammeters and Voltmeters full scale deflection 90° Moving coil, central magnetic core, spring mounted bearing jewel suspension with rectifier circuit. ± 1.5% of Full Scale for CR100, CR120 ± 2.5% of Full Scale for CR60, CR65 — 600 V RMS max. 2.5 KV for 1 minute at 50 Hz 45Hz to 1KHz (Volt), 45-100Hz (Amp) According to IS 1248; EN 60051 According to DIN 43802 ABS case with Clear Polycarbonate Cover Refer Dimensions Page Overleaf</p>
----------------------------------------------------------------------------------------------------------------------------------------------------------------------------------------------------------------------------	----------------------------------------------------------------------------------------------------------------------------------------------------------------------------------------------------------------------------------------------------------------------------------------------------------------------------------------------------------------------------------------------------------------------------------------------------------------------------------------------------------------------------------------------	------------------------------------------------------------------------------------------------------------------------------------------------------------------------------------------------------------------------------------------------------------------------------------------------------------------------------------------------------------------------------------------------------------------------------------------------------------------------------------------------------------------------------------------

DC Ranges : MR Series

Ammeters *				Voltmeters				
μA	mA		A*	On Shunt		mV	V	
	1 mA	50 mA	1 A	—A/60 mV	50A/75 mV	50 mV	1 V	50 V
	1.5 mA	60 mA	1.5 A	—A/75 mV	60A/75 mV	60 mV	1.5 V	60 V
	2 mA	75 mA	2 A	—A/100 mV	75A/75 mV	75 mV	2 V	75 V
100 μA	2.5 mA	100 mA	2.5 A		100A/75 mV	100 mV	2.5 V	100 V
150 μA	4 mA	150 mA	4 A		150A/75 mV	150 mV	4 V	150 V
250 μA	5 mA	250 mA	5 A	5A/75 mV	250A/75 mV	250 mV	5 V	250 V
400 μA	6 mA	400 mA	6 A	6A/75 mV	400A/75 mV	400 mV	6 V	400 V
500 μA	10 mA	500 mA	10 A *	10A/75 mV	500A/75 mV	500 mV	10 V	500 V
600 μA	15 mA	600 mA	15 A	15A/75 mV	600A/75 mV	600 mV	15 V	600 V
	20 mA		20 A	20A/75 mV			20 V	
	25 mA		25 A	25A/75 mV			25 V	
	30 mA		30 A	30A/75 mV			30 V	
	40 mA		40 A	40A/75 mV			40 V	
			50 A					

* MR60 direct upto 10A DC only. Above 10A use with external shunt.

AC Ranges : CR Series

Ammeters @						Voltmeters					
1 x In (A)		2 x In (A)		6 x In (A)		On PT					
Direct	On CT	Direct	On CT	Direct	On CT	Direct	Ratio and Scale				
	(/-) (5A or 1A)		(/-) (5A or 1A)		(/-) (5A or 1A)			-V/63.5 V			
1 A	10/-	1/2 A	10/20/-	1/6 A	10/60/-	10 V	100 V	-V/110V	2 KV	10 KV	
5 A	15/-	5/10 A	15/30/-	5/30 A	15/90/-	15 V	150 V	-V/230 V	2.5 KV	15 KV	
	20/-		20/40/-		20/120/-	20 V	250 V	-V/250 V	3 KV	20 KV	
	25/-		25/50/-		25/150/-	25 V	400 V	-V/400 V	3.5 KV	25 KV	
	30/-		30/60/-		30/180/-	30 V	500 V	-V/440 V	4 KV	30 KV	
	40/-		40/80/-		40/240/-	40 V	600 V		5 KV	40 KV	
	50/-		50/100/-		50/300/-	50 V		1 KV	6 KV	50 KV	
	60/-		60/120/-		60/360/-	60 V		1.2 KV	7.5 KV	60 KV	
	75/-		75/150/-		75/450/-	75 V		1.5 KV	8 KV	75 KV	
	and higher		and higher		and higher						

@ From 100mA to 5A AC, use with External CT Box, supplied with the instrument.

Ordering Information : Model, Input range, Scale

Notes	
a) Double stamping /non-standard / centre zero marking available.	b) Zero suppressed DC ammeter for 4-20mA and voltmeter for 5-10V available.
c) DC Voltmeters with sensitivity 10 K Ohms / V available.	d) Other ranges available subject to technical feasibility.

Moving Coil Educational Desk Stand Meters

MECO Educational Desk Stand Meters are ideal for laboratory use. These meters are made of an unbreakable ABS desk stand with two or three terminals and fitted with MR65, MR100, CR65 or CR100 meters.



MR65EDM



MR100EDM

Model	MR65EDM (DC)	MR100EDM (DC)
Accuracy	± 2.5% of Full Scale	± 1.5% of Full Scale
Scale Length	68mm	80mm

Ranges	MR65EDM / MR100EDM
Microamps	0-100 μ A to 0-1000 μ A
Milliamps	0-1mA to 0-1000mA
Amps	0-1A to 0-30A
Millivolts	0-50mV to 0-1000mV
Volt	0-1V to 0-1000V
Galvanometer	30-0-30 G or 50-0-50 G with 2 μ A/Div or 20 μ A/Div

Note : Dual ranges available subject to technical feasibility.



CR65EDM



CR100EDM

Model	CR65EDM (AC)	CR100EDM (AC)
Accuracy	± 2.5% of Full Scale	± 1.5% of Full Scale
Scale Length	68mm	80mm

Ranges	CR65EDM / CR100EDM
Microamps	—
Milliamps	0-1mA to 0-1000mA
Amps	0-1A to 0-5A
Millivolts	—
Volt	0-10V to 0-1000V
Galvanometer	—

Dimension (mm)

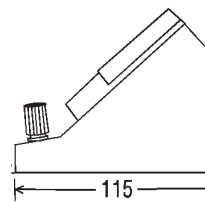
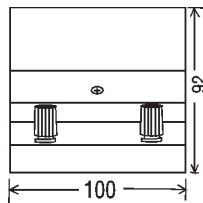

Moving Coil Panel Meters

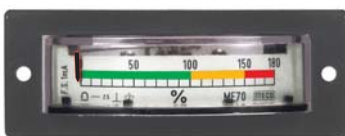

DC : ME70, AC : CE70

- Casing : Clear transparent Polycarbonate Cover
- Accuracy : ± 2.5% of Full Scale
- Ranges & details : Similar to models MR60 and CR60, Current Range max. 1.5 A
- Scale Length : 52mm

Dimensions (mm)

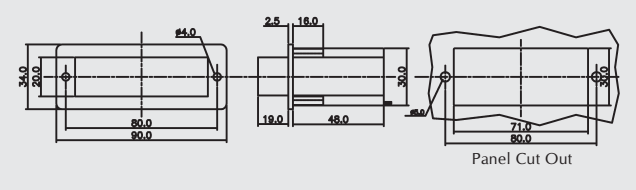

MECO®

SINCE 1962

Testing & Measuring Instruments

- Digital Multimeters
- Digital Clampmeters



Reliable, Long-Lasting and Affordable Instruments ...since 1962 !

www.mecoinst.com

An ISO 9001-2008 Certified Company

MECO INSTRUMENTS PRIVATE LTD.

NAVI MUMBAI



65P

Features

- 6½ Digit Display (11,99,999 counts)
- 12 Different Measurement Capabilities : DCV / ACV, DCI / ACI, Ω2W / Ω4W, Frequency / Period, Diode Test, Continuity, dB/dBm
- High brightness vacuum fluorescent display
- True-rms AC voltage and current measurement, bandwidth up to 300kHz
- DCV measurement accuracy up to 0.0035%, resolution up to 0.1µV
- Max. measurement rate : 1000 meas/sec
- Equal accuracy frequency measurement up to 1.1MHz
- Relative mode (REL) to eliminate residual reading
- 2 W, 4W resistance measurement mode selectable
- Built-in mX + b, %, dB, dBm etc mathematics calculation function
- 512 readings storage and MAX/MIN/AVER/STD statistics
- HI/IN/LO comparator function
- USB and RS-232 Interfaces provide easy system communication
- Calibration without opening the case
- 10 sets of multimeter setup can be stored and loaded

The 6½ Digit Multimeter can test voltage / current / resistance fast and accurately. The concise design of front panel makes it easier to locate and select the measurement function. Adopts special input overload protect circuit which can stand 1500V voltage between input and ground. When over loaded, it can recover fast so as to ensure the safety and reliability of the equipment.

Many new technologies such as high speed low noise 26 bits A/D converter which gives the good linear and low noise performances. Fast response servo amplifier, floating power source and low offset buffer amplifier constitute front end of servo so as to remove the traditional attenuation, reduce offset drifting as well as to increase measurement rate. The SMD in the multimeter reduces the system density and volume.

Standard USB & RS-232 interface with protocol provided is used with for easy communication, data analysis and statistics as well as construction of an automatic measurement system. The system accepts SCPI (standard commands for programmable instrument) command sets. It is compatible in communication software.

Test Function

Test Parameter	DCV, ACV, DCI, ACI, Ω2W, Ω4W, FREQ, PERI, CONT, DIODE
Mathematics Function	mX + b, %, dB, dBm, REL
Range	Auto, Manual
Display	VFD
Trigger Mode	INT/MAN/BUS/EXT
Programmable Time Delay	0-6000mS
Reading Storage and Statistics	2 to 512 readings can be stored, loaded and counted / type of statistics : MAX/MIN/AVER/STD
Reading Hold	To find out best stable reading for each data block of the given reading number according to the given accuracy.
Limitation Measurement	To judge HI/IN/LO and display with ALARM for HI/LO
Setup Storage	10 setup files can be stored and loaded
Communication Interface	SCPI command support for RS232 & USB interface

Measurement Condition

Calibration Interval : One Year
 Operation Temperature : 18°C to 28°C
 Accuracy is expressed as : ± (% of reading + % of range) after 30 min warm-up

Temperature coefficient : Add ± [0.1% x (applicable accuracy)/°C] for 0°C to 18°C & 28°C to 40°C
 Relative Humidity : Upto 80% for 0°C to 28°C (75% RH for 10MΩ & above ranges of resistance measurement). Upto 70% for 28°C to 40°C

Following is the specification at slow mode, others please refer the operation manual.

Full Scale Reading Digits and Reading Rate (meas/sec)				
Rate		Slow	Med	Fast
Full scale reading (digits)		119,999,9	119,999	11,999
Reading Rate (meas/sec) approximate	DCV, DCI	2	16	57
	ACV, ACI	1.5	4	25
	Ω2W Ranges below 100KΩ	2	16	57
	Ω4W Ranges below 100KΩ	1.5	10	33

Accessories	Pair of Test Leads x 1, Power Cord x 1, Fuse (500mA) x 2, Fuse (1A) x 2, USB Cable x 1, Operation Manual x 1, Test Report x 1, RS232 Cable x 1 (optional)
--------------------	-----------------------------------------------------------------------------------------------------------------------------------------------------------

DC V		Max. reading	Resolution	Accuracy	Input impedance
	100mV	119.9999	0.1μV	0.0065+0.0045	> 10GΩ
	1V	1.199999	1μV	0.0040+0.0009	> 10GΩ
	10V	11.99999	10μV	0.0035+0.0005	> 10GΩ
	100V	119.9999	100μV	0.0045+0.0006	10MΩ ± 1%
	1000V	1010.000	1mV	0.0055+0.0015	10MΩ ± 1%

DC I		Max. reading	Resolution	Accuracy	Burden voltage / shunt resistor
	10mA	11.99999	10nA	0.05+0.004	<0.15V/10.1Ω
	100mA	119.9999	0.1μA	0.05+0.004	< 1.5V/10.1Ω
	1A	1.199999	1μA	0.08+0.004	<0.3V/0.1Ω
	10A	11.99999	10μA	0.25+0.015	<0.15V/10mΩ

AC V	100mV	1V	10V	100V	750V
Max. reading	119.9999	1.199999	11.99999	119.9999	757.50
Resolution	0.1μV	1μV	10μV	100μV	1mV
10Hz ~ 20Hz	1.50+0.20				
20Hz ~ 40Hz	0.50+0.10				
40Hz ~ 100Hz	0.10+0.03				
100Hz ~ 20KHz	0.05+0.03			0.08+0.03	
20KHz ~ 50KHz	0.15+0.05	0.11+0.05		0.18+0.05	--
50KHz ~ 100KHz	0.60+0.08				
100KHz ~ 300KHz	4.00+0.50			--	--

AC I	10mA	1A	10A
Max. reading	11.99999	1.199999	11.99999
Resolution	10nA	1μA	10μA
10Hz ~ 20Hz	1.50+0.10		
20Hz ~ 40Hz	0.50+0.03		
40Hz ~ 100Hz	0.10+0.03	0.12+0.03	0.15+0.03
100Hz ~ 2KHz	0.05+0.03	0.10+0.04	0.12+0.04
2KHz ~ 5KHz	0.10+0.03	0.50+0.03	0.60+0.05
5KHz ~ 10KHz	0.20+0.03	2.00+0.10	2.50+0.10
Burden voltage / shunt resistor	<0.15Vrms/10.1Ω	<0.3Vrms/0.1Ω	<0.15Vrms/10mΩ

Frequency	Max. reading	Resolution	Accuracy	Sensitivity (sine wave)
5Hz ~ 10Hz	9.999,999	1μHz	0.05	200mVrms
10Hz ~ 100Hz	99.999,99	10μHz	0.01	40mVrms
100Hz ~ 100KHz	99.999,99	10mHz	0.005	40mVrms
100KHz ~ 1MHz	999.999,9	0.1Hz	0.005	100mVrms

Ω 2W / Ω 4W	Max. reading	Resolution	Measurement current	Accuracy
100Ω	119.9999	100μΩ	1mA	0.010+0.004
1kΩ	1.199999	1mΩ	1mA	0.010+0.001
10kΩ	11.99999	10mΩ	100μA	0.010+0.001
100kΩ	119.9999	100mΩ	10μA	0.010+0.001
1MΩ	1.199999	1Ω	10μA	0.010+0.001
10MΩ	11.99999	10Ω	7.0xRx/(10M+Rx)	0.040+0.001
100MΩ	119.9999	100Ω	7.0xRx/(10M+Rx)	0.800+0.010

General Specifications

- Operating Temperature & Humidity 0°C to 40°C, ≤ 90% RH
- Power Requirements Voltage 110V/220V AC ± 15%
- Frequency 50Hz/60Hz ± 5%
- Power Consumption ≤ 20VA
- Dimensions 265 x 105 x 360mm (approx.)
- Weight 2.863kg (approx.)



81-USB

Features

- Auto / Manual
- 4000 Counts LCD
- Basic DC Accuracy : 0.3%
- More than 45 Measuring Ranges
- Frequency Measurement : 10Hz to 4 MHz
- Duty Cycle : 10% ~ 90%
- Resistance : 0.1Ω to 40MΩ
- Capacitance : 4nF to 40μF
- Measures AC Voltage in dBm or Volts
- Data HOLD / MAX / MIN
- Relative Measurement
- Pulse Widths
- Logic Test
- HFE Test
- Diode Test
- Audible Continuity
- Dynamic Recording
- Communication : USB Cable
- Auto Power Off

General Specification

- Power : One 9V Battery
- Weight : 296gms including Battery (approx.)
- Dimension : 178 x 88 x 43mm (approx.)
- Safety / Compliance : IEC 61010 CAT II
- Accessories : Instruction Manual, Pair of Test Leads, Holster, Battery (installed), USB Cable & Software CD

Meter View Software

Display Graphs, Real Time Values, Analog Indication and Digital Values Simultaneously Software has special features like :

- AUTO Amplitude Scale
- AUTO Sample Scale
- DATA Log
- Virtual LCD & Analog Meter

Electrical Specification

Range	Resolution	Accuracy	Note
DC Voltage			
400mV	100μV	± (0.3% rdg + 4 dgt)	Input Impedance : 10MΩ in parallel with < 50 PF Overload Protection 1000V DC / 750V AC
4V	1mV	± (0.5% rdg + 5 dgt)	
40V	10mV		
400V	100mV	± (0.5% rdg + 3 dgt)	
1000V	1V	± (0.5% rdg + 4 dgt)	
AC Voltage, AC Response : 50 ~ 500Hz			
400mV	100μV	± (0.5% rdg + 4 dgt)	Input Impedance : 10MΩ in parallel in parallel with < 50 PF Overload Protection 1000V DC / 750V AC
4V	1mV	± (0.5% rdg + 3 dgt)	
40V	10mV	± (0.8% rdg + 5 dgt)	
400V	100mV	± (0.6% rdg + 3 dgt)	
750V	1V	± (0.8% rdg + 4 dgt)	
DC Current			
400μA	100nA	± (0.8% rdg + 5 dgt)	Fuse : F 500mA / 250V
4mA	1μA	± (0.6% rdg + 3 dgt)	
40mA	10μA		
400mA	100μA	± (1.2% rdg + 5 dgt)	
4A	1mA	± (0.8% rdg + 5 dgt)	Fuse : F 12A / 250V
10A	10mA	± (1.0% rdg + 5 dgt)	
AC Current, AC Response : 50 ~ 500Hz			
400μA	100nA	± (1.0% rdg + 5 dgt)	Fuse : F 500mA / 250V
4mA	1μA		
40mA	10μA	± (1.5% rdg + 5 dgt)	
400mA	100μA		
4A	1mA	± (1.0% rdg + 5 dgt)	Fuse : F 12A / 250V
10A	10mA	± (1.2% rdg + 5 dgt)	
Resistance (Ω)			
400Ω	100mΩ	± (0.4% rdg + 5 dgt)	Overload Protection 250V DC / AC
4KΩ	1Ω		
40KΩ	10Ω	± (0.3% rdg + 3 dgt)	
400KΩ	100Ω		
4MΩ	1KΩ	± (0.6% rdg + 3 dgt)	
40MΩ	10KΩ	± (1.5% rdg + 5 dgt)	
Capacitance			
4nF	1 PF	± (3.0% rdg + 40 dgt)	Overload Protection 250V DC / AC
40nF	10 PF		
400nF	100 PF	± (3.0% rdg + 10 dgt)	
4μF	1 nF		
40μF	10 nF		
Frequency (Hz)			
400Hz	0.1 Hz	± (0.1% rdg + 4 dgt)	OL Protection : 250V DC / AC Sensitivity : 50mV rms (400Hz, 4KHz, 40KHz) 100mV rms (400KHz) 250mV rms (4MHz)
4KHz	1 Hz		
40KHz	10 Hz		
400KHz	100 Hz		
4 MHz	1 KHz		

Range	Accuracy	Note
Duty Cycle, for 10Hz to 100KHz		
10% ~ 90%	± (2 dgt / KHz + 2 dgt)	OL Protection : 250V DC / AC
Pulse Widths, for 10Hz to 100KHz		
1μs ~ 90 ms	± (5% rdg + 2 dgt)	OL Protection : 250V DC / AC
dBm, 20mV to 750V RMS at 50 / 60 Hz		
0 ~ +62dB	± (0.3% dBm + 2 dgt)	OL Protection : 250V DC / AC

Analog & Digital Display

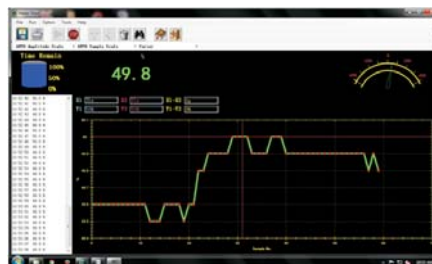

Data Logging / Recording

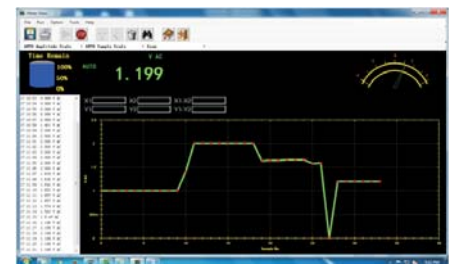



450-TRMS



450TRMS Super



Accessories

4½ Digit, 20,000 Counts, TRMS, Large LCD, Capacitance, Frequency, Data Hold, APO

Ranges

DC Voltage	200mV/2/20/200/1000V
Accuracy	±(0.05%rdg + 3dgt) ±(0.1%rdg + 5dgt) on 1000V
AC Voltage^{TRMS}	200mV/2/20/200/750V
Accuracy	±(0.8%rdg + 20dgt) ±(1.0%rdg + 50dgt) on 750V
AC Response	40 ~ 500Hz
DC Current	20/200mA/10A
Accuracy	±(0.5%rdg + 2dgt) on 20mA ±(0.8%rdg + 5dgt) on 200mA ±(2.0%rdg + 10dgt) on 10A
AC Current^{TRMS}	20/200mA/10A
Accuracy	±(1.0%rdg + 20dgt) on mA ±(2.0%rdg + 20dgt) on 10A
AC Response	40 ~ 500Hz
Resistance	200Ω/2/20/200kΩ/2/20MΩ
Accuracy	±(0.1%rdg + 2dgt) ±(0.1%rdg + 5dgt) on 200Ω ±(0.3%rdg + 10dgt) on 20MΩ
Capacitance	20/200nF/2/20μF
Accuracy	±(2.0%rdg + 10dgt) ±(2.5%rdg + 30dgt) on 20μF
Frequency	20/200kHz
Accuracy	±(1.0%rdg + 20dgt)
Sp. Function	Diode Test, Audible Continuity, Data Hold
Power	One 9V Battery
Low Battery	"" Indicated
Battery Life	150 hours typical
Dimensions	190 x 90 x 35 mm (approx.)
Weight	525gms Including Battery (approx.)
Measuring Category	CAT I 1000V
Accessories	Supplied with Pair of Test Leads, Battery (installed), Instruction Manual & Holster

TRMS, Auto / Manual, 4½ Digit 20,000 Count LCD with Backlight, APO, Capacitance, Frequency, Duty Cycle, Temperature, DATA HOLD, MIN / MAX, Δ ZERO / REL, Diode Test, Audible Continuity & Square Wave Output

DC Voltage	200mV/2/20/200/1000V
Accuracy	±(0.05% rdg + 5 dgt) ±(0.1% rdg + 5 dgt) on 1000V
AC Voltage^{TRMS}	200mV/2/20/200/750V
Accuracy	±(0.5% rdg + 6 dgt) ±(1.0% rdg + 30dgt) on 750V
AC Response	40 ~ 500Hz
DC Current	200/2000μA/20/200mA/2/20A
Accuracy	±(0.5% rdg + 2 dgt) on 200/2000μA ±(0.8% rdg + 5dgt) on 20/200mA ±(2.0% rdg + 10dgt) on 2/20A
AC Current^{TRMS}	200/2000μA/20/200mA/2/20A
Accuracy	±(1.0% rdg + 20 dgt) on μA & mA ±(1.5% rdg + 5 dgt) on 2 / 20A
AC Response	40 ~ 500Hz
Resistance	200Ω/2/20/200kΩ/2/20MΩ
Accuracy	±(0.1% rdg + 5dgt) on 200Ω ±(0.1% rdg + 2 dgt) on 2/20/200kΩ/2MΩ ±(0.3% rdg + 5dgt) on 20MΩ
Capacitance	20/200nF/2/20/200μF/2/20mF
Accuracy	±(2.0% rdg + 10 dgt) on 20 / 200nF / 2μF ±(2.0% rdg + 30 dgt) on 20 / 200μF ±(3.0% rdg + 4 dgt) on 2 / 20mF
Frequency	200Hz / 2 / 20 / 200KHz / 2 / 20MHz

K Type Bead Probe (upto 260°C)
Model : TPK-B



K Type Stick Probe (upto 500°C)
Model : TP-02



Pair of Test Leads suitable for DMM/DTT
Model : TL-DMM/DTT



Pair of Test Leads suitable for Insulation Tester
Model : TL-IT



Accuracy	±(0.01% rdg + 2dgt)
Duty Cycle	0.1% ~ 99.9%
Accuracy	±(0.01% rdg + 2dgt)
Temperature	-20°C ~ 1000°C / 0°F ~ 1832°F
Accuracy	±(1% rdg + 5dgt) on -20°C ~ 400°C ±(1.5% rdg + 15dgt) on 400°C ~ 1000°C ±(0.75% rdg + 5 dgt) on 0°F ~ 750°F ±(1.5% rdg + 15 dgt) on 750°F ~ 1832°F
Sp. Function	Diode Test, Audible Continuity, Data Hold
Power	Two 1.5V 'AA' Battery
Low Battery	'' is indicated
Battery Life	200 hours typical
Dimensions	161 x 86 x 43 mm (approx.)
Weight	250gms Including Battery (approx.)
Accessories	Supplied with Pair of Test Leads, Battery (installed), K Type Thermocouple (upto 260°C), Instruction Manual & Carrying Case



18-TRMS



666TRMS

<p>Auto Ranging, TRMS, 3½ Digit 2,000 Count LCD, Data Hold, Temperature, APO & Holster</p> <p>Ranges</p> <p>DC Voltage 200mV/2/20/200/1000V Accuracy ± (0.5%rdg + 4dgt) on all ranges except ± (0.8%rdg + 4dgt) on 1000V</p> <p>AC Voltage ^{TRMS} 2/20/200/750V Accuracy ± (1.0%rdg + 5dgt) on all ranges except ± (1.2%rdg + 5dgt) on 750V</p> <p>AC Response 40Hz ~ 400Hz</p> <p>DC Current 200/2000µA/20/200mA/2/10A Accuracy ^{TRMS} ± (1.5%rdg + 4dgt)</p> <p>AC Current 200/2000µA/20/200mA/2/10A Accuracy ± (2.0%rdg + 5dgt)</p> <p>AC Response 40Hz ~ 400Hz</p> <p>Resistance 200Ω/2/20/200kΩ/2/20MΩ Accuracy ± (1.0%rdg + 3dgt) on all ranges except ± (2.5%rdg + 3dgt) on 20MΩ</p> <p>Temperature -20°C ~ 750°C / 4°F ~ 1400°F Accuracy ± (1.0%rdg + 10dgt) on -20°C ~ 400°C / -4°F ~ 650°F ± (3.0%rdg + 10dgt) on 401°C ~ 750°C / -651°F ~ 1400°F (with appropriate sensor to be procured separately)</p> <p>Sp. Function Diode Test, Audible Continuity, Data Hold</p> <p>Power One 9V Battery</p>	<p>Auto / Manual, TRMS, 6,600 Counts, APO, Capacitance, Frequency, Duty Cycle, Temp., Diode Test, Audible Continuity & Data Hold</p> <p>Ranges</p> <p>DC Voltage 600mV/6/60/600/1000V Accuracy ± (1.0%rdg + 4dgt) on 600mV ± (0.5%rdg + 2dgt) on 6/60/600V ± (1.0%rdg + 3dgt) on 1000V</p> <p>AC Voltage ^{TRMS} 600mV/6/60/600/750V Accuracy ± (1.0%rdg + 5dgt) on all ranges except ± (1.2%rdg + 5dgt) on 600mV ± (1.5%rdg + 5dgt) on 750V</p> <p>AC Response 40 ~ 500Hz</p> <p>DC Current 600/6000µA/60/600mA/6/20A Accuracy ± (1.0%rdg + 2dgt) on 600/6000µA ± (1.2%rdg + 3dgt) on 60/600mA ± (1.5%rdg + 5dgt) on 6/20A</p> <p>AC Current ^{TRMS} 600/6000µA/60/600mA/6/20A Accuracy ± (1.5%rdg + 5dgt) on 600/6000µA ± (2.0%rdg + 5dgt) on 60/600mA ± (2.5%rdg + 5dgt) on 6/20A</p> <p>Low Battery "⚡" Indicated</p> <p>Battery Life 200 hours typical</p> <p>Dimensions 141 x 77 x 35 mm (approx.)</p> <p>Weight 200gms Including Battery (approx.)</p> <p>Measuring Catagory CAT II 600V</p> <p>Accessories Supplied with Pair of Test Leads, Battery (installed), K Type Thermocouple (upto 260°C), Instruction Manual & Holster</p>	<p>AC Response 40 ~ 500Hz</p> <p>Resistance 600Ω/6/60/600kΩ/6/60MΩ Accuracy ± (1.2%rdg + 2dgt) on 600Ω & 6MΩ ± (1.0%rdg + 2dgt) on 6/60/600kΩ ± (1.5%rdg + 2dgt) on 60MΩ</p> <p>Capacitance 9.999/99.99/999.9nF/9.999/99.99/999.9µF/9.999mF Accuracy ± (2.0%rdg + 4dgt) on all ranges except ± (3.0%rdg + 4dgt) on 9.999mF</p> <p>Frequency 99.99Hz ~ 20.00MHz Accuracy ± (0.05%rdg + 4dgt)</p> <p>Duty Cycle 0.1% ~ 99.9% Accuracy ± (0.05%rdg + 4dgt)</p> <p>Temperature -40°C ~ 1000°C / -40°F ~ 1832°F Accuracy ± (3.0%rdg + 4dgt) on -40°C ~ 0°C / -40°F ~ 32°F ± (1.0%rdg + 3dgt) on 0°C ~ 400°C / 32°F ~ 750°F ± (2.0%rdg + 5dgt) on 400°C ~ 1000°C / 750°F ~ 1832°F</p> <p>Sp. Function Diode Test, Audible Continuity, Data Hold</p> <p>Power Two 1.5V 'AA' Battery</p> <p>Low Battery "⚡" indicated</p> <p>Battery Life 200 hours typical</p> <p>Dimensions 161 x 86 x 43 mm (approx.)</p> <p>Weight 250gms Including Battery (approx.)</p> <p>Measuring Catagory CAT II</p> <p>Accessories Supplied with Pair of Test Leads, Battery (installed), K Type Thermocouple (upto 260°C), Instruction Manual & Carrying Case</p>
-------------------------------------------------------------------------------------------------------------------------------------------------------------------------------------------------------------------------------------------------------------------------------------------------------------------------------------------------------------------------------------------------------------------------------------------------------------------------------------------------------------------------------------------------------------------------------------------------------------------------------------------------------------------------------------------------------------------------------------------------------------------------------------------------------------------------------------------------------------------------------------------------------------------------------------------------------------------------------------------------------------------------------------------------------------------------------------------------------------------------------------------------	---------------------------------------------------------------------------------------------------------------------------------------------------------------------------------------------------------------------------------------------------------------------------------------------------------------------------------------------------------------------------------------------------------------------------------------------------------------------------------------------------------------------------------------------------------------------------------------------------------------------------------------------------------------------------------------------------------------------------------------------------------------------------------------------------------------------------------------------------------------------------------------------------------------------------------------------------------------------------------------------------------------------------------------------------------------------------------------------------------------------------------------------------------------------------------------------------------------------------------------------------------------------------------	---------------------------------------------------------------------------------------------------------------------------------------------------------------------------------------------------------------------------------------------------------------------------------------------------------------------------------------------------------------------------------------------------------------------------------------------------------------------------------------------------------------------------------------------------------------------------------------------------------------------------------------------------------------------------------------------------------------------------------------------------------------------------------------------------------------------------------------------------------------------------------------------------------------------------------------------------------------------------------------------------------------------------------------------------------------------------------------------------------------------------------------------------------------------------------------------------------------------------------------------------------------------



153B+TRMS



171B+TRMS

TRMS, Auto Ranging, 6000 Counts LCD with Backlight, APO, Capacitance, Frequency, Duty Cycle & Holster

Ranges	
DC Voltage	600mV / 6 / 60 / 600 / 1000V
Accuracy	± (1.0% rdg + 4 dgt) on 600mV ± (0.5% rdg + 2 dgt) on 6/60/600V ± (7.0% rdg + 3 dgt) on 1000V
AC Voltage ^{TRMS}	600mV / 6 / 60 / 600 / 750V
Accuracy	± (1.0% rdg + 5 dgt) on all ranges except ± (1.2% rdg + 5 dgt) on 600mV ± (1.5% rdg + 5 dgt) on 750V
AC Response	40 ~ 500Hz
DC Current	600 / 6000µA / 60 / 600mA / 6 / 20A
Accuracy	± (1.0% rdg + 2 dgt) on 600/6000µA ± (1.2% rdg + 3 dgt) on 60/600mA ± (1.5% rdg + 5 dgt) on 6/20A
AC Current ^{TRMS}	600 / 6000µA / 60 / 600mA / 6 / 20A
Accuracy	± (1.5% rdg + 5 dgt) on 600/6000µA ± (2.0% rdg + 5 dgt) on 60/600mA ± (2.5% rdg + 5 dgt) on 6/20A
AC Response	40 ~ 500Hz
Resistance	600Ω / 6 / 60 / 600KΩ / 6 / 60MΩ
Accuracy	± (1.2% rdg + 2 dgt) on 600Ω & 6MΩ ± (1.0% rdg + 2 dgt) on 6/60/600kΩ ± (1.5% rdg + 2 dgt) on 60MΩ
Capacitance	9.999 / 99.99 / 999.9nF / 9.999 / 99.99 / 999.9µF / 9.999mF
Accuracy	± (2.0% rdg + 4 dgt) on all ranges except

TRMS, Auto / Manual, 6000 Counts LCD with Backlight, APO, Capacitance, REL Δ, Max / Min, Frequency, Duty Cycle, Temperature & Holster

Ranges	
DC Voltage	600mV / 6 / 60 / 600 / 1000V
Accuracy	± (1.0% rdg + 4 dgt) on 600mV ± (0.5% rdg + 2 dgt) on 6/60/600V ± (7.0% rdg + 3 dgt) on 1000V
AC Voltage	600mV / 6 / 60 / 600 / 750V
Accuracy	± (1.0% rdg + 5 dgt) on all ranges except ± (1.2% rdg + 5 dgt) on 600mV ± (1.5% rdg + 5 dgt) on 750V
AC Response	40 ~ 500Hz
DC Current	600 / 6000µA / 60 / 600mA / 6 / 20A
Accuracy	± (1.0% rdg + 2 dgt) on 600/6000µA ± (1.2% rdg + 3 dgt) on 60/600mA ± (1.5% rdg + 5 dgt) on 6/20A
AC Current	600 / 6000µA / 60 / 600mA / 6 / 20A

Frequency	± (3.0% rdg + 4 dgt) on 9.999mF 99.99Hz ~ 20.00MHz
Accuracy	± (0.05% rdg + 4 dgt)
Duty Cycle	0.1% ~ 99.9%
Accuracy	± (0.05% rdg + 4 dgt)
Measuring Category	CAT III 1000V, CAT IV 600V
SP Function	Diode test, Audible Continuity, Data Hold
Power	Two 1.5V 'AA' Battery
Low Battery	'' is indicated
Battery Life	200 hours typical
Dimensions	180 x 90 x 52mm (approx.)
Weight	370gms Including Battery (approx.)
Accessories	Test Leads (Pair), Holster, Battery (installed) & Instruction Manual

Accuracy	± (1.5% rdg + 5 dgt) on 600/6000µA ± (2.0% rdg + 5 dgt) on 60/600mA ± (2.5% rdg + 5 dgt) on 6/20A
AC Response	40 ~ 500Hz
Resistance	600Ω / 6 / 60 / 600KΩ / 6 / 60MΩ
Accuracy	± (1.2% rdg + 2 dgt) on 600Ω & 6MΩ ± (1.0% rdg + 2 dgt) on 6/60/600kΩ ± (1.5% rdg + 2 dgt) on 60MΩ
Capacitance	9.999 / 99.99 / 999.9nF / 9.999 / 99.99 / 999.9µF / 9.999mF
Accuracy	± (2.0% rdg + 4 dgt) on all ranges except ± (3.0% rdg + 4 dgt) on 9.999mF
Frequency	99.99Hz ~ 20.00MHz
Accuracy	± (0.05% rdg + 4 dgt)
Duty Cycle	0.1% ~ 99.9%
Accuracy	± (0.05% rdg + 4 dgt)
Temperature	40°C ~ 1000°C / -40°F ~ 1832°F
Accuracy	± (3.0% rdg + 4dgt) on -40°C ~ 0°C / -40°F ~ 32°F ± (1.0% rdg + 3dgt) on 0°C ~ 400°C / 32°F ~ 750°F ± (2.0% rdg + 5dgt) on 400°C ~ 1000°C / 750°F ~ 1832°F
Measuring Category	CAT III 1000V, CAT IV 600V
SP Function	Diode test, Audible Continuity, Data Hold
Power	Two 1.5V 'AA' Battery
Low Battery	'' is indicated
Battery Life	200 hours typical
Dimensions	180 x 90 x 52mm (approx.)
Weight	370gms Including Battery (approx.)
Accessories	Test Leads (Pair), Holster, Battery (installed), Instruction Manual & K Type Thermocouple (upto 260°C)



63





603



45CF

3½ Digit 2,000 Count LCD Audible Continuity, Data Hold Diode, hFE Test & Backlight Display Ranges	
DC Voltage	200mV/2/20/200/1000V
Accuracy	± (0.5%rdg + 1dgt) on all ranges
AC Voltage	200/750V (50-500Hz)
Accuracy	± (1%rdg + 4dgt) on 200V ± (1.5%rdg + 4dgt) on 750V
DC Current	200µA/2mA/20mA/ 200mA/10A
Accuracy	± (1%rdg + 1dgt) on all ranges except ± (2%rdg + 3dgt) on 10A
Resistance	200Ω/2kΩ/20kΩ/200kΩ /2MΩ
Accuracy	± (0.8%rdg + 1dgt) on all ranges, except ± (1%rdg + 3dgt) on 200Ω
Sp. Function	Audible Continuity, Diode Check, hFE Test Data Hold & Backlight Display
Power	One 9V battery
Low Battery	"  " is indicated
Battery Life	200 hours typical
Dimensions	145 x 70 x 35 mm (approx.)
Weight	180gms Including Battery (approx.)
Accessories	Supplied with Pair of Test Leads, Battery (installed), Instruction Manual & Holster

3½ Digit 2,000 Count LCD 17mm Large LCD, Audible Continuity, Diode & hFE Test Ranges	
DC Voltage	200mV/2/20/200/1000V
Accuracy	± (0.5%rdg + 1dgt) on all ranges
AC Voltage	200mV/2/20/200/750V (50-500Hz)
Accuracy	± (1%rdg + 4dgt) on all ranges except ± (1.5%rdg + 4dgt) on 750V
DC Current	200µA/2mA/20mA/ 200mA/20A
Accuracy	± (1%rdg + 1dgt) on all ranges except ± (2%rdg + 3dgt) on 20A
AC Current	200µA/2mA/20mA/ 200mA/20A (50-500Hz)
Accuracy	± (1.2%rdg + 4dgt) on all ranges except ± (2%rdg + 4dgt) on 20A
Resistance	200Ω/2kΩ/20kΩ/200kΩ/ 2000kΩ/20MΩ/200MΩ
Accuracy	± (0.8%rdg + 1dgt) on all ranges, except ± (1%rdg + 3dgt) on 200Ω ± (3%rdg + 3dgt) on 20MΩ ± (5%rdg + 10dgt) on 200MΩ
Sp. Function	Audible Continuity, Diode Check, hFE Test
Power	One 9V battery
Low Battery	"  " is indicated
Battery Life	200 hours typical
Dimensions	170 x 80 x 43mm (approx.)
Weight	240gms Including Battery (approx.)
Accessories	Supplied with Pair of Test Leads, Carrying Case, Battery (installed), Instruction Manual and Spare Fuse

4½ Digit 20,000 Counts, Large LCD, Capacitance, Frequency, hFE, Infrared Remote Control Check, Live Wire Check, APO Ranges	
DC Voltage	200mV/2/20/200/1000V
Accuracy	± (0.05%rdg + 5dgt) on all ranges except ± (0.1%rdg + 5dgt) on 1000V
AC Voltage	200mV/2/20/200/750V
Accuracy	± (0.8%rdg + 10dgt) on all ranges except ± (1.0%rdg + 15dgt) on 750V
DC Current	2mA/20/200mA/20A
Accuracy	± (0.5%rdg + 5dgt) on 2/20mA ± (0.8%rdg + 5dgt) on 200mA ± (2.0%rdg + 10dgt) on 20A
AC Current	20/200mA/20A
Accuracy	± (0.8%rdg + 10dgt) on 20/200mA ± (3%rdg + 10dgt) on 20A
Resistance	200Ω/2/20/200kΩ/2/20MΩ
Accuracy	± (0.4%rdg + 5dgt) on all ranges except ± (0.8%rdg + 5dgt) on 20MΩ
Capacitance	20/200nF/2/200µF
Accuracy	± (3%rdg + 10dgt) on all ranges except ± (5%rdg + 10dgt) on 200µF
Frequency	20kHz
Accuracy	± (1.5%rdg + 5dgt)
Sp. Function	Diode, Continuity, Data Hold, hFE, Capacitance, Hz, Infrared Remote Control Check, Live Wire Check, APO
Power	One 9V battery
Low Battery	"  " Indicated
Battery Life	150 hours typical
Dimensions	182 x 90 x 60 mm (approx.)
Weight	365gms Including Battery (app.)
Accessories	Supplied with Pair of Test Leads, Battery (installed), Inst. Manual & Holster



9A09



9A06

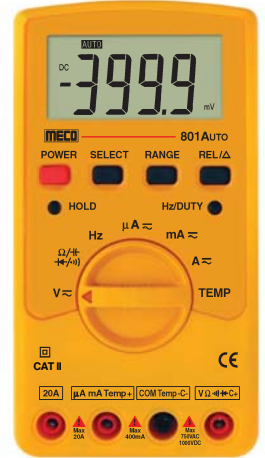

801AUTO

3½ Digit, 2,000 Count LCD, Auto Ranging, Data Hold, Temperature & APO

Ranges

DC Voltage	200mV/2/20/200/600V
Accuracy	± (0.5%rdg + 4dgt) on 200mV & 2V, ± (0.7%rdg + 4dgt) on 20V & 200V, ± (1%rdg + 4dgt) on 600V
AC Voltage	2/20/200/600V
Accuracy	± (1.0%rdg + 8dgt) on all ranges except ± (1.5%rdg + 8dgt) on 600V
DC Current	200/2000µA/20/200mA/2/10A
Accuracy	± (1.5%rdg + 4dgt)
AC Current	200/2000µA/20/200mA/2/10A
Accuracy	± (2.2%rdg + 4dgt)
Resistance	200Ω/2/20/200kΩ/2/20MΩ
Accuracy	± (0.7%rdg + 4dgt) on all ranges except ± (1.2%rdg + 4dgt) on 2MΩ ± (2.5%rdg + 4dgt) on 20MΩ
Temperature	-20°C ~ 1300°C/-4°F ~ 1999°F
Accuracy	± (2%rdg + 4dgt)
Sp. Function	Diode Test, Audible Continuity, Data Hold
Power	Two 1.5V 'AAA' Battery
Low Battery	"" Indicated
Battery Life	200 hours typical
Dimensions	150 x 80 x 33 mm (approx.)
Weight	140gms Including Battery (approx.)
Measuring Category	CAT II
Accessories	Supplied with Pair of Test Leads, Battery (installed), Instruction Manual & Holster Optional : K Type Thermocouple (upto 260°C)

Auto / Manual, 3½ Digit, 2,000 Count LCD, APO & Temperature

Ranges

DC Voltage	200mV/2/20/200/1000V
Accuracy	± (0.5%rdg + 4dgt) on 200mV & 2V, ± (0.7%rdg + 4dgt) on 20V & 200V, ± (1%rdg + 4dgt) on 1000V
AC Voltage	200mV/2/20/200/750V (200mV Manual only)
Accuracy	± (1.0%rdg + 8dgt) on all ranges except ± (1.5%rdg + 8dgt) on 750V
DC Current	200/2000µA/20/200mA/2/10A
Accuracy	± (1.5%rdg + 4dgt)
AC Current	200/2000µA/20/200mA/2/10A
Accuracy	± (2.2%rdg + 4dgt)
Resistance	200Ω/2/20/200kΩ/2/20MΩ
Accuracy	± (0.7%rdg + 4dgt) on all ranges except ± (1.2%rdg + 4dgt) on 2MΩ ± (2.5%rdg + 4dgt) on 20MΩ
Temperature	-20°C ~ 1300°C/-4°F ~ 1999°F
Accuracy	± (2%rdg + 4dgt)
Sp. Function	Diode Test, Audible Continuity, Data Hold
Power	Two 1.5V 'AA' Battery
Low Battery	"" Indicated
Battery Life	200 hours typical
Dimensions	161 x 86 x 43 mm (approx.)
Weight	250gms Including Battery (approx.)
Measuring Category	CAT II
Accessories	Supplied with Pair of Test Leads, Battery (installed), K Type Thermocouple (upto 260°C), Inst. Manual & Carrying Case

Auto / Manual, 3¾ Digit, 4,000 Count LCD, APO, Capacitance, Frequency, Duty Cycle & Temperature

Ranges

DC Voltage	400mV/4/40/400/1000V
Accuracy	± (0.5% rdg + 4 dgt) on 400mV/4V ± (0.7% rdg + 4 dgt) on 40/400V ± (1.0% rdg + 4 dgt) on 1000V
AC Voltage	4/40/400/750V
Accuracy	± (1.0% rdg + 5 dgt) on all ranges except ± (1.5% rdg + 8 dgt) on 750V
DC Current	400/4000µA/40/400mA/4/20A
Accuracy	± (1.5% rdg + 4 dgt)
AC Current	400/4000µA/40/400mA/4/20A
Accuracy	± (2.2% rdg + 4 dgt)
Resistance	400Ω/4/40/400kΩ/4/40MΩ
Accuracy	± (0.7% rdg + 4 dgt) on all ranges except ± (1.2% rdg + 4 dgt) on 4MΩ ± (2.5% rdg + 4 dgt) on 40MΩ
Capacitance	40/400nF/4/40/100µF
Accuracy	± (5.0% rdg + 10 dgt)
Frequency	9.999Hz ~ 9.999MHz
Accuracy	± (0.5% rdg + 2 dgt)
Duty Cycle	0.1% ~ 99.9%
Accuracy	± (0.5% rdg + 2 dgt)
Temperature	-20°C ~ 1300°C
Accuracy	± (2% rdg + 4 dgt)
Sp. Function	Diode Test, Audible Continuity, Data Hold
Power	Two 1.5V 'AA' Battery
Low Battery	"" is indicated
Battery Life	200 hours typical
Dimensions	161 x 86 x 43 mm (approx.)
Weight	250gms Including Battery (approx.)
Measuring Category	CAT II
Accessories	Supplied with Pair of Test Leads, Battery (installed), K Type Thermocouple (upto 260°C), Inst. Manual & Carrying Case



27-AUTO





27T-AUTO



2502T-AUTO

400A AC	
Auto Ranging, 3½ Digit, 2,000 Counts, Data Hold, Max, NCV, APO	
Ranges	
AC Current	2A, 20A, 200A, 400A (Auto Ranging)
Accuracy	± (3%rdg + 5dgt) on 2A ± (2%rdg + 3dgt) on 20A ± (2%rdg + 5dgt) on 200A & 400A
Overload	400A AC max. for 1 min.
AC Voltage	2V, 20V, 200V, 600V (Auto Ranging)
Accuracy	± (1.2%rdg + 3dgt)
DC Voltage	200mV, 2V, 20V, 200V, 600V (Auto Ranging)
Accuracy	± (0.8%rdg + 3dgt)
Resistance	200Ω, 2kΩ, 20KΩ, 200kΩ, 2MΩ, 20MΩ (Auto Ranging)
Accuracy	± (1.2%rdg + 3dgt)
Audible Continuity	40Ω Approx
Diode Test Function	1.0 ± 0.6mA Approx
Power	Two 1.5V 'AAA' Battery
Battery Life	200 Hours Typical
Low Battery	"  " is indicated
Dimension	185 x 65 x 28 mm (approx.)
Weight	170gms Including Battery (approx.)
Accessories	One Pair of Test Leads, Instruction Manual, Carrying Case, Battery (installed)
Jaw Opening	Cable Dia. 25mm (max.)
Safety Standard	CAT II 600V

400A AC	
Auto Ranging, 3½ Digit, 2,000 Counts, Temperature, Data Hold, Max, NCV, APO	
Ranges	
AC Current	2A, 20A, 200A, 400A (Auto Ranging)
Accuracy	± (3%rdg + 5dgt) on 2A ± (2%rdg + 3dgt) on 20A ± (2%rdg + 5dgt) on 200A & 400A
Overload	400A AC max. for 1 min.
AC Voltage	2V, 20V, 200V, 600V (Auto Ranging)
Accuracy	± (1.2%rdg + 3dgt)
DC Voltage	200mV, 2V, 20V, 200V, 600V (Auto Ranging)
Accuracy	± (0.8%rdg + 3dgt)
Temperature	-20°C to 750°C
Accuracy	± (3%rdg + 5dgt)
Resistance	200Ω, 2kΩ, 20KΩ, 200kΩ, 2MΩ, 20MΩ (Auto Ranging)
Accuracy	± (1.2%rdg + 3dgt)
Audible Continuity	40Ω Approx
Diode Test Function	1.0 ± 0.6mA Approx
Power	Two 1.5V 'AAA' Battery
Battery Life	200 Hours Typical
Low Battery	"  " is indicated
Dimension	185 x 65 x 28 mm (approx.)
Weight	170gms Including Battery (approx.)
Accessories	One Pair of Test Leads, Instruction Manual, Carrying Case, Battery (installed) K Type Thermocouple (upto 260°C)
Jaw Opening	Cable Dia. .25mm (max.)
Safety Standard	CAT II 600V

1000A AC	
Auto / Manual, 3½ Digit, 2,000 Counts, Temperature, Data Hold, Max, NCV, APO	
Ranges	
AC Current	2A, 20A, 200A, 1000A
Accuracy	± (3%rdg + 5dgt) on 2A & 20A ± (2%rdg + 5dgt) on 200A & 1000A
Overload	1000A AC max. for 1 min.
AC Voltage	2V, 20V, 200V, 750V
Accuracy	± (1.2%rdg + 3dgt)
DC Voltage	200mV, 2V, 20V, 200V, 1000V
Accuracy	± (0.8%rdg + 3dgt)
Temperature	-20°C to 750°C
Accuracy	± (3%rdg + 5dgt)
Resistance	200Ω, 2kΩ, 20KΩ, 200kΩ, 2MΩ, 20MΩ
Accuracy	± (1.2%rdg + 3dgt)
Audible Continuity	30Ω Approx
Diode Test Function	1.0 ± 0.6mA Approx
Power	Two 1.5V 'AA' Battery
Battery Life	200 Hours Typical
Low Battery	"  " is indicated
Dimension	245 x 95 x 35 mm (approx.)
Weight	309gms Including Battery (approx.)
Accessories	One Pair of Test Leads, Instruction Manual, Carrying Case, Battery (installed) K Type Thermocouple (upto 260°C)
Jaw Opening	Cable Dia. 52mm (max.)
Safety Standard	CAT III 600V

CE



72-AUTO

CE



72T-AUTO



2520THz-AUTO

400A AC

Auto Ranging, 3¾ Digit, 4,000 Counts, Data Hold, Rel Test, NCV, APO

Ranges

AC Current	40A, 400A (Auto Ranging)
Accuracy	± (2.5%rdg + 5dgt)
Overload	400A AC max. for 1 min.
AC Voltage	4V, 40V, 400V, 600V (Auto Ranging)
Accuracy	± (1.2%rdg + 3dgt)
DC Voltage	400mV, 4V, 40V, 400V, 600V (Auto Ranging)
Accuracy	± (0.8%rdg + 3dgt)
Frequency	10Hz, 100Hz, 1000Hz, 10KHz, 100KHz, 1000KHz, 10MHz (Auto Ranging)
Accuracy	± (0.5%rdg + 2dgt)
Resistance	400Ω, 4kΩ, 40kΩ, 400kΩ, 4MΩ, 40MΩ (Auto Ranging)
Accuracy	± (1.2%rdg + 3dgt)
Audible Continuity	40Ω Approx
Diode Test Function	1.0 ± 0.6mA Approx
Power Battery Life	Two 1.5V 'AAA' Battery
Low Battery	200 Hours Typical " " is indicated
Dimension	185 x 65 x 28 mm (approx.)
Weight	170gms Including Battery (approx.)
Accessories	One Pair of Test Leads, Instruction Manual, Carrying Case, Battery (installed)
Jaw Opening	Cable Dia. 25mm (max.)
Safety Standard	CAT II 600V

400A AC

Auto Ranging, 3¾ Digit, 4,000 Counts, Temperature, Capacitance, Data Hold, Rel Test, NCV, APO

Ranges

AC Current	40A, 400A (Auto Ranging)
Accuracy	± (2.5%rdg + 5dgt)
Overload	400A AC max. for 1 min.
AC Voltage	4V, 40V, 400V, 600V (Auto Ranging)
Accuracy	± (1.2%rdg + 3dgt)
DC Voltage	400mV, 4V, 40V, 400V, 600V (Auto Ranging)
Accuracy	± (0.8%rdg + 3dgt)
Temperature	-20°C to 750°C
Accuracy	± (3%rdg + 5dgt)
Capacitance	5nF, 50nF, 500nF, 5μF, 50μF, 200μF
Accuracy	± (3%rdg + 2dgt)
Frequency	10Hz, 100Hz, 1000Hz, 10KHz, 100KHz, 1000KHz, 10MHz (Auto Ranging)
Accuracy	± (0.5%rdg + 2dgt)
Resistance	400Ω, 4kΩ, 40kΩ, 400kΩ, 4MΩ, 40MΩ (Auto Ranging)
Accuracy	± (1.2%rdg + 3dgt)
Audible Continuity	40Ω Approx
Diode Test Function	1.0 ± 0.6mA Approx
Power Battery Life	Two 1.5V 'AAA' Battery
Low Battery	200 Hours Typical " " is indicated
Dimension	185 x 65 x 28 mm (approx.)
Weight	170gms Including Battery (approx.)
Accessories	One Pair of Test Leads, Instruction Manual, Carrying Case, Battery (installed) K Type Thermocouple (upto 260°C)
Jaw Opening	Cable Dia. 25mm (max.)
Safety Standard	CAT II 600V

1000A AC

Auto / Manual, 3¾ Digit, 4,000 Counts, Temperature, Capacitance, Data Hold, Hz/Duty, NCV, APO

Ranges

AC Current	40A, 400A, 1000A
Accuracy	± (2.5%rdg + 5dgt)
Overload	1000A AC max. for 1 min.
AC Voltage	4V, 40V, 400V, 750V
Accuracy	± (1.2%rdg + 3dgt)
DC Voltage	400mV, 4V, 40V, 400V, 1000V
Accuracy	± (0.8%rdg + 3dgt)
Temperature	-20°C to 750°C
Accuracy	± (3%rdg + 5dgt)
Capacitance	5nF, 50nF, 500nF, 5μF, 50μF, 200μF (Auto Ranging)
Accuracy	± (3%rdg + 7dgt) > 5μF ± (5%rdg + 5dgt) > 100μF not Applicable
Frequency	10Hz, 100Hz, 1000Hz, 10KHz, 100KHz, 1000KHz, 10MHz (Auto Ranging)
Accuracy	± (0.5%rdg + 2dgt)
Duty cycle	0.1% - 99.9%
Accuracy	Reference only
Resistance	400Ω, 4kΩ, 40kΩ, 400kΩ, 4MΩ, 40MΩ
Accuracy	± (1.2%rdg + 3dgt)
Audible Continuity	30Ω Approx
Diode Test Function	1.0 ± 0.6mA Approx
Power Battery Life	Two 1.5V 'AA' Battery
Low Battery	200 Hours Typical " " is indicated
Dimension	245 x 95 x 35 mm (approx.)
Weight	309gms Including Battery (approx.)
Accessories	One Pair of Test Leads, Instruction Manual, Carrying Case, Battery (installed) K Type Thermocouple (upto 260°C)
Jaw Opening	Cable Dia. 52mm (max.)
Safety Standard	CAT III 600V

CE



3150



2250-Hz AUTO



Accessories

1000A AC	
Auto Ranging, 3$\frac{3}{4}$ Digit, 4,000 Counts, Data Hold, Frequency, Duty Cycle, Capacitance, APO Ranges	
AC Current	40A, 400A, 1000A
Accuracy	\pm (3%rdg + 4dgt) on 40A \pm (2%rdg + 4dgt) on 400A, 1000A
Overload	1000A AC max. for 1 min.
AC Voltage	4V, 40V, 400V, 750V (Auto) (40-500Hz)
Accuracy	\pm (1.0%rdg + 8dgt) on all ranges except \pm (1.5%rdg + 8dgt) on 750V
DC Voltage	4V, 40V, 400V, 1000V (Auto)
Accuracy	\pm (0.5%rdg + 4dgt) on 4V \pm (0.7%rdg + 4dgt) on 40V & 400V \pm (1%rdg + 4dgt) on 1000V
Resistance	400 Ω , 4k Ω , 40k Ω , 400k Ω , 4M Ω , 40M Ω , (Auto Ranging)
Accuracy	\pm (0.7%rdg + 4dgt) on all ranges except \pm (1.2%rdg + 4dgt) on 4M Ω \pm (2.5%rdg + 4dgt) on 40M Ω
Frequency Ranges	10.00Hz, 50.00Hz, 500.0Hz, 5.000KHz, 50.00KHz, 500.0KHz (Auto)
Accuracy	\pm (0.5%rdg + 2dgt)
Capacitance	40nF, 400nF, 4 μ F, 40 μ F, 100 μ F (auto-ranging)
Accuracy	\pm (5%rdg + 10dgt)
Audible Cont.	40 Ω Approx
Diode Test	1.0 \pm 0.6mA Approx
Power	Two 1.5V 'AAA' Battery
Battery Life	200 Hours Typical
Low Battery	" E " is indicated
Dimension	247 x 90 x 40 mm (approx.)
Weight	380gms Including Battery (approx.)
Accessories	One Pair of Test Leads, Instruction Manual, Carrying Case, 1.5V Battery (installed)
Jaw Opening	Cable Dia. 43mm (max.) Bus Bar 16mm x 65mm

1000A AC	
Auto Ranging, 3$\frac{3}{4}$ Digit, 4,000 Counts, Data Hold, Frequency, Duty Cycle, APO Ranges	
AC Current	40A, 400A, 1000A
Accuracy	\pm (3%rdg + 4dgt) on 40A \pm (2%rdg + 4dgt) on 400A, 1000A
Overload	1000A AC max. for 1 min.
AC Voltage	4V, 40V, 400V, 750V (Auto) (40-500Hz)
Accuracy	\pm (1.0%rdg + 8dgt) on all ranges except \pm (1.5%rdg + 8dgt) on 750V
DC Voltage	4V, 40V, 400V, 1000V (Auto)
Accuracy	\pm (0.5%rdg + 4dgt) on 4V \pm (0.7%rdg + 4dgt) on 40V & 400V \pm (1%rdg + 4dgt) on 1000V
Resistance	400 Ω , 4k Ω , 40k Ω , 400k Ω , 4M Ω , 40M Ω , (Auto Ranging)
Accuracy	\pm (0.7%rdg + 4dgt) on all ranges except \pm (1.2%rdg + 4dgt) on 4M Ω \pm (2.5%rdg + 4dgt) on 40M Ω
Frequency Ranges	10.00Hz, 50.00Hz, 500.0Hz, 5.000KHz, 50.00KHz, 500.0KHz (Auto)
Accuracy	\pm (0.5%rdg + 2dgt)
Sensitivity	3V
Over Volt Protection	200V DC or AC peak
% Duty Cycle	1% to 90% (Auto)
Accuracy	\pm (0.5%rdg + 5dgt)
Audible Cont.	40 Ω Approx
Diode Test	1.0 \pm 0.6mA Approx
Power	Two 1.5V 'AAA' Battery
Battery Life	200 Hours Typical
Low Battery	" E " is indicated
Dimension	250 x 98 x 35 mm (approx.)
Weight	375gms Including Battery (approx.)
Accessories	One Pair of Test Leads, Instruction Manual, Carrying Case, Battery (installed)
Jaw Opening	Cable Dia. 55mm (max.)

K Type Bead Probe (upto 260°C)
Model : TPK-B



K Type Stick Probe (upto 500°C)
Model : TP-02



Pair of Test Leads suitable for DMM/DTT
Model : TL-DMM/DTT



Pair of Test Leads suitable for Insulation Tester
Model : TL-IT





2727

CE



1008-TRMS

CE



3636

600A AC (TRMS)
3 3/4 Digit, 4,000 Counts, Frequency, Data Hold, Temperature

Ranges	
AC Current ^{TRMS}	40A, 400A, 600A
Accuracy	± (1.5%rdg + 4dgt) on all ranges (50-60Hz) ± (3.5%rdg + 5dgt) on all ranges (40-500 Hz)
Overload	600A AC max. for 1 min.
AC Voltage ^{TRMS}	400V, 750V (50-500 Hz)
Accuracy	± (2.9%rdg + 4dgt) on all ranges
DC Voltage	1000V
Accuracy	± (1.5%rdg + 1dgt)
Resistance	400Ω, 400KΩ
Accuracy	± (1.5%rdg + 3dgt) on all ranges
Frequency	4KHz, 40KHz (autoranging)
Accuracy	± (0.5%rdg + 3dgt) (for non distorted waveforms only)
Temp.	-20°C to 750°C
Accuracy	± (2%rdg + 3dgt) on -20°C to 500°C, ± (3%rdg + 2dgt) on 500°C to 750°C
Sp. Function	Audible Continuity, Diode Test function
Power	One 9V Battery
Battery Life	200 hours typical
Low Battery	"" is indicated
Dimension	192 x 82 x 33 mm (approx.)
Weight	270gms Including Battery (approx.)
Accessories	Supplied with a Pair of Test Leads, Carrying Case, K Type Thermocouple (upto 260°C) Battery & Instruction Manual
Jaw Opening	Cable Dia. 30mm (max.)

TRMS, Auto / Manual, 3 5/6 Digit, 6,000 Count LCD with Backlight, APO, Capacitance, Frequency, Duty Cycle & Temperature Ranges

Ranges	
DC Voltage	600mV/6/60/600/1000V
Accuracy	± (0.5%rdg + 3dgt)
AC Voltage ^{TRMS}	600mV/6/60/600/750V
Accuracy	± (0.8% rdg + 5dgt)
AC Response	40Hz ~ 1000Hz
DC Current	600/6000μA
Accuracy	± (0.8% rdg + 10dgt)
AC Current ^{TRMS}	600/6000μA / 600 / 1000A
Accuracy	± (2.0% rdg + 30dgt)
AC Response	40 Hz ~ 1000Hz
Overload	1000A AC Max. for 1min. for A
Resistance	600Ω/6/60/600kΩ/6/60MΩ
Accuracy	± (0.8% rdg + 5dgt) on 600Ω ± (0.8% rdg + 3dgt) on 6/60/600kΩ/6MΩ ± (1.0% rdg + 25dgt) on 60MΩ
Capacitance	9.999/99.99/999.9nF/9.999/99.99/999.9μF/9.999mF
Accuracy	± (3.5% rdg + 60dgt) on all ranges except ± (5.0% rdg + 10dgt) on 999.9μF & 9.999mF
Frequency	99.99Hz ~ 20.00MHz
Accuracy	± (0.01% rdg + 3dgt)
Duty Cycle	0.1% ~ 99.9%
Accuracy	± (0.01% rdg + 3dgt)
Temperature	-20°C ~ 1000°C / 0°F ~ 1832°F
Accuracy	± (1% rdg + 5dgt) on -20°C ~ 400°C ± (1.5% rdg + 15dgt) on 400°C ~ 1000°C ± (0.75% rdg + 5 dgt) on 0°F ~ 750°F ± (1.5% rdg + 15 dgt) on 750°F ~ 1832°F

1000A AC (TRMS)
3 1/2 Digit, 2,000 Counts, Data Hold, Max, Peak Audible Continuity, Diode Test function & Peak Hold

Ranges	
AC Current	20A, 200A, 1000A
Accuracy	± (1.5%rdg + 10dgt) upto 700A (50-60Hz) ± (2.0%rdg + 10dgt) on 700A - 1000A (50-60Hz)
AC Voltage	200V, 600V
Accuracy	± (1.2%rdg + 10dgt)
DC Voltage	600V
Accuracy	± (0.5%rdg + 1dgt)
Resistance	2kΩ, 200kΩ
Frequency	2kHz, 20kHz (auto-ranging)
Power	One 9V Battery
Protection	600V DC or AC rms overload protection in DCV, ACV, Diode, Ohm, Hz, Continuity
Dimensions	250 x 100 x 46 mm (approx.)
Weight	380gms Including Battery (approx.)
Accessories	Supplied with a Pair of Test Leads, Carrying Case, Battery (installed) & Inst. Manual
Jaw Opening	Cable Dia. 55mm (max.)

μA Measurement for HVAC	600.0μA / 6000μA
Flame Sensors	
Accuracy	± (1% rdg + 20 dgt)
Sp. Function	Diode Test, Audible Continuity, Data Hold
Power	Two 1.5V 'AA' Battery
Low Battery	'' is indicated
Battery Life	200 hours typical
Dimensions	238 x 90 x 48mm (approx.)
Weight	351gms Including Battery (app.)
Jaw Opening	30mm
Measuring Category	CAT IV 600V
Accessories	Supplied with Pair of Test Leads, Battery, K Type Thermocouple (upto 260°C), Instruction Manual & Carrying Case





36-AUTO



3690Auto



Accessories

600A DC / AC	
Auto Ranging, 3 3/4 Digit, 4,000 Counts, Temperature, Capacitance, Data Hold, Hz/Duty, NCV, APO	
Ranges	
AC Current	40A, 400A/600A
Accuracy	±(2.5%rdg + 8dgt) on 40A ±(2.5%rdg + 5dgt) on 400A/600A
Overload	600A AC max. for 1 min.
DC Current	40A, 400A/600A
Accuracy	±(3%rdg + 3dgt)
Overload	600A DC max. for 1 min.
AC Voltage	4V, 40V, 400V, 600V (Auto Ranging)
Accuracy	±(1.2%rdg + 3dgt)
DC Voltage	400mV, 4V, 40V, 400V, 600V (Auto Ranging)
Accuracy	±(0.8%rdg + 3dgt)
Temperature	-20°C to 750°C
Accuracy	±(3%rdg + 5dgt)
Capacitance	40nF, 400nF, 4µF, 40µF, 200µF (Auto Ranging)
Accuracy	±(3%rdg + 2dgt) ±(5%rdg + 8dgt) for 200µF
Frequency	10Hz, 100Hz, 1000Hz, 10KHz, 100KHz, 1000KHz, 10MHz (Auto Ranging)
Accuracy	±(0.5%rdg + 2dgt)
Duty Cycle	0.1% - 99.9%
Accuracy	Reference only
Resistance	400Ω, 4kΩ, 40kΩ, 400kΩ, 4MΩ, 40MΩ (Auto Ranging)
Accuracy	±(1%rdg + 3dgt)
Audible Continuity	30Ω Approx
Diode Test Function	1.0 ± 0.6mA Approx
Power	Two 1.5V 'AAA' Battery
Battery Life	200 Hours Typical
Low Battery	"  " "  " is indicated
Dimension	185 x 65 x 28 mm (approx.)
Weight	170gms Including Battery (approx.)
Accessories	One Pair of Test Leads, Instruction Manual, Carrying Case, Battery (installed)
Jaw Opening	K Type Thermocouple (upto 260°C)
Safety Standard	Cable Dia. 25mm (max.) CAT II 600V

Auto/Manual, 3 3/4 Digit, 4,000 Counts, 600A DC/AC, Frequency, Data Hold, Audible Continuity, Diode Test, Δ Zero Button (for DCA), APO	
Ranges	
AC Current	400A, 600A
Accuracy	±(1.75%rdg + 5dgt) (50 ~ 60Hz)
Overload	600A AC max. for 1 min.
AC Voltage	4V, 40V, 400V, 600V
Accuracy	±(1.2%rdg + 4dgt) ±(4%rdg + 5dgt) for 600V
DC Current	400A, 600A
Accuracy	±(1.5%rdg + 5dgt) for 400A ±(2%rdg + 5dgt) for 600A
Overload	600A DC max. for 1 min.
DC Voltage	400mV, 4V, 40V, 400V, 600V
Accuracy	±(0.5%rdg + 8dgt) ±(0.7%rdg + 2dgt) for 600V
Resistance	400Ω, 4kΩ, 40kΩ, 400kΩ, 4MΩ, 40MΩ
Accuracy	±(0.75%rdg + 8dgt) 400Ω to 400kΩ ±(1%rdg + 6dgt) 4MΩ ±(2%rdg + 4dgt) 40MΩ
Overload	600V DC / AC rms.
Frequency	100Hz, 1KHz, 10KHz, 100KHz, 500KHz
Accuracy	±(0.3%rdg + 2dgt)
Duty Cycle	1% to 90 %
Power	Two 1.5V 'AAA' Battery
Battery Life	150 hours (typical)
Low Battery	"  " is Indicated
Over Range	"OL" or "-OL" is indicated
Dimensions	220 x 85 x 46 mm (approx.)
Weight	280gms Including Battery (approx.)
Jaw Opening	Cable Dia. 30mm max.
Accessories	Supplied with a Pair of Test Leads, Battery (installed), Instr. Manual & Carrying Case

K Type Bead Probe (upto 260°C) Model : TPK-B	
K Type Stick Probe (upto 500°C) Model : TP-02	
Pair of Test Leads suitable for DMM/DTT Model : TL-DMM/DTT	
Pair of Test Leads suitable for Insulation Tester Model : TL-IT	



2003AUTO



1080-TRMS

2000A DC & 2000A AC (TRMS)
3 3/4 Digit, 6,000 Counts, 60 Segment Bargraph,
Auto - Ranging, Δ REL, Hz/Duty, MIN-MAX,
Data Hold, Audible Continuity, APO

Ranges

AC Current	600A, 2000A
Accuracy	±(3.5%rdg + 5dgt)
Overload	2000A AC max. for 1 min.
AC Voltage	6V, 60V, 600V (auto-ranging)
Accuracy	±(1%rdg + 6dgt) (50~60Hz) ±(2%rdg + 4dgt) (40~500Hz)
Overload	600V DC / AC rms.
DC Current	600A, 2000A
Accuracy	±(2.5%rdg + 5dgt)
Overload	2000A DC max. for 1 min.
DC Voltage	600mV, 6V, 60V, 600V (auto)
Accuracy	±(0.5%rdg + 5dgt)
Overload	600V DC / AC rms.
Resistance	600Ω, 6kΩ, 60kΩ, 600kΩ, 6MΩ, 60MΩ (auto-ranging)
Accuracy	±(0.3%rdg + 8dgt) 600Ω ±(0.3%rdg + 5dgt) 6-600kΩ ±(0.5%rdg + 5dgt) 6MΩ ±(2%rdg + 5dgt) 60MΩ
Overload	600V DC / AC rms.
Frequency	9.999Hz ~ 999.9KHz (auto-ranging)
Accuracy	±(0.1%rdg + 2dgt) (for non distorted waveforms only)
Overload	200V DC / AC rms.
% Duty Cycle	1% to 90% (Auto)
Accuracy	±(0.5%rdg + 5dgt)
Capacitance	40nF, 400nF, 4μF, 40μF (auto-ranging)
Accuracy	±(3%rdg + 40dgt) on 40nF (Use Δ REL) ±(3%rdg + 10dgt) on 400nF to 4μF ±(6%rdg + 10dgt) on 40μF
Overload	600V DC / AC rms.

TRMS, Auto / Manual, 3 5/6 Digit, 6,000
Count LCD with Backlight, APO,
Capacitance, Frequency, Duty Cycle &
Temperature Ranges

Ranges

DC Voltage	600mV/6/60/600/1000V
Accuracy	±(0.5%rdg + 3dgt)
AC Voltage	600mV/6/60/600/750V
Accuracy	±(0.8%rdg + 5dgt)
AC Response	40Hz ~ 1000Hz
DC Current	600/6000μA / 60 / 600 / 1200A
Accuracy	±(0.8%rdg + 10dgt) on 600 / 6000μA ±(2.0%rdg + 30dgt) on 60 / 600 / 1200A
Overload	1200A DC Max. for 1min. for A
AC Current	600/6000μA / 60 / 600 / 1200A
Accuracy	±(2.0%rdg + 30dgt) on all Ranges
AC Response	40 Hz ~ 1000Hz
Overload	1200A AC Max. for 1min. for A
Resistance	600Ω/6/60/600kΩ/6/60MΩ
Accuracy	±(0.8%rdg + 5dgt) on 600Ω

Sp. function

Sp. function	Audible continuity, Diode Test function
Power	One 9V Battery
Battery Life	25 hours (typical)
Low Battery	"" is Indicated
Over Range	"OL" or "-OL" is indicated
Dimensions	250 x 100 x 46 mm (approx.)
Weight	410gms Including Battery (approx.)
Jaw Opening	Cable Dia 55mm max.
Accessories	Supplied with a Pair of Test Leads, Battery (installed), Inst. Manual & Carrying Case

Capacitance

Accuracy

Frequency

Accuracy

Duty Cycle

Accuracy

Temperature

Accuracy

μA
Measurement
for HVAC

Flame
Sensors

Accuracy

Sp. Function

Power

Low Battery

Battery Life

Dimensions

Weight

Jaw Opening

Measuring

Catagory

Accessories

±(0.8%rdg + 3dgt) on 6/60/600kΩ/6MΩ
±(1.0%rdg + 25dgt) on 60MΩ
9.999/99.99/999.9nF/9.999/ 99.99/999.9μF/9.999mF
±(3.5%rdg + 60dgt) on all ranges except
±(5.0%rdg + 10dgt) on 999.9μF & 9.999mF
99.99Hz ~ 20.00MHz
±(0.01%rdg + 3dgt)
0.1% ~ 99.9%
±(0.01%rdg + 3dgt)
-20°C ~ 1000°C / 0°F ~ 1832°F
±(1%rdg + 5dgt) on -20°C ~ 400°C ±(1.5%rdg + 15dgt) on 400°C ~ 1000°C ±(0.75%rdg + 5dgt) on 0°F ~ 750°F ±(1.5%rdg + 15dgt) on 750°F ~ 1832°F
600.0μA / 6000μA
±(1%rdg + 20dgt)
Diode Test, Audible Continuity, Data Hold
One 9V Battery
'' is indicated
200 hours typical
238 x 90 x 48mm (approx.)
320gms Including Battery (approx.)
30mm
CAT IV 600V
Supplied with Pair of Test Leads, Battery, K Type Thermocouple (upto 260°C), Inst. Manual & Carrying Case



3600



3600 SUPER

<p>1200A DC & 1000A AC (TRMS) 3 3/4 Digit, 4,000 Counts, 40 Segment Bargraph, Auto & Manual Ranging, PEAK HOLD, MAX/MIN, Δ ZERO, DATA HOLD functions, APO</p> <p>Ranges</p> <p>AC Current 400A, 1000A^{TRMS} Accuracy ±(2.5%rdg + 5dgt) (50-60Hz) ±(3.5%rdg + 5dgt) (40-500Hz)</p> <p>Overload 1000A AC max. for 1 min.</p> <p>AC Voltage 4V, 40V, 400V, 600V^{TRMS} (Auto & Manual Ranging) Accuracy ±(0.75%rdg + 4dgt) (50-60Hz) ±(2%rdg + 4dgt) (40-500Hz) Note : 400mV AC for Reference only</p> <p>DC Current 400A, 1200A Accuracy ±(1.5%rdg + 5dgt) (upto 700A) ±(2%rdg + 5dgt) (700 - 1200A)</p> <p>Overload 1200 A DC max. for 1 min.</p> <p>DC Volt 400mV, 4V, 40V, 400V, 600V (Auto & Manual Ranging) Accuracy ±(0.25%rdg + 4dgt)</p> <p>Resistance 400Ω, 4kΩ, 40kΩ, 400kΩ, 4MΩ, 40MΩ (Auto & Manual Ranging) Accuracy ±(0.3%rdg + 5dgt) on 400Ω ±(0.3%rdg + 4dgt) on 4kΩ - 400kΩ ±(0.5%rdg + 4dgt) on 4MΩ ±(2.0%rdg + 4dgt) on 40MΩ</p> <p>Capacitance 4nF, 40nF, 400nF, 4μF, 40μF, 400μF, 4mF, 40mF (Auto & Manual Ranging) Accuracy ±(3%rdg + 20dgt) on 4nF (Use Δ ZERO) ±(3%rdg + 4dgt) on 40nF to 4mF ±(6%rdg + 4dgt) above 4mF</p>	<p>1200A DC & 1000A AC (TRMS) 3 3/4 Digit, 6,000 Counts, 60 Segment Bargraph, Auto & Manual Ranging, Δ ZERO, Hz/Duty, RPM MIN-MAX, Data Hold, Audible Continuity, APO</p> <p>Ranges</p> <p>AC Current 600A, 1000A^{TRMS} Accuracy ±(3.5%rdg + 5dgt) Overload 1000A AC max. for 1 min.</p> <p>AC Voltage 6V, 60V, 600V (Auto & Manual Ranging) Accuracy ±(1%rdg + 6dgt) (50 ~ 60Hz) ±(2%rdg + 4dgt) (40 ~ 500Hz)</p> <p>Overload 600V DC / AC rms.</p> <p>DC Current 600A, 1200A Accuracy ±(2.5%rdg + 5dgt) Overload 1200A DC max. for 1 min.</p>	<p>DC Voltage 600mV, 6V, 60V, 600V (Auto & Manual Ranging) Accuracy ±(0.5%rdg + 5dgt) Overload 600V DC / AC rms.</p> <p>Resistance 600Ω, 6kΩ, 60kΩ, 600kΩ, 6MΩ, 60MΩ, (Auto & Manual Ranging) Accuracy ±(0.3%rdg + 8dgt) 600Ω ±(0.3%rdg + 5dgt) 6 ~ 600kΩ ±(0.5%rdg + 5dgt) 6MΩ ±(2%rdg + 5dgt) 60MΩ</p> <p>Overload 600V DC / AC rms.</p> <p>Frequency 9.999Hz ~ 999.9KHz (auto-ranging) Accuracy ±(0.1%rdg + 2dgt) (for non distorted waveforms only)</p> <p>% Duty Cycle 1% to 90% Accuracy ±(0.5%rdg + 5dgt)</p> <p>RPM 9.999K RPM, 99.99K RPM (Auto Ranging) Accuracy ±0.5%rdg of fullscale</p> <p>Capacitance 40nF, 400nF, 4μF, 40μF (auto-ranging) Accuracy ±(3%rdg + 40dgt) on 40nF (Use Δ ZERO) ±(3%rdg + 10dgt) on 400nF to 4μF ±(6%rdg + 10dgt) on 40μF</p> <p>Overload 600V DC / AC rms.</p> <p>Sp. function Audible continuity, Diode Test function</p> <p>Power One 9V Battery</p> <p>Battery Life 150 hours (typical)</p> <p>Low Battery " " is indicated</p> <p>Protection 600VDC or AC rms overload protection in DCV, ACV, Diode, Ohms, Hz, Continuity.</p> <p>Dimensions 250 x 100 x 46 mm (approx.)</p> <p>Weight 386 gms Including Battery (approx.)</p> <p>Jaw Opening Cable Dia 55mm max.</p> <p>Accessories Supplied with a Pair of Test Leads, Carrying Case, Battery (installed) & Inst. Manual</p>
------------------------------------------------------------------------------------------------------------------------------------------------------------------------------------------------------------------------------------------------------------------------------------------------------------------------------------------------------------------------------------------------------------------------------------------------------------------------------------------------------------------------------------------------------------------------------------------------------------------------------------------------------------------------------------------------------------------------------------------------------------------------------------------------------------------------------------------------------------------------------------------------------------------------------------------------------------------------------------------------------------------------------------------------------------------------------------------------------------------------------------------------------------------------------------------------------------------------------------------------------------------------------------------------------------------------------------	-------------------------------------------------------------------------------------------------------------------------------------------------------------------------------------------------------------------------------------------------------------------------------------------------------------------------------------------------------------------------------------------------------------------------------------------------------------------------------------------------------------------------------------------------------------------------------------------------------------------------------------	----------------------------------------------------------------------------------------------------------------------------------------------------------------------------------------------------------------------------------------------------------------------------------------------------------------------------------------------------------------------------------------------------------------------------------------------------------------------------------------------------------------------------------------------------------------------------------------------------------------------------------------------------------------------------------------------------------------------------------------------------------------------------------------------------------------------------------------------------------------------------------------------------------------------------------------------------------------------------------------------------------------------------------------------------------------------------------------------------------------------------------------------------------------------------------------------------------------------------------------------------------------------------------------------------------------------------------------------------------------------------------------------------------------------------------------------------------------------------------------------------

MECO®

SINCE 1962

Testing & Measuring Instruments • Others



Reliable, Long-Lasting and Affordable Instruments ...since 1962 !

www.mecoinst.com

An ISO 9001-2008 Certified Company

MECO INSTRUMENTS PRIVATE LTD.

NAVI MUMBAI

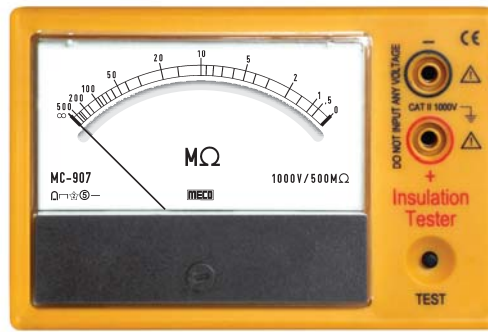

MC-900 Series/MC-900BA Series



Adaptor
(MC-900BA Series)

Features

- Single Person Push Button Operation
- High Accuracy $\pm 5\%$ of Indicated Value in Effective Range
- Scale Length : 80mm (approx.)
- Terminal Voltage : $> 85\%$ of Rated Voltage for Insulation Resistance
- Measurement from 10% to 100% of the Insulation Resistance Range
- ABS Resin Yellow Case with Polycarbonate Meter Front Cover
- Meets Requirement of IEC1010, Installation Category II, 1000V Phase Earth
- Designed to Generally Confirm to IS 10656-1983
- 7 Models with various Voltage & MOhm Ranges
- Battery Adaptor (Optional) for MC-900BA Series

Applications

Ideal for Insulation Resistance Measurement of

- Electrical Equipment (Motors, Transformers, Machines, etc.)
- Cables for Communication Networks
- Industrial, Commercial & Residential Installations
- Electrical Cables for Distribution Networks
- House Hold Appliances (Washing Machines, Mixer, Toaster, etc.)

Model	Range	Test Voltage DC
MC-901 / MC-901BA	0 - 20 M Ohms	100 V
MC-903 / MC-903BA	0 - 100 M Ohms	500 V
MC-904 / MC-904BA	0 - 500 M Ohms	500 V
MC-941 / MC-941BA	0 - 1000 M Ohms	500 V
MC-906 / MC-906BA	0 - 200 M Ohms	1000 V
MC-907 / MC-907BA	0 - 500 M Ohms	1000 V
MC-981 / MC-981BA	0 - 2000 M Ohms	1000 V

Specifications

Accuracy	$\pm 5\%$ of Indicated Value at $27^\circ\text{C} \pm 5^\circ\text{C}$
Operating Temperature	0° to 50°C
Storage Temperature	-10°C to 60°C
Relative Humidity	80% Maximum
Low Battery	When Battery Voltage Drops below Operating Voltage, Pointer cannot reach zero after shorting the Output Terminals.
Power	9V (6 x 1.5V AA) Battery
Dimensions	144.5 x 95 x 72.5 mm (approx.)
Weight	438.6 gms Including Battery (approx.)
Standard Accessories	Pair of Crocodile / Alligator Test Leads (Red & Black) x 1, Carrying Case x 1, 1.5V AA Batteries x 6 (Fitted - In), Battery Adaptor (Optional) for MC-900BA Series [Adaptor Input : 100 - 240V, 50 / 60Hz, 0.3A, Output : 9V \Rightarrow 500mA]
Dielectric Strength	3.5 KV @ 50Hz for 1 min. between Input Terminals & Case
Insulation Resistance	More than 50M Ohm at 500V between Circuit & Case

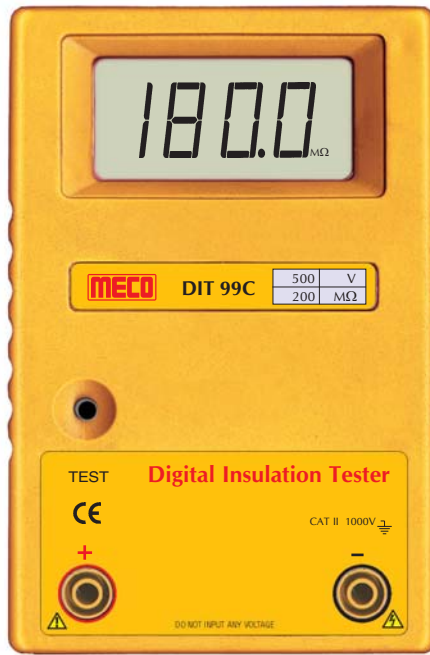

DIT 99 Series

Features

- 3½ Digit 17mm LCD Display
- High Accuracy \pm (3% rdg + 2 dgt)
- Single Person Push Button Operation
- Designed to Generally Conform to IS 10656-1983
- Meets Requirement of IEC1010, Installation Category II, 1000V Phase - Earth
- Terminal Voltage more than 85% of rated Voltage for Insulation Resistance Measurement from 10% to 100% of the Insulation Resistance Range
- 5 Models with various Voltage & MOhm Ranges
- Carrying Case

Applications

Ideal for Insulation Resistance Measurement of

- Electrical Equipment (Motors, Transformers, Machines, etc.)
- Electrical Cables for Distribution Networks
- Cables for Communication Networks
- House Hold Appliances (Washing Machines, Mixer, Toaster, etc.)
- Industrial, Commercial & Residential Installations

Model	Range	Test Voltage DC	Resolution
DIT 99A	0 - 20 M Ohms	100 V	0.01 M Ohms
DIT 99B	0 - 200 M Ohms	250 V	0.1 M Ohms
DIT 99C	0 - 200 M Ohms	500 V	0.1 M Ohms
DIT 99D	0 - 200 M Ohms	1000 V	0.1 M Ohms
DIT 99E	0 - 2000 M Ohms	1000 V	1 M Ohms

Specifications

Display	3½ digit LCD display, 17mm height with a maximum reading of 1999
Accuracy	\pm (3% rdg + 2 dgt) at 27°C \pm 5°C
Conversion Rate	2.5 sec
Over-Range Indication	" 1 " is Displayed
Operating Temperature	0° to 50° C
Storage Temperature	-20° C to 60° C
Relative Humidity	80% Maximum
Low Battery	' \pm ' is Displayed when Battery Voltage drops below Operating Voltage
Power	9V (6 x 1.5V AA) Battery
Dimensions	145 x 95 x 59 mm (approx.)
Weight	370gms Including Battery (approx.)
Standard Accessories	1 x Pair of Crocodile / Alligator Test Leads (Red & Black) 1 x Carrying Case 6 x 1.5V AA Batteries (Fitted - In) 1 x Instruction Manual
Dielectric Strength	3.5 KV @ 50Hz for 1 min. between Input Terminals & Case
Insulation Resistance	More than 50MOhm at 500V between Circuit & Case



Product Kit



DIT954



Introduction

MECO - DIT 954 is a 5KV Digital Insulation Tester with 3½ Digit (1999 Counts) Large Display and Backlight. It measures Insulation Resistance upto 200GΩ, AC Voltage upto 600VAC and checks Phase Sequence and Phase Status Indication.

Features

- 3½ Digit (1999 Counts) Large LCD Display
- High Accuracy ±(3%rdg+5 digit) for Insulation Measurement
±(2%rdg+5 digit) for AC Voltage Measurement
- Range Selection & Single Person Push Button Operation
- LCD with Green Back Light Function with Indicator Switch
- Data Holding Function, Function Icons on Display
- Measurement of AC Voltage upto 600VAC
- Measurement of Phase Sequence Between (Phase - Phase Voltage) with LED Indicators & Beep Facility
- Auto Range (Insulation Test)
- Red LED Indicator for HV (High Voltage)
- Inbuilt Protection Circuit to prevent the harm of reverse Voltages.
- Battery Operated with AC Adaptor
- 3 Ranges of High Voltage & Insulation Resistance

Electrical Specifications

Accuracy : ±(% reading + digits) at 23°C±5°C; RH≤75%

Specification	Test voltage	Range	Accuracy	Resolution
Insulation Resistance	1000V / 2500V / 5000V	0.1MΩ to 200GΩ	±(3%rdg+5 dgt.)	0.01MΩ
AC Voltage Measurement	0 - 600VAC (50 - 60Hz)	-	±(2%rdg+5 dgt.)	1V
Phase Sequence Test	100V - 450V (Phase - Phase) 40 - 60Hz	-	-	-

General Specifications

Display	3½ Digit (1999 Counts) Large LCD Display with 29mm Digit Height
Accuracy	±(3%rdg+5 digit) for Insulation Resistance Range ±(2%rdg+5 digit) for AC Voltage Measurement
Over-Range Indication	'1' is displayed
Operating Temperature	0°C to 40°C (RH ≤ 80%)
Storage Temperature	- 10°C to 50°C (RH ≤ 75%)
Power	12V (8X1.5V) (R6AA size batteries) or AC Adaptor 12VDC
Dimensions	190 x 155 x 75mm (approx.)
Weight	900 gms including batteries (approx.)
Standard Accessories	Insulation Resistance Measurement Test Leads for High Voltage x 1 Set Phase Sequence Measurement Wires x 1 set AC Adaptor x 1, 1.5V AA Batteries x 8 Heavy Duty Carry Case x 1 Instruction Manual x 1

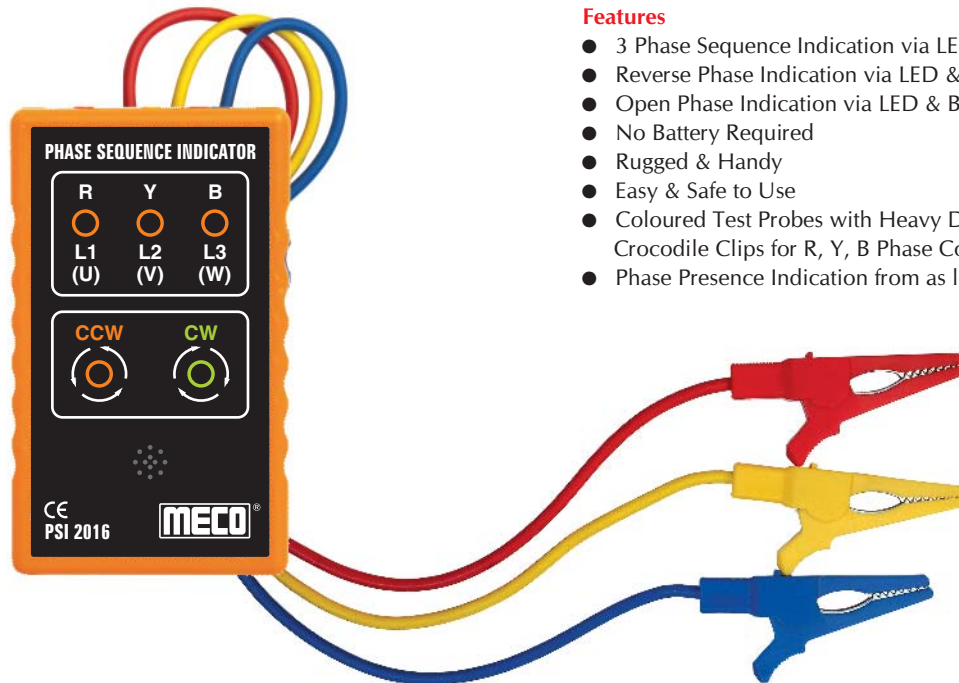

Features

- 3 Phase Sequence Indication via LED & Buzzer
- Reverse Phase Indication via LED & Buzzer
- Open Phase Indication via LED & Buzzer
- No Battery Required
- Rugged & Handy
- Easy & Safe to Use
- Coloured Test Probes with Heavy Duty Insulated Crocodile Clips for R, Y, B Phase Connections
- Phase Presence Indication from as low as 60V AC (PH-N)

PSI 2016

Introduction

In Electrical Systems, sometimes without identification of Phase Sequence it is impossible to proceed further. The Phase Sequence Indicator is used to determine the Phase Sequence R, Y & B of 3 Phase Voltages. It is important that Phase Sequence is known properly prior to energizing electrical motors and other equipment, as incorrect connection could cause damage to the equipment. The correct operation of measuring instruments like 3 Phase Energy Meter, 3 Phase Power Meter & Automatic Control of devices also depends on the Phase Sequence.

PHASE SEQUENCE INDICATOR	PHASE SEQUENCE INDICATOR	PHASE SEQUENCE INDICATOR
<p>Correct Phase (CW)</p> <ul style="list-style-type: none"> ● All 3 Yellow LED's ON ● Green LED ON ● Intermittent Beep 	<p>Reverse Phase (CCW)</p> <ul style="list-style-type: none"> ● All 3 Yellow LED's ON ● Red LED ON ● Continuous Beep 	<p>Open Phase (One Phase Only)</p> <ul style="list-style-type: none"> ● Yellow LED for Open Phase is OFF e.g. R Phase LED OFF ● Both Green & Red LED's OFF ● Continuous Beep

Electrical Specifications	
Voltage Range	60 - 600V AC
Frequency Range	40 - 400Hz
Operating time for continuous Measurement	60 minutes Max. at 200VAC, 4 minutes Max. at 500VAC
Withstand Voltage	4000 V for one minute
Environmental Specifications	
Storage Temperature	- 20°C ~ 60°C
Operating Temperature	- 10°C ~ 40°C
Safety Specifications	
Electrical Safety	EN 61010 - 1
Over Voltage category	CAT III 600 V, CAT IV 300V
Mechanical & General Specifications	
Size	100 x 60 x 24.5mm (approx.)
Weight	185g (approx.)
Case & Housing Material	ABS
Accessories	
	Test Leads with Insulated Crocodile Clips & Carrying Case.



4671

Features

- 10µA Ultra High Resolution
- Large Conductor Diameter (30mm)
- AC Current in 5 Ranges (40mA, 400mA, 4A, 40A, 60A)
- Wide Frequency Response (40Hz ~ 1KHz)
- AC A, AC V, Ω and Continuity
- Large 3¾ Digit LCD (4000 Count)
- 40 Segment Fast Bargraph Display (30 times/sec.)
- Data Hold and Max/Min Hold
- Relative Measurement
- 600 Vrms Overload Protection in Resistance Range

General Specifications

Jaw Opening	Cable Dia 30mm. max. (approx.)
Battery Type	Two 1.5V SUM-3
Display	3¾ LCD with 40 Segment Bargraph
Range Selection	Manual
Overload Indication	OL
Power Consumption	15mA (approx.)
Low Battery Indication	B
Sampling Time	3 time/sec. (display) 30 time/sec. (bargraph)
Operating Environment	-10° to 50°C, RH < 85%
Storage Environment	-20°C to 60°C, RH < 75%
Altitude	up to 2000M
Dimensions	210 x 72 x 36 mm
Weight	210gms Including Battery (approx.)
Accessories	Carrying Case x 1, Users Manual x 1, Battery (installed), Test Leads x 1 pair

Specifications (23°C ± 5°C)

AC Current		Accuracy	
Range	Resolution	50/60 Hz	Wide (40Hz ~ 1KHz)
40 mA	10 µA	± 1.0%rdg ± 3dpts	± 2.0%rdg ± 5dpts
400 mA	100 µA		
4 A	1 mA		
40 A	10 mA		
60 A (0 ~ 50A)	100 mA	± 1.5%rdg ± 3dpts	± 3.0%rdg ± 5dpts
60 A (50 ~ 60A)	100 mA	± 3.0%rdg ± 5dpts	± 3.5%rdg ± 5dpts

Though the Meter can Display upto 400A, the Calibration is valid upto 60A

Resistance (Ω) and Continuity (Open Voltage 0.4V)				
Range	Resolution	Accuracy	Beeping	OL Protection
40 ~ 400Ω	0.1Ω	± 1.0%rdg ± 2dpts	< 38.0 Ω	AC 600V

AC Voltage (Input Impedance : 10 MΩ)				
Range	Resolution	Accuracy		Overload Protection
		50/60 Hz	40 ~ 1KHz	
400V	0.1V	± 1.5%rdg ± 2dpts	± 2.0%rdg ± 4dpts	AC 800V

Fault Tracing of Live Installation

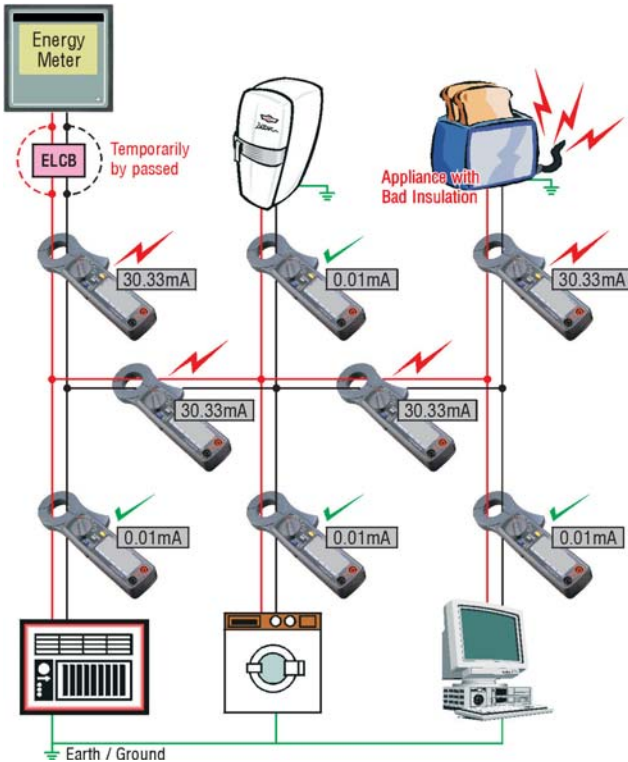

Application





DET 2016

Precision Earth Resistance Measurement

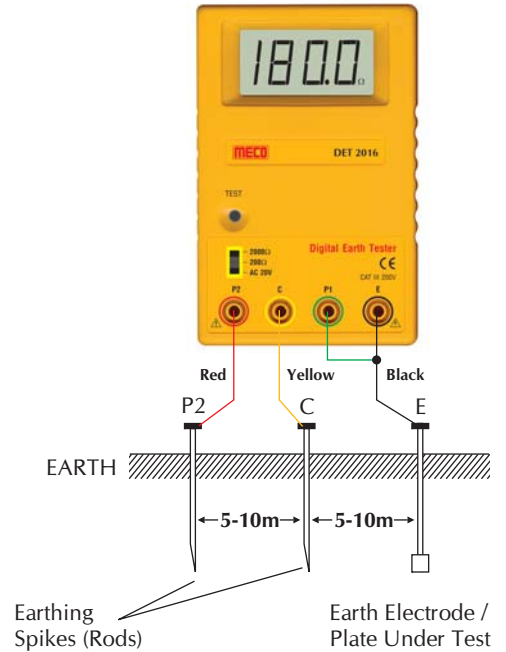

Introduction

MECO DET 2016 is designed with technical know how from FUSO Electric Company of Japan. It is useful for measurement of Earth Resistance of Earthing used in the Electrical Equipment. This Instrument finds wide applications for testing Earthing of installations in Power Industries, Telecommunication Networks & Electrical Traction Systems etc. It also measures Earth Voltage.

Features

- 3½ Digit (1999 Counts) LCD Display
- Auto Power Off Function (after 5min.)
- Low Battery Warning Indication
- Capable of Measuring Earth Voltage (0 - 20V AC)
- Small, Light Weight & Portable
- Extremely Simple to Operate Connect - Press - Read
- Designed to Reject High Levels of Noise & Interference
- Designed to Generally Conform to IS10656-1983
- Range Selection & Single Person Push Button Operation Switches
- Two Ranges for Earth Resistance Measurement
- Functions Icons on Display
- Battery Operated
- IEC 1010 CAT III 200V
- Sturdy, Elegant & Compact Body

Electrical Specifications

Specification	Range	Resolution
Earth Resistance	0 - 200Ω	0.1Ω
	0 - 2000Ω	1Ω
Earth Voltage	0 - 20VAC	0.01VAC

General Specifications :

Display	3½ dgt. (1999 Counts) LCD Display with 17mm height.	
Accuracy	± 3% rdg. + 5 dgt. For Earth Resistance	at 23°C ± 5°C
	± 1% rdg. + 2 dgt. For Earth Voltage	
Conversion Rate	2.5 Sec	
Over Range Indication	"1" is displayed	
Operating Temperature	0° to 50°C	
Storage Temperature	-20° to 60°C	
Relative Humidity	80% Maximum	
Low Battery	'' Is Displayed when Battery Voltage drops below Operating Voltage	
Power	9V (6 x 1.5V 'AA') Batteries	
Dimensions	145 x 95 x 59mm (approx.)	
Weight	390gms. Including Battery (approx.)	
Accessories (Standard)	Carrying Case x 1, 1.5V 'AA' Batteries (fitted in) x 6, Instruction Manual x 1, Carton x 1	
Accessories (Optional)	Test Leads x 1 Set (Red, Yellow, Black), Earthing Spikes (Rods) x 3, Hammer x 1, Carrying Case	
Dielectric Strength	2.5KV @ 50Hz for 1min, between Input Terminals & Case	
Insulation Resistance	More than 50MΩ @ 500V between Circuit & Case	



The faults in any Electrical System are unavoidable. Earthing plays an important role in Generation, Transmission & Distribution for safe and proper operation of any Electrical Installation. **MECO 4680BL/4680BLC Clamp-On Earth / Ground Resistance Tester** has long jaw suitable for Earthing Strip of 65mm x 32mm. It completely eliminates the use of ground and auxiliary rods thus saving lot of time and avoiding shutdown. Calibration check can be verified by using the Resistance Verification Plate provided. This is an extremely handy instrument especially at place where it is next to impossible to measure Earth / Ground Resistance by conventional methods. Substantial time saving and easy operating justify the investment in these instruments.

Features

- Non Contact Ground Resistance Measurement
- No Auxillary Electrodes Needed
- Data Storing Memory
- Data Hold, Noise Signal
- Ground Resistance Measurement 0.01Ω ~ 1000Ω
- Suitable for Earthing Strip of 65mm x 32mm
- Leakage Current (0.5mA ~ 30.00A) (Model 4680BLC)
- Auto Ranging
- Continuity Loop Test
- Auto Power Off

General Specifications

- Jaw : 65 x 32 mm Approx.
 Conductor Size : Φ65 mm * 32 mm
 Battery Type : 1.5V (AA) x 4 (Alkaline)
 Display : 4 Digit 9999 counts LCD
 Range Selection : Auto
 Memory : 99 Sets
 Overload Indication : OL
 Low Battery Indication : B
 Operating Environment : -10°C ~ 55°C
 Dimensions : 293 x 90 x 66 mm
 Weight : 1250 gms Including Battery (approx)
 Accessories : Resistance Verification Plate x 1,
 Battery 1.5V (AA) x 4 (Installed),
 User Manual x 1, Carry Bag x 1
 Configurable Alarm : Resistance : 1 ~ 199Ω
 Current : 1 ~ 499mA

Electrical Specifications (23°C ± 5°C)

Ground Resistance (Auto Range) (4680BL, 4680BLC)		
Range	Resolution	Accuracy of Reading
0.010 ~ 0.099 Ω	0.001 Ω	± (1% + 0.01 Ω)
0.10 ~ 0.99 Ω	0.01 Ω	± (1% + 0.01 Ω)
1.0 ~ 49.9 Ω	0.1 Ω	± (1.5% + 0.1 Ω)
50.0 ~ 99.5 Ω	0.5 Ω	± (2% + 0.5 Ω)
100 ~ 199 Ω	1 Ω	± (3% + 1 Ω)
200 ~ 395 Ω	5 Ω	± (6% + 5 Ω)
400 ~ 590 Ω	10 Ω	± (10% + 10 Ω)
600 ~ 1000 Ω	20 Ω	± (20% + 20 Ω)

Ground & Leakage Current: Auto Ranging, 45/65Hz, RMS (4680BLC)		
Range	Resolution	Accuracy of Reading
0 ~ 80 mA	0.05 mA	± (2.5% + 1 mA)
80 mA ~ 650 mA	0.5 mA	± (2.5% + 2 mA)
650 mA ~ 4 A	5 mA	± (2.5% + 10 mA)
4 A ~ 30 A	10 mA	± (2.5% + 20 mA)



Carry Bag



Resistance Verification Plate

4680BL, 4680BLC

Applications

Hazards due to improper earth / ground happen around us everyday. Systems are becoming more and more complex and faults in any system are unavoidable. Every electrical equipment, appliance or network must be properly earthed to allow a low resistance path for dissipation of leakage current into the earth. MECO Clamp-On Earth / Ground Resistance Tester can measure accurately within a few minutes the ground resistance & AC current (load & leakage) of all types of installations by just clamping to the grounding lines without disconnecting the circuit or driving auxiliary electrodes. A few of the applications have been illustrated below :

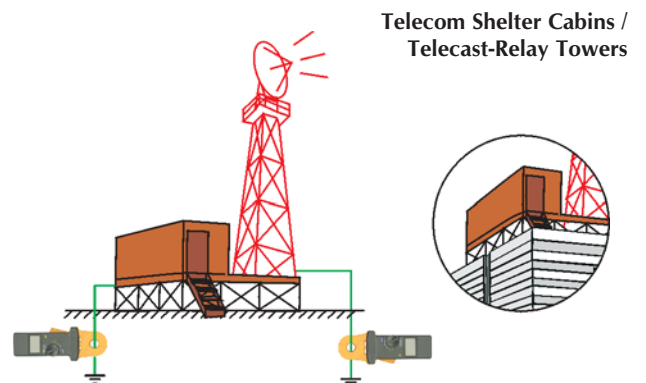
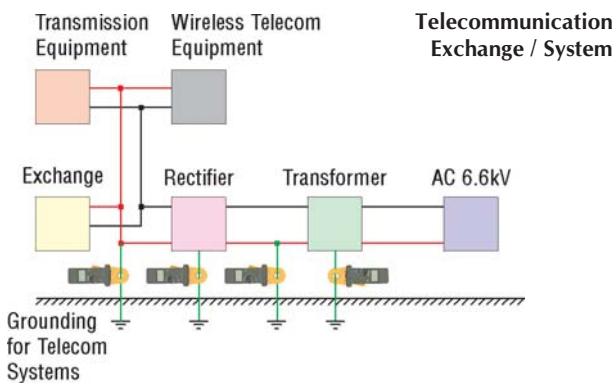
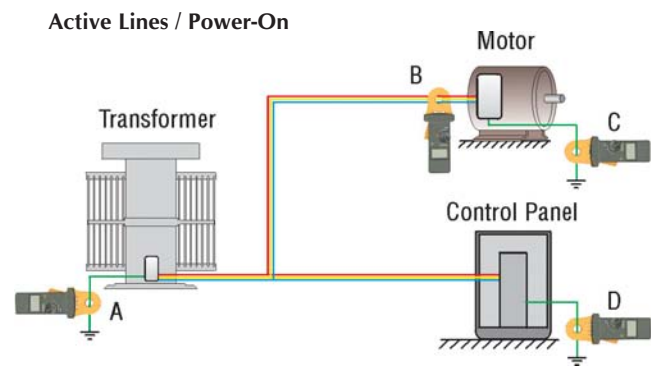
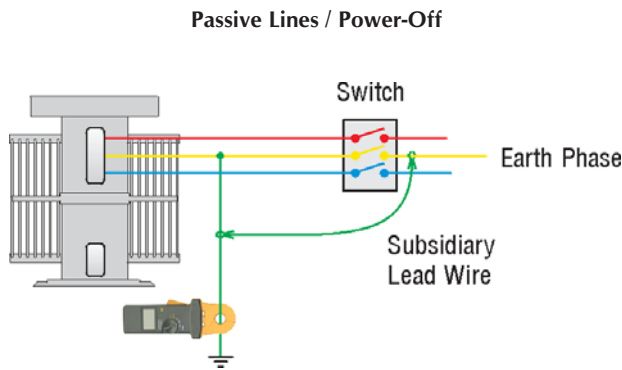
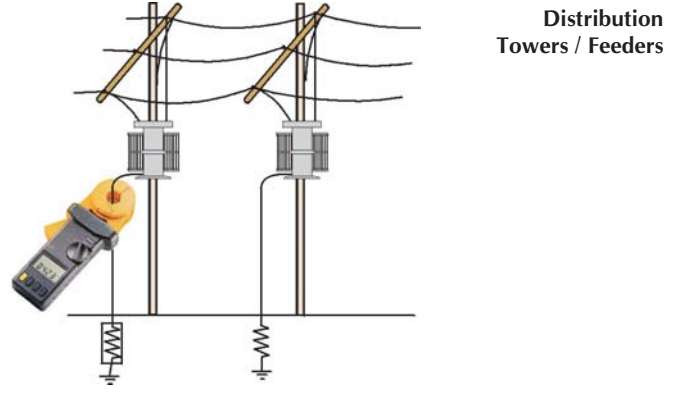
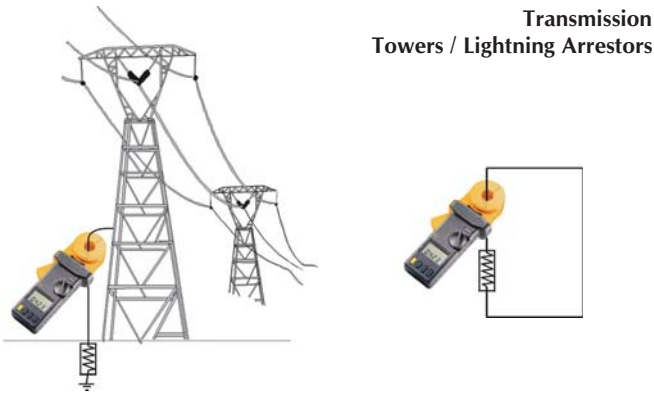

Hazardous Storage Tanks for Petrol / Oil / Gas / Chemicals

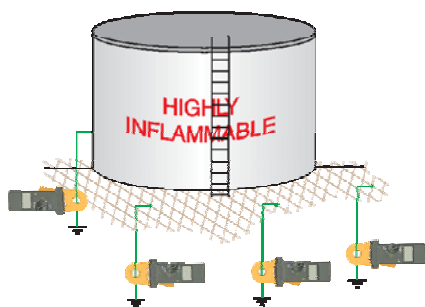

Household Electrical Appliances

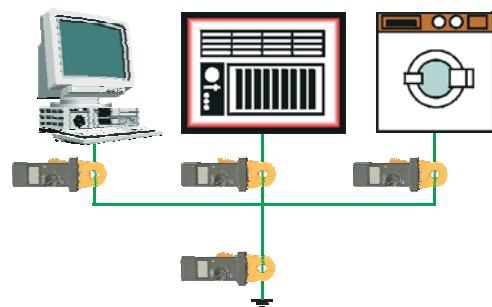

CE



Features

- Non Contact Ground Resistance Measurement
- No Auxiliary Electrodes Needed
- Recording / 116 Sets of Memory
- Ground Resistance Measurement 0.025Ω ~ 1500Ω
- Suitable for Ground Wire upto Φ 23mm (Model 4680)
- Suitable for Ground Wire upto Φ 34.5mm (Model 4680B)
- Leakage Current (0.300mA ~ 30.00A) (Model 4680)
- Leakage Current (0.300mA ~ 35.00A) (Model 4680B)
- Programmable High & Low Alarm
- Programmable Data Logging
- Auto Range
- Continuity Loop Test
- Auto Power Off

General Specifications

- Jaw Opening : 23 mm approx. (Model 4680)
38 mm approx. (Model 4680B)
- Battery Type : 9V (Alkaline)
- Display : 4 Digit 9999 Counts LCD
- Range Selection : Auto
- Overload Indication : OL
- Power Consumption : 40mA (approx.)
- Low Battery Indication : **B**
- Operating Environment : 0° ~ 50°C, RH < 85%
- Storage Environment : -20°C ~ 60°C, RH < 75%
- Dimensions : 257 x 100 x 47 mm (Model 4680)
276 x 102 x 51 mm (Model 4680B)
- Weight : 670 gms Including Battery (approx.) (4680)/
790 gms Including Battery (approx.) (4680B)
- Accessories : Resistance Verification Plate x 1,
Battery (installed) x 1, User Manual x 1,
Carry Box x 1, Cleaning Brush x 1

Electrical Specifications (23°C ± 5°C)

Ground Resistance (Auto Range)		
Range	Resolution	Accuracy of Reading ^{1,2}
0.025 ~ 0.250 Ω	0.002 Ω	± 1.5%rdg ± 0.05Ω
0.251 ~ 1.000 Ω	0.02 Ω	± 1.5%rdg ± 0.05Ω
1.001 ~ 10.00 Ω	0.02 Ω	± 1.5%rdg ± 0.1Ω
10.01 ~ 50.00 Ω	0.04 Ω	± 2.0%rdg ± 0.3Ω
50.01 ~ 100.0 Ω	0.04 Ω	± 2.0%rdg ± 0.5Ω
100.1 ~ 200.0 Ω	0.4 Ω	± 3.0%rdg ± 1.0Ω
200.1 ~ 400.0 Ω	2 Ω	± 5.0%rdg ± 5Ω
400.1 ~ 600.0 Ω	5 Ω	± 10%rdg ± 10Ω
600.1 ~ 1500 Ω	20 Ω	± 20%rdg

1. Loop resistance noninductive, external field < 50A/m (4680) or < 200A/m (4680B), external electrical field < 1V/m, conductor centered.
2. Resistance Measurement Frequency : 3.333KHz

Ground & Leakage Current: Auto Ranging, 50/60Hz, TRMS, Crest Factor < 3.0 for (4680) or < 3.5 for (4680B)		
Range	Resolution	Accuracy of Reading
0.300 ~ 1.000 mA	0.001 mA	± 2.0%rdg ± 0.05mA
1.00 ~ 10.00 mA	0.01 mA	± 2.0%rdg ± 0.03mA
10.0 ~ 100.0 mA	0.1 mA	± 2.0%rdg ± 0.3mA
100 ~ 1000 mA	1 mA	± 2.0%rdg ± 3mA
0.200 ~ 4.000A	0.001A	± 2.0%rdg ± 0.03A
4.00 ~ 30.00A (4680)	0.01A	± 3.0%rdg ± 0.03A
4.00 ~ 35.00A (4680B)	0.01A	± 3.0%rdg ± 0.03A

Accuracy of Resistance Calibration Plate : ± 1%
Data Logging Capacity : 116 Records
Data Logging Interval : 1 ~ 255 Seconds



4680, 4680B



LCR999A

Features

- Basic measurement accuracy 0.1% & speed upto 10 meas / sec.
- Large LCD display with bright white backlight.
- Ultra low power consumption, battery powered for 24 hours of continuous use.
- Automatic identification function (Ai).
- Percentage display & 4 tolerance comparator : 1%,5%,10% & 20%
- 9V battery & External power supply
- Automatic correction function with datahold, max. / min. / average recording.
- Utility function configuration & current setup recovery after power off.
- Standard Mini-USB interface, SCPI compatible
- Auto power Off
- Constant output impedance : 100 ohm

Application

- Field maintenance test & external carrying test.
- Fixation point on production line or mobile checkout.
- Warehouse & real time spot or batch inspection.
- Flow inspect and in field measurements.

Specifications

Function	
Measurement Parameter	Primary Parameters : L / C / R / Z Secondary Parameter : D / Q / θ / ESR
Equivalent Mode	Series, Parallel
Auto LCR Function	Manual / Auto
Ranging Mode	Auto
Test Terminals	2-Terminal, 4-Terminal, 5-Terminal
Measurement Speed	10 meas/sec (fast), 5 meas/sec (med), 2 meas/sec (slow)
Correction	Short , Open
Tolerance Mode	1%, 5%, 10%, 20%
Input Protection Fuse	0.1A / 63V
Interface	Mini-USB (Virtual Serial Port)
Test Signal	
Signal Frequency	100Hz, 120Hz, 1KHz, 10KHz
Test Signal Level	0.6 Vrms
Output Impedance	100 Ω
Basic Accuracy	0.1%
Measuring Range	L 4 μ H ~ 1000H Range for Display 0.001 μ H ~ 1000.0H
	C 4pF ~ 20mF Range for Display 0.001pF ~ 20.000mF
	R / Z 0.4 Ω ~ 10M Ω Range for Display 0.0001 Ω ~ 10.000M Ω
	ESR Range for Display 0.0000 Ω ~ 999.9 Ω , Resolution : 0.0001 Ω
	D Range for Display 0.0000 ~ 9.999, Resolution : 0.0001
	Q Range for Display 0.0000 ~ 9999, Resolution : 0.0001
θ Range for Display - 179.9 $^{\circ}$ ~ 179.9 $^{\circ}$, Resolution : 0.01 $^{\circ}$	
Environment	0 $^{\circ}$ C ~ 40 $^{\circ}$ C, \leq 90% RH
Power Supply	
Battery Model	7.2V Ni-MH 600mAH Rechargeable Battery
AC Adaptor	Input : 220V (1 \pm 10%), 50Hz (1 \pm 5%) : Output 12V DC
Charge Time & Current	Continuous Charge Time : Max. 80min. Charge Current : Max. 150mA
Battery Capacity Indication	Real Time Display on LCD
General	
Dimensions	193 x 93 x 48mm
Weight	395gms (approx.)
Safety and EMC compliance	IEC 61010-1 : 2001, IEC 61326-2-1 : 2005
Accessories	Manual, Short Circuit Plate x 1, 7.2V Ni MH Rechargeable Battery (installed) x 1, 12V/300mA AC Adapter x 1, 5 Terminal Kelvin Test Leads x 1 Optional : SMD 4 Terminal Kelvin Test Tweezers x 1, Banana Plugs-Crocodile Clip Test Leads x 1, Mini USB Communication Cable & S/W CD



7002, 7272

Application

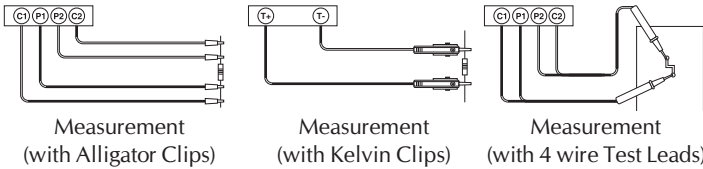

Electrical Specifications (23°C ± 5°C)

Manual Range

	Resistance Range	Resolution	Accuracy
10A (7272)	400μΩ ~ 4000μΩ	1μΩ	±0.25% ± 25μΩ
	1.500mΩ ~ 16.000mΩ	1μΩ	±0.25% ± 25μΩ
	5.000mΩ ~ 60.000mΩ	1μΩ	±0.25% ± 25μΩ
5A (7002)	1.000mΩ ~ 8.000mΩ	1μΩ	±0.25% ± 25μΩ
	5.00mΩ ~ 32.00mΩ	10μΩ	±0.25% ± 250μΩ
	10.00mΩ ~ 120.00mΩ	10μΩ	±0.25% ± 250μΩ
1A	4.00mΩ ~ 40.00mΩ	10μΩ	±0.25% ± 250μΩ
	15.00mΩ ~ 160.00mΩ	10μΩ	±0.25% ± 250μΩ
	50.00mΩ ~ 600.00mΩ	10μΩ	±0.25% ± 250μΩ
100mA	0.0400Ω ~ 0.4000Ω	100μΩ	±0.25% ± 2.5mΩ
	0.1500Ω ~ 1.6000Ω	100μΩ	±0.25% ± 2.5mΩ
	0.5000Ω ~ 6.0000Ω	100μΩ	±0.25% ± 2.5mΩ
10mA	0.400Ω ~ 4.000Ω	1mΩ	±0.25% ± 25mΩ
	1.500Ω ~ 16.000Ω	1mΩ	±0.25% ± 25mΩ
	5.000Ω ~ 60.000Ω	1mΩ	±0.25% ± 25mΩ
1mA	4.00Ω ~ 40.00Ω	10mΩ	±0.25% ± 250mΩ
	15.00Ω ~ 160.00Ω	10mΩ	±0.25% ± 250mΩ
	50.00Ω ~ 600.00Ω	10mΩ	±0.25% ± 250mΩ
100μA	0.0400kΩ ~ 0.4000kΩ	100mΩ	±0.75% ± 3Ω
	0.1500kΩ ~ 1.6000kΩ	100mΩ	±0.75% ± 3Ω
	0.5000kΩ ~ 6.0000kΩ	100mΩ	±0.75% ± 3Ω

Features

- Basic Accuracy 0.25%
- Max. Test Current : 10A (60mΩ) for 7272, 5A (120mΩ) for 7002
- Manual or Auto Range
- Four Terminal Kelvin Measurement
- 6 Ranges with 1μΩ Best Resolution
- Measurement of Resistive and Inductive Materials
- Setting for HI, LO & PASS Readings
- Memory of 3000 Measurements Data
- Programmable HI-LO Alarm with memory of 20 Data
- Large LCD with Backlight & HOLD Function
- Low Power Consumption
- Battery Operated (Rechargeable Battery)
- Low Battery indication
- LED indication for Invalid Resistance Measurement
- Cable Length Measurement in feet & meters
- User Interface Software for PC Communication via RS232C (to USB Bridge) Cable
- Built-in Battery Charging Circuit & Calendar Clock

General Specifications

- Battery Charging Time 10Hrs
- AC Adaptor : Input 110V or 220V AC, Output DC 15V/1 ~ 3A
- LCD Display 4 5/6 Digit + Backlight
- Dimension : 260 x 158 x 70mm (approx.)
- Weight : 1125gms Including Battery (approx.)
- Environment : 0°C ~ 50°C ≤ 85% RH (Operation)
: -20°C ~ 60°C ≤ 75% RH (Storage)

Accessories

- Users Manual x 1 ● Software Manual x 1 ● Software CD x 1
- RS232C (to USB Bridge) Cable x 1 ● AC Adaptor x 1
- 11.1V Rechargeable Lithium Battery (2500mAh) x 1 for 7002
- 11.1V Rechargeable Lithium Battery (3800mAh) x 1 for 7272
- 1 Set of Kelvin Clips
- Carrying Bag ● Optional : 4 Wire Test Leads

Electrical Specifications (23°C ± 5°C)

Auto Range

	Resistance Range	Resolution	Accuracy
10A (7272)	400μΩ ~ 60.000mΩ	1μΩ	±0.25% ± 25μΩ
5A (7002)	1.000mΩ ~ 8.000mΩ	1μΩ	±0.25% ± 25μΩ
	8.00mΩ ~ 120.00mΩ	10μΩ	±0.25% ± 250μΩ
1A	4.00mΩ ~ 600.00mΩ	10μΩ	±0.25% ± 250μΩ
100mA	0.0400Ω ~ 6.0000Ω	100μΩ	±0.25% ± 2.5mΩ
10mA	0.400Ω ~ 60.000Ω	1mΩ	±0.25% ± 25mΩ
1mA	4.00Ω ~ 600.00Ω	10mΩ	±0.25% ± 250mΩ
100μA	0.0400kΩ ~ 6.0000kΩ	100mΩ	±0.75% ± 3Ω

Software

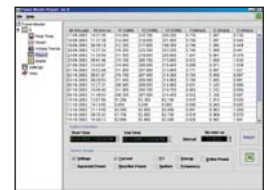

Application program to represent Real Time Values & Facility to open / save recorded data, plot data, export data, print display screen, parameter setting etc. The screen also displays current time, start time, system mode, sample rate, high limit, low limit, sample count & present sample value. The program also supports plotting of present or recorded data.



TTR 8100

Transformer is a very important Element in the Electric Power Distribution System. It needs to be maintained from time to time to Guarantee Smooth Power Supply at Consumer end.

MECO TTR8100 is Portable instrument for accurate measurement of 1-Phase & 3-Phase Transformer/VT/CT Turns Ratio, Excitation Voltage, Current, Phase Angle and Deviation. TTR8100 ensure the Correct Turn Ratio & Quality of the Transformer.

It Checks live Test Points, Short Circuit, Open Circuit and Reverse Polarity before each measurement.

Features

- Measurements of 1Φ and 3Φ Transformer/VT/CT Turns Ratio
- VT/PT Ratio 0.8~10000, CT Ratio 0.8~2000
- Graphical and Literal Illustration of Measurements and connections with Large Back-lighted Dot Matrix 240x128 LCD
- Displays Turns Ratio, Deviation, Secondary Output, Excitation Voltage and Current, Phase Angle and Nameplate. Transformer /VT/CT Values in one page for easy quality interpretation.
- Check for Live Test Points, Short Circuit, Open Circuit and Reverse Polarity before each measurement.
- Store 4096 Files of Transformer Nameplate Values (VT/PT/CT /1Φ/3Φ, Test Frequency, Primary and Secondary Voltages or Ratio, RCF) and Measuring Data.
- Ten test Frequencies (50~400Hz)
- 9 Types of 3Φ Winding Connections pre-installed.
- Wireless Blue Tooth Communication with PC.
- Select Filter to Remove Field noise (Slow, Normal, Fast)
- Record with Date and Time Stamp
- Powerful lithium Battery (3400mAH) with built-in Charging Circuit
- User Programmable RCF (Reference Correction Factor, 0.99~1.01) to Correct Accuracy within 1% Error
- PC Application Software Included
- Friendly File System for Easy On-site Data Retrieval and Nameplate Values Management

Reference Conditions : 23°C ± 5°C (30 to 50% RH) Add 25ppm/°C for -10° to 18°C and 28° to 50°C to all Accuracy Specifications. No external electrical or magnetic fields. Output current < 150mA for VT/PT and < 50mA for CT. Calibration Cycle is 1 Year.

Electrical

Ratio Range (VT/PT)	Autoranging : 0.8000 to 10000:1	
Accuracy (70Hz)	Ratio Range	Accuracy (%of Reading)
	0.8000 to 999.99	±0.1%
	1000.0 to 4999.9	±0.2%
	5000.0 to 10000	±0.25%
Ratio Range (CT)	Autoranging : 0.8000 to 2000.0	
Accuracy (70Hz)	Ratio Range	Accuracy (%of Reading)
	0.8000 to 2000.0	±0.5%
Excitation Signal	VT/PT Mode : 34Vrms max CT Mode : Auto Level 0 to 1A, 0.1 to 20Vrms	
Excitation Current Display	Range : 0 to 1000mA Accuracy : ±(2% of Reading + 2mA)	
Excitation Frequency (Hz)	50, 55, 60, 70, 100, 120, 200, 240, 300, 400	
Display	5" Large Dot Matrix LCD Display (240x128) with Backlight	
Power Source	Rechargeable Lithium Battery, 3400mAh	
Battery Life	Over 10Hrs of Continuous Operation. Battery life (%) Indication	
Battery Charger	Universal Input (90 to 264Vrms Input)	
Charging Time	< 4Hrs	
Data Storage	4096 Files Each (VTM, CTM, VTR, CTR, BMP)	
Date/Time	Battery-Backed, Real-time Calendar Clock	
Measurement Method	ANSI/IEEE C57.12.90 and IEC 600076.1	
Accessory	Test Leads x 1 Pair, Alligator Clips x 4, Rechargeable Lithium Battery x 1, Instruction Manual x 1, AC Adaptor x 1, Power Cord x 1, Software CD and Manual x 1, Carrying Bag x 1	

Application



Accessories





CREDA
CHHATTISGARH STATE RENEWABLE ENERGY DEVELOPMENT AGENCY
(Dept. of Energy, Govt. of Chhattisgarh)
2nd Floor, CSERC Building, Shanti Nagar, RAIPUR (C.G.)
Tel.: +91-771-4019230, 4019231, 4019227, 4019228; Fax: 0771-4268389
E-mail: info@creda.in Website: www.creda.in

CREDA/EC/F-8D/SI/44624
Raipur, Date: 30 DEC 2015

TO WHOMSOEVER IT MAY CONCERN

It gives us immense pleasure & satisfaction to put on record our appreciation for M/s. Mecro Meters Pvt. Ltd., Navi Mumbai from whom we had purchased "Battery Capacity Tester" model No.-6363.

The performance of the instrument found to be satisfactory & excellent during the field inspection & testing of lead acid battery of the solar photovoltaic plant.

We also express our appreciation to the team of M/s. Mecro Meters Pvt. Ltd. for their excellent service support to CREDA.

I find the "Battery Capacity Tester" is very effective as well as essential electrical measuring instrument for testing & inspection of battery in solar photovoltaic plant.

Date: 30.12.2015
Place: Raipur

(Sanjeev Jain)
Chief Engineer, CREDA



CREDA - Energetic agency with ever lasting energy sources



1st Floor Energy Building
Pandit Deendayal Petroleum University Campus
Gandhinagar, Gujarat - 382 007, INDIA
Phone : +91-79-2327 5361
Fax : +91-79-2327 5380
Email : information@germi.org
Website : www.germi.org

ENERGY EDUCATION
RESEARCH & DEVELOPMENT
ENERGY AWARENESS & PUBLICATION
ENERGY CONSULTANCY

GUJARAT ENERGY RESEARCH
AND MANAGEMENT INSTITUTE

Dr. Omkar Jani
Principal Research Scientist, Solar Energy Research Wing
GERMI Research, Innovation and Incubation Centre

GERMI/Solar/2016/554
4 January 2016

TO WHOMSOEVER IT MAY CONCERN

This is to certify that "SOLIR SYSTEM INILYZER MODEL: 9018 BT" , which is procured vide our Purchase Order number GERMI/SRWTRG/2015/021 dated 24.11.2015 from **M/s. Mecro Meters Private Limited**, Mahape, Navi Mumbai for Gujarat Energy Research and Management Institute, Gandhinagar, Gujarat, is for our internal use, training and research purpose.

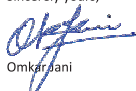
Sincerely yours,

Omkar Jani

भारत सरकार
अन्तरिक्ष विभाग
इसरो उपग्रह केन्द्र
पोस्ट बॉक्स नं. 1795, हवाई पटन मार्ग
विमानतट डाक घा, बेंगलूरु - 560 017, भारत
दूरभाष :
फैक्स :



Government of India
Department of Space
25 JUL 2013
ISRO Satellite Centre
Post Box. No. 1795, Airport Road, Vimanapura Post
Bangalore - 560 017, India
Telephone :
Fax :
25084024
25205283/84

ISCP-2012-0-24809-0101 LO 17/07/2013

WHOM SO EVER IT MAY CONCERN

This is to certify that "SOLAR MODULE ANALYSER" (SMA) **LOW POWER SMA AND HIGH POWER SMA** which is procured vide our Purchase Order No. ISCP-2012-0-24809-0101 LO Dated.17.06.2013 from **M/s. MECO METERS PVT LTD., MAHAPE** for ISRO Satellite Centre, Bangalore, is for our own use. There will not be any commercial transactions involved or re-sale of these items.

These materials are being transported through carriers.

It is requested not to detain enroute, as the item is required very urgently at the destination.

V.SARAVANAN
Purchase & Stores Officer



भारतीय अन्तरिक्ष अनुसंधान संगठन
Indian Space Research Organisation



T +91 - 40 - 4946 4332 (IDEA)
F +91 - 40 - 4946 4333
Toll Free 1-800-102-4332 (IDEA)
info@solaridea.com
www.solaridea.com

4th January, 2016

To,
M/s. MECO Meters Pvt. Ltd.
Plot No. EL - 60, MIDC, Electronic Zone,
TTC Industrial Area, Mahape,
Navi Mumbai - 400710 (India)
Tel. No. 022 - 27673300
Fax No. 022 - 27673310

Kind Attention: Mr. Kamal Goliya / Mr. Prashant Thakkar
Subject: Performance of MECO Solar System Analyzer - 9018BT

Dear Sir,

We are pleased to inform you that performance of MECO Solar System Analyzer 9018BT supplied to us is working well and is meeting our expectations.

We are using the MECO Solar System Analyzer for analyzing and improving the efficiency of our Solar Inverters, Solar pumps, and other solar systems. We are also able to assess the PV panel performance and furthermore, we are able to adjust the panels spacing and tilt angle to obtain optimum power from the PV panels.

The analyzer is found to be reliable and we have pleasure in recommending the same to others.

We look forward to having similar kind of service and support from you in the future.

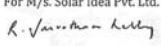
With Best Regards
For M/s. Solar Idea Pvt. Ltd.

Managing Director



SOLAR IDEA PRIVATE LIMITED, CIN : U40106TG2014PTC094915
Registered Office : Door No. 8-2-277/A/7, Plot No. 126, Road No. 2, Banjara Hills, Hyderabad -500034, Telangana State, India.

MECO®

SINCE 1962

- Automotive Meters
- Battery Capacity Testers



Reliable, Long-Lasting and Affordable Instruments ...since 1962 !

www.mecoinst.com

An ISO 9001-2008 Certified Company

MECO INSTRUMENTS PRIVATE LTD.

NAVI MUMBAI



ABM18



BM63

Introduction

A battery is an electrochemical cell that is charged externally to store electrical power. The stored power of the battery is released when it is needed for various applications that could be required for normal day to day working, back-up operations, critical applications or for emergencies. The use of batteries is increasing every day in order to drive / support various applications such as Cars, Motor Cycles, UPS, Generators, Automobiles, Emergency Lights, Solar Power etc.

A battery is expected to always perform flawlessly as per its capacity. However sometimes even new batteries fail and hence periodic testing and maintenance of batteries is required. It is important to also test incoming batteries as a part of the quality control procedure to ensure proper compliance of the supply made by the battery manufacturer. The loss of battery capacity occurs gradually often without the knowledge of the user.

The function of the Battery Meters MECO ABM18 and BM63 is to check the capacity condition of various lead acid storage batteries and to ensure that the supported equipment is adequately backed-up, prevented from unexpected failures and forewarned for any calamity. The battery tester helps to identify the weak batteries so that they can be re-charged or weeded out of the system before they make the complete system unreliable.

ABM18

MECO ABM18 is a portable Automobile Battery Meter which can check the capacity condition of different types of Motorcycle and Motorcar batteries from 2 to 200Ah.

The product consists of a DC Voltmeter, Load Resistor and Testing Clip. The state of the battery is indicated on the meter dial as 'FULLUP' (White), 'NORMAL' (Green), 'RECHARGE' (Yellow), 'DISCHARGE' (Red) directly.

Technical Specifications

Rated Voltage of Battery to be Tested : 2, 6, 12V DC
Rated Capacity of Battery to be Tested : 2 - 200Ah
Dimensions : 225 x 124 x 68mm (approx.)
Weight : 500gms (approx.)

Application

MOTORCYCLE	CAPACITY	VOLTAGE	MOTORCAR	CAPACITY	VOLTAGE
50cc	2Ah	6V or 12V	20 - 360cc	20 - 24Ah	6V or 12V
51 - 125cc	6 - 10Ah		500 - 2000cc	30 - 60Ah	
126 - 250cc	9 - 15Ah		2000 - 5000cc	55 - 100Ah	
251 - 750cc	10 - 18Ah		5000 - 8000cc	100 - 200Ah	

BM63

MECO BM63 is a portable Battery Meter which can check the capacity condition of different types of batteries from 4 to 500Ah.

The product consists of a DC Voltmeter, Load Resistor and Testing Clip. The state of the battery is indicated on the meter dial as 'OK' (Green), 'WEAK' (Yellow) and 'BAD' (Red) directly.

Technical Specifications

Rated Voltage of Battery to be Tested : 2, 6, 12V DC
Rated Capacity of Battery to be Tested : 4 - 500Ah
Dimensions : 220 x 120 x 70mm (approx.)
Weight : 550gms (approx.)





LCD Screen

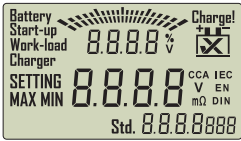

VBSM6129
VBSM6246

Features

- Key Parameters Measured and Displayed for Battery Diagnosis
- Display of Battery Condition [Good / Ok / Pay Attention / Replace]
- Overload Protection to ensure Operator Safety
- Loose Lead Detection, Reverse Polarity Protection, Unit Conversion CCA / IEC / EN / DIN

Specifications	Range
CCA Range	100 ~ 1700
IEC Range	100 ~ 1000
EN Range	100 ~ 1700
DIN Range	100 ~ 1000
Displays Battery Internal Resistance	✓
Displays Battery Voltage	Display Volts
Displays Battery Condition	Good / OK / Pay Attention / Replace
Test 12V Batteries	For Model VBSM6129
Test 12V/24V Batteries	For Model VBSM6246
Battery Recharge Indicator	✓
Reverse Polarity Protection	✓
Detects and Displays Bad Cell	✓
Loose Lead Detection	✓
Internal Unit Conversion EN, IEC, DIN	✓
Overload Protection of Input Voltage	✓
Cable Length	700mm (approx.)
Dimension	180 x 90 x 32mm (approx.)
Weight	400g (approx.)

Terminal Shutter Interlock

When Ohm Measurement Selected



When mA Measurement Selected



When 20A Measurement Selected



6255

Features

- Terminal Shutter Interlock Mechanism Prevents Wrong Operations
- 11 Functions
- Heavy Duty Rubber Holster
- Data Hold, Auto Power Off
- Measurement of Duty, Ignition Frequency, Ms-Pulse Width, RPM & DWELL

Specifications	Range	Accuracy
Ignition Frequency	0.1Hz ~ 20KHz	±(1.5% + 10)
Pulse Width	0.1 ~ 999.9ms	±(1.5% + 10)
RPM	2STR : 300 ~ 19999 rpm 4STR : 600 ~ 19999 rpm	±(3% + 5)
DC V	20V / 200V 1000V	±(0.5% + 3) ±(0.8% + 3)
AC V	20V / 200V 700V	±(1% + 5) ±(1.2% + 5)
DC A	20mA / 200mA 20A	±(1.5% + 5) ±(2% + 10)
AC A	20mA / 200mA 20A	±(2% + 5) ±(3% + 10)
Resistance	200Ω 2K / 20K / 200K / 2M	±(1% + 5) ±(1% + 1)
Frequency	2KHz / 20KHz	±(1.5% + 10)
Temperature	-40 ~ 0°C 0 ~ 400°C 400 ~ 1000°C	±(5% + 5) ±(1% + 3) ±(2% + 3)
DUTY	0.1% - 99.9%	NA
DWELL	1 / 2 / 3 / 4 / 5 / 6 / 8	±(3% + 5)
Continuity Buzzer	✓	NA
Diode Test	✓	NA
Transistor Test	✓	NA
Power Source	9V Battery	NA
Dimension	200 x 85 x 38 mm (approx.)	NA
Weight	800g (approx.)	NA



LCD Screen



MAM6120

User Changable
Pinpoint or Hook
Test Leads



MAM6138

User Changable
Pinpoint or Hook
Test Leads



Features

- 2 in 1 Automotive Auto Ranging DMM & Power Probe (MAM6120)
- 3 in 1 Automotive Auto Ranging DMM, Power Probe & Logic Probe (MAM6138)
- Pen Type Design Perfect for Automotive Diagnosis

- Hands - Free Test Leads for Excellent Convenience
- Flashlight for Operation of Automotive Diagnosis
- Auto Range, Auto Power Off, Low Battery Warning & Data Hold

Specification	Range [Accuracy]	MAM6120	MAM6138
VDC	200mV / 2V / 20V / 200V / 600V [± (0.5% + 5)]	●	●
VAC	2V / 20V / 200V / 600V [± (1.2% + 5)]	●	●
Resistance	200 / 2000 / 20K / 200K / 2M / 20MΩ [± (0.8% + 5)]	●	●
Continuity Buzzer	✓	●	●
Diode	✓	●	●
Logic Level and Pulse Test (TTL / CMOS)	6V / 12V / 24V	NA	●
Test Lighter (Bulb Style Circuit Tester)	12V / 24V	●	●
Flash Light	✓	●	●
Data Hold	✓	●	●
Auto Range	✓	●	●
Manual Range	✓	●	●
Auto Power Off	✓	●	●
Low Battery Warning	✓	●	●
Power Source	1.5V AAA × 2	●	●
Max. Display	1999	●	●
Dimension	210 × 60 × 32mm (approx.)	●	●
Weight	240g (approx.)	●	●

Standard Accessories

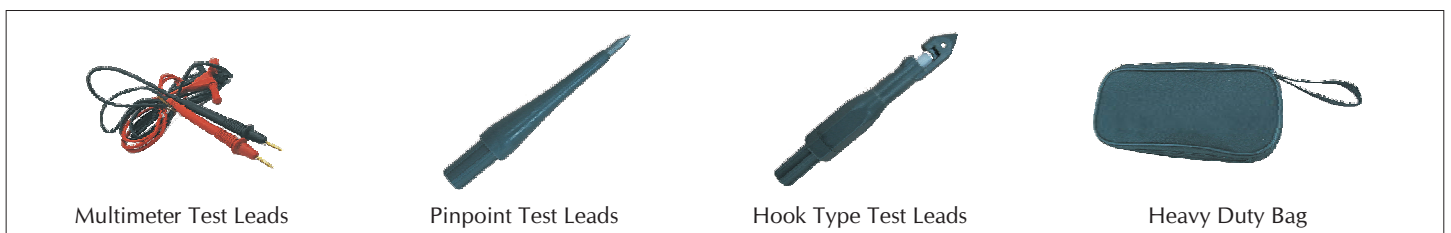

Multimeter Test Leads

Pinpoint Test Leads

Hook Type Test Leads

Heavy Duty Bag

What is Internal Resistance of Battery?

One of the basic requirements of a battery for digital applications is low internal resistance. Measured in milliohms, the internal resistance is the gatekeeper that, to a large extent, determines the runtime. The lower the resistance, the less restriction the battery encounters in delivering the needed power. The internal resistance (IR) of a battery is defined as the opposition to the flow of current within the battery. There are two basic components that impact the internal resistance of a battery; they are electronic resistance and ionic resistance. The electronic resistance plus the ionic resistance will be referred to as the total effective resistance.

How does Internal Resistance affect Performance?

Storage batteries are repeatedly charged and discharged over a long interval. This tends to gradually deteriorate the battery performance and the internal resistance increases until charging is no longer possible. Faults may also be caused by internal short-circuits, reducing the battery voltage, making the battery over-heat or in the case of a short-circuit caused by corrosion, possibly even leading to a fire.

A high mW reading can trigger an early 'low battery' indication on a seemingly good battery because the available energy cannot be delivered in the required demand and remains inside the battery.

The internal resistance of a battery is dependent on the specific battery's size, chemical properties, age, temperature and the discharge current.

Low Resistance High Resistance

Effects of internal battery resistance
A battery with low internal resistance delivers current to the equipment (Load) as per requirement. High internal resistance causes battery voltage to drop. Because of drop in voltage, current flowing to the equipment (Load) gets cut-off leaving energy in the battery.

Typical internal resistance readings of a lead acid battery
The readings were taken at open circuit voltage (OCV).

MECO Battery Capacity Tester

In the modern age with the increase in various portable devices, maintenance of batteries has become crucial as the performance of these devices depend on life of batteries. Because of continues charging and discharging of batteries their performance gradually deteriorates until charging is no longer possible which may result in sudden failure of the system.

MECO Batter Capacity Testers can give quick results on the state of a battery either as PASS, WARNING or FAIL which is based on comparator settings of internal resistance and the voltage for various batteries. MECO Battery Capacity Testers can check all types of batteries including Nickel-Metal Hydride batteries (NiMH), Nickel Cadmium batteries (NiCd), Lithium-Ion batteries (Li-ion), Alkaline batteries and Lead-Acid batteries. Users can choose from 2 models to suit their applications : Battery Capacity Tester Model 6363 for testing batteries upto 40V and 500Ah, and Battery Capacity Tester Model 6390 for testing batteries upto 60V and 1200Ah.

The analysis of batteries state is PASS / WARNING / FAIL based on a six-way combination of comparisons against upper and lower limits of Internal Resistance and Voltage threshold. This result is then indicated by LEDs and a beeper.

Comparator Table

Resistance \ Voltage	Low Limit Resistance		High Limit Resistance	
	Lo	Middle	Middle	Hi
Voltage	WARNING Beeper	WARNING Beeper	WARNING Beeper	FAIL Beeper
Comparison Value	PASS	WARNING Beeper	WARNING Beeper	FAIL Beeper

Applications (For 6363 & 6390)

For Manufacturers, R & D Units, Service Centers, Technicians, Dealers & Service Executives in following industries

- Battery
- Solar Energy
- IT
- UPS
- Wind Energy
- Telecom
- Automobile
- Lift
- Aircraft
- Emergency Power Backup
- Crane & forklift
- Railways

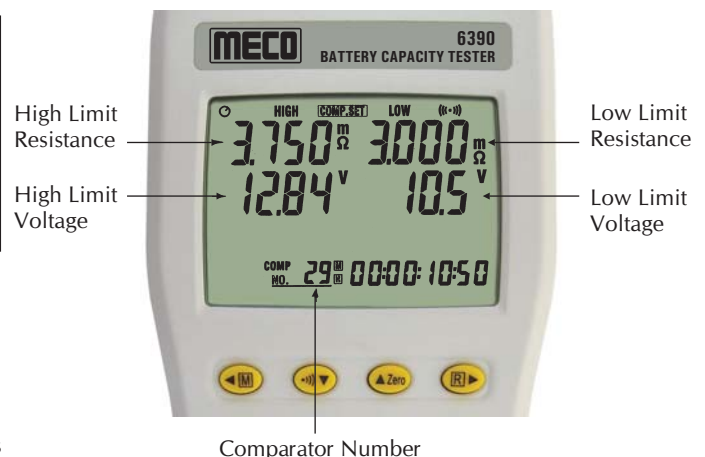



Product Kit



6363



Top Connections



Software Window



Features

- Memory & Read Function
- Right Device to know the TRUE-LIFE of Battery Capacity (Resistance / Voltage) Simultaneously Measure
- On-line Testing without shutting down battery
- Built-in Comparator Function
- Rates Conditions as PASS, WARNING or FAIL
- Datalogging Memory Function
- Compact and Lightweight
- RS-232 Interface & Software
- Auto Power Off

Specifications

Battery Types Tested	UPS Battery, Motor Cycle (6V/12V : 2 ~ 20Ah), Car (12V : 21 ~ 80Ah), Truck (12V : 83 ~ 160Ah) Household Appliances [(9V : upto 625 mAh), (AA : upto 2850 mAh), (AAA : upto 1250 mAh), (C : upto 8350 mAh), (D : upto 20500 mAh)], Lithium Notebook Battery [(14.8V : 3600 ~ 4800 mAh), (11.1V : 3600 ~ 7200 mAh)], Lithium Digital Camera Battery (3.7V : 650 ~ 1350 mAh), Lithium Cordless Phone Battery (3.7V : 800 ~ 1250 mAh),
Battery Capacity	0 to 500Ah
Resistance	Ranges : 40mΩ, 400mΩ, 4Ω, 40Ω Resolution : 10μΩ, 100μΩ, 1mΩ, 10mΩ Accuracy : ± (1% Reading + 10 Digits) on all Ranges
Measurement Condition	Current : 25mA, 2.5mA, 250μA, 25μA Frequency : 1KHz± 10%
Voltage	Measurement : 4V, 40V Resolution : 1mV, 10mV Accuracy : ± (0.1% Reading + 6 Digits)
Open Circuit Terminal Voltage	≤ 3.5V PP
Manual Data Logging	500 Sets
Continuous Data Logging	9600 Sets
Comparator Settings	Resistance High and Low Limits and Voltage Throughhold Point
Number of Comparator Settings	99 Sets
Operating Environment	0°C to 40°C (32°F to 104°F), 80% RH or Less, Non-Condensing
Maximum Input Voltage	50VDC
Power Supply	Six 1.5V AA Size Batteries
Battery Life	7 Hours
Dimensions / Weight	250 x 102 x 48 mm (approx.) / 490gms Including Batteries (approx.)
Accessories	Instruction Manual x 1, Batteries (installed), Test Probe (Alligator Clips) x 1, RS232 Cable x 1, Software Disk x 1, Carrying Bag x 1, Carrying Bag x 1, Optional : Thermal Printer x 1



DC Current Adaptor

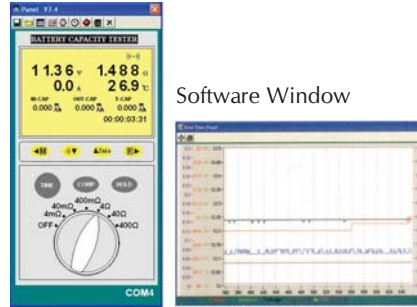

Software Window

Features

- Right Device to know the TRUE-LIFE of Battery Capacity (Resistance / Voltage / Current & Temperature) Simultaneously
- Measure battery charge / discharge capacity (Ah)
- Measure battery State of Charge SOC (%)
- On-line Testing without shutting down battery
- Built-in Comparator Function
- Rates Conditions as PASS, WARNING or FAIL
- Datalogging Memory Function
- Compact and lightweight
- Optical USB Interface & Software
- Load Test Analysis (Charge / Discharge)
- Auto-Hold & Auto-Data Storage
- Wide Range 0 ~ 1200 Ah
- Auto Power Off
- Memory & Read Function

Specifications

6390

Battery Types Tested	UPS Battery, Motor Cycle (6V/12V : 2 ~ 20Ah), Car (12V : 21 ~ 80Ah), Truck (12V : 83 ~ 160Ah) Household Appliances [(9V : upto 625 mAh), (AA : upto 2850 mAh), (AAA : upto 1250 mAh), (C : upto 8350 mAh), (D : upto 20500 mAh)], Lithium Notebook Battery : [(14.8V : 3600 ~ 4800 mAh), (11.1V : 3600 ~ 7200 mAh)], Lithium Digital Camera Battery : (3.7V : 650 ~ 1350 mAh), Lithium Cordless Phone Battery : (3.7V : 800 ~ 1250 mAh),
Battery Capacity	0 to 1200Ah
Resistance	Ranges : 4mΩ, 40mΩ, 400mΩ, 4Ω, 40Ω, 400Ω Resolution : 1μΩ, 10μΩ, 100μΩ, 1mΩ, 10mΩ, 100mΩ Accuracy : ± (0.8% reading + 6 digits) on all ranges. except ± (3% reading + 20 digits) on 4mΩ
Measurement Condition	Current : Approx. 40mA, 4mA, 400μA, 40μA, 4μA Frequency : 1KHz± 30Hz
DC Voltage	Range : 6V, 60V; Resolution : 1mV, 10mV; Accuracy : ±(0.1% reading + 6 digits)
Temperature	Range : -20°C to 60°C (-4°F to 140°F); Resolution : 0.1°C / 0.1°F; Accuracy : ± 1°C / ± 1.8°F
DC Current	Range : 4A; Resolution : 1mA; Accuracy : ± (2%rdg + 2dgt), Range : 30A; Resolution : 10mA; Accuracy : ± (2%rdg + 3dgt), Range : 600A; Resolution : 0.1A; Accuracy : ± (2%rdg + 2dgt)
Open Circuit Voltage	5V max
Datalogging	999 Data Sets of Manual & Auto Data Memory / 6000 Data Sets (only use PC Download)
Comparator	Setting : Resistance Upper and Lower Limits and Voltage Upper and Lower Limit Memory : 99 Sets of Values
Operating Environment	0°C to 40°C (32°F to 104°F), 80% RH or less, Non-condensing
Power Supply	Six 1.5V AA size Alkaline Batteries
Battery life	5.5 Hours
Dimensions / Weight	198 x 94 x 49 mm (approx.) / 505gms Including Battery (approx.)
Accessories	Alligator Clip Type Test Lead with Temperature Sensor x1, Pin Type Test Lead x 1, DC Current Adaptor x 1, Zero Adjustment Board x 1, Instruction Manual x 1, Batteries (installed), AC Adaptor x 1, Optical USB Cable x 1, PC Software Disk x 1, Carrying Bag x 1, Optional : Thermal Printer x 1

Resistance Measurement

Range	Resolution	Measurement Current	Accuracy
4mΩ	1mΩ	40mA approx.	± (3% reading ± 20 digits)
40mΩ	10mΩ	40mA approx.	
400mΩ	100mΩ	4mA approx.	± (0.8% reading ± 6 digits)
4Ω	1mΩ	400μA approx.	
40Ω	10mΩ	40μA approx.	
400Ω	100mΩ	4μA approx.	

Measuring Current Frequency : 1KHz ± 30Hz

Voltage Measurement

Range	Resolution	Accuracy
6V	1mV	± (0.1% reading ± 6 digits)
60V	10mV	

Maximum Input Voltage : 60VDC maximum. No AC Voltage Input.

Temperature Measurement

Range	Resolution	Accuracy
-20°C to 60°C	0.1°C	± 1.0°C
-4°F to 140°F	0.1°F	± 1.8°F

DC Current Measurement

Range	Sensitivity	Resolution	Accuracy
4A	6mA ~ 4A	1mA	± (2.0%rdg ± 2dgts)
30A	60mA ~ 30A	10mA	± (2.0%rdg ± 3dgts)
600A	0.6A ~ 600.0A	0.1A	± (2.0% rdg ± 2 dgts)

Zero Adjustment Using Pin Type Test Lead

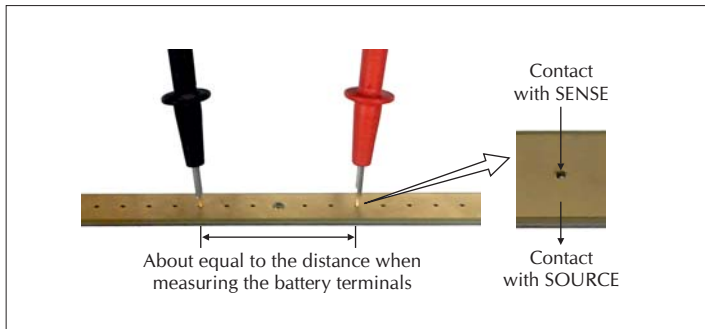

Input Terminals

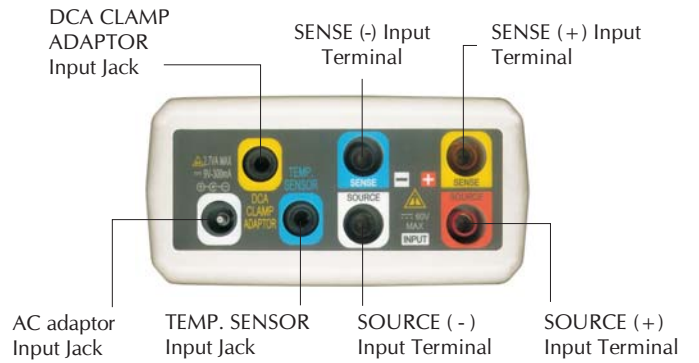

Usage



Zero Adjustment Using Clip Type Test Lead

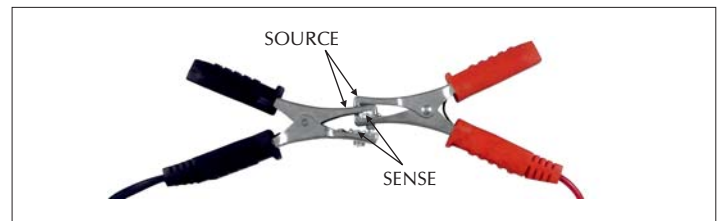

Product Kit



MECO®

SINCE 1962

Solar Analyzers



Reliable, Long-Lasting and Affordable Instruments ...since 1962 !

www.mecoinst.com

An ISO 9001-2008 Certified Company

MECO INSTRUMENTS PRIVATE LTD.

NAVI MUMBAI

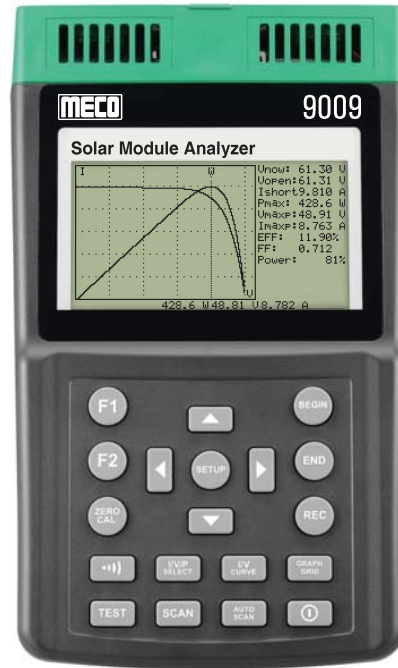

Solar Panels

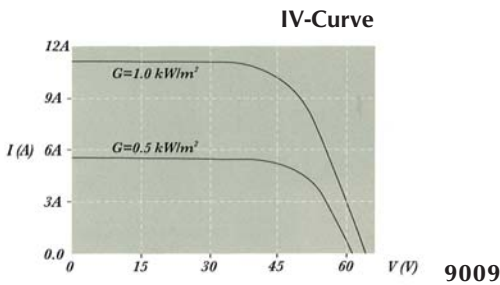

MECO Solar Module Analyzer Model 9009 is a portable analyzer used for testing, maintenance and finding efficiency of various parameters of solar panels and cells. Analyzer can be used to design Solar System to generate specific power. It can identify Solar Power System requirement, best angle of Solar Panel installation and Broken / Worn-out cells

Features

- I-V Curve Test for Solar Panel/Module/Cell
- Max. Solar Panel/Module/Cell Power (Pmax) search by Auto-Scan: 60V, 12A z(500W Capability)
- Best Resolution: 1mV, 1mA
- Manual Single Point I-V Test
- Max. Voltage (Vmaxp) at Pmax
- Max. Current (Imaxp) at Pmax
- Voltage at Open Circuit (Vopen)
- Current at Short Circuit (Ishort)
- I-V Curve with Cursor to Display each Data Point
- Efficiency (%) Calculation of Solar Panel
- Solar Panel Area Setting: 0.001 m² ~ 9999 m²
- Standard Light Source Setting: 10 W/m² ~ 1000 W/m²
- Communicate with PC via USB Cable
- AC Adaptor and Rechargeable Lithium Battery
- Memory Size: 100 Records
- Sampling Time of Data Logging: 0 ~ 99 min.
- Large LCD with Baflight

IV-Curve

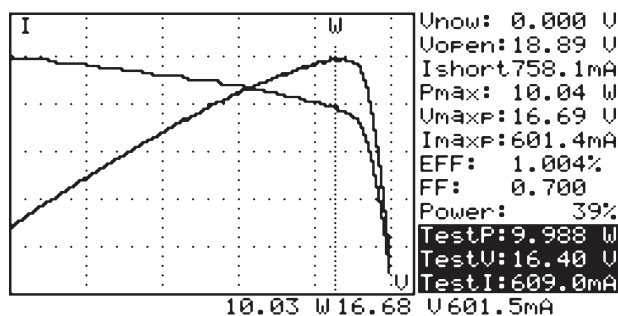

General Specifications

Battery Type	Rechargeable Lithium Battery, 3400mAh
Battery Life	400 times of linear scan from 60V to 0V and 0A to 12A.
Data Logging Memory Size	100 records
AC Adaptor	AC 110 ~ 240V Input, DC 15V / 1 ~ 3A Output
Dimension	257 x 155 x 57mm (approx.)
Weight	1160gms Including Battery (approx.)
Operation Environment	0°C ~ 50°C, 85% RH
Temperature Coefficient	0.1% of full scale / °C (< 18°C or > 28°C)
Storage Environment	-20°C ~ 60°C, 75% RH
Accessories	User Manual x 1, AC Adaptor x 1, Optical USB Cable x 1, Rechargeable Lithium Battery x 1, Software CD x 1, Software Manual x 1, Kelvin Clips (12A max) x 1 Set, 4 Wire to 2 Wire Connector (10A Max, 12A for 1minute) x 1 set, Carrying Bag x 1

Electrical Specifications (23°C ± 5°C, Four-Wire Measurement
Maximum Power Limit is 500W)

DC Voltage Measurement

Range	Resolution	Accuracy
0 – 10V	0.001V	±1% ±(1% of Vopen ± 0.1V)
10 – 60V	0.01V	±1% ±(1% of Vopen ± 0.1V)

Vopen : Open Circuit Voltage of Solar Cell or Module

DC Current Measurement

Range	Resolution	Accuracy
0.01 – 10A	1mA	±1% ±(1% of Ishort ± 9mA)
10 – 12A	10mA	±1% ±(1% of Ishort ± 0.09A)

Ishort : Short Circuit Current of Solar Cell or Module

DC Current Simulation

Range	Resolution	Accuracy
0.01 – 10A	1mA	±1% ±9mA
10 - 12A	10mA	±1% ±0.09A

Rear Panel Connections



User Interface & Data Acquisition Software

Solar Module Analyzer is supplied with user friendly software for Data Storing and Analysis. Users can store Data (.CSV/.TAB) that can be read in MS EXCEL and Print Waveform / Graph via Printer

Software Window

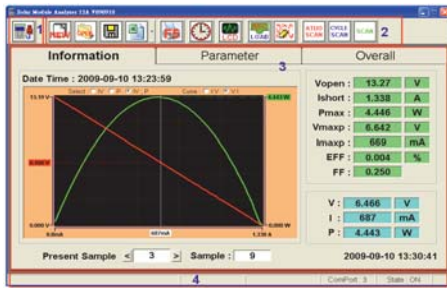

Cycle Scan

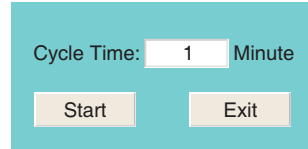

Print LCD

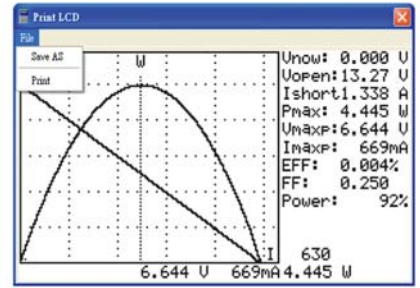

Applications

- Quality Control at Production Line, Warehouse or Site of Installation
- Identify Requirements of Solar Power System
- Maintenance of Solar Panels
- Verify the Best Installation Angles of Solar Panels
- Research and Development

4 Wire Measurement



Solar Panel Connections



Product Kit



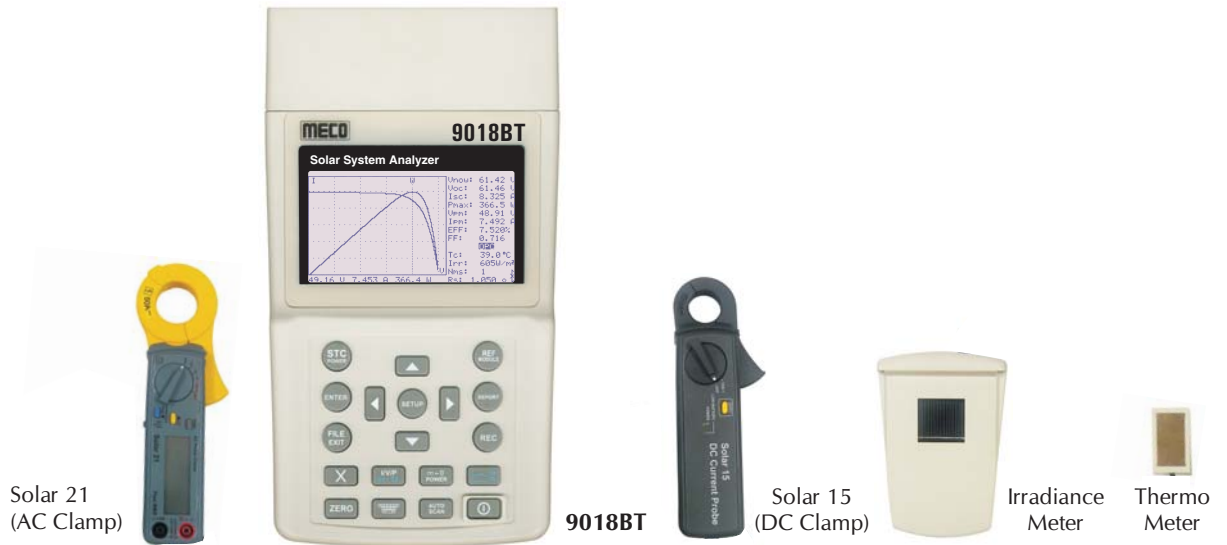

MECO Solar System Analyzer Model 9018BT is Portable Analyzer used for Testing, Monitoring, Measuring, Analyzing and Troubleshooting various parameters of Solar System. This System has Intelligent Test Logic with no personal attendance required. The System continuously monitor DC Output of Solar System and AC Power Output of Inverter, Calculate Efficiency of DC to AC Power Conversion and Maximum Output Power.

Features

- I-V Curve Test for Solar System
- Max. Solar System Power (Pmax) search by Auto-Scan : 1000V, 12A (12000W Capability)
- The Analyzer and the Remote Solar Detector is connected by Bluetooth Wireless Communication (Bluetooth 2.1 + EDR Class 1)
- The Remote Solar Detector is Moisture-Proof.
- Intelligent Test Logic with no personnel attendance required in the field.
- Solar System Analyzer waits and tests the system until appropriate Sunlight Irradiance is detected.
- Max. Voltage (Vpm) at Pmax, Max. Current (Ipm) at Pmax
- Voltage at Open Circuit (Voc), Current at Short Circuit (Isc)
- Efficiency (%) Calculation of Solar System
- Temperature Measurement of Solar Panels
- Irradiance Measurement of Sun Light
- Series Resistance (Rs) Calculation of Solar Panels
- With Data Logging/Open Function, the I-V Curves of Solar System can be analysed / recorded for a period of time (e.g. 60 min.)
- Conversion of I-V Curve under OPC to data under Standard Test Condition (STC) based upon IEC Standard
- Built-in Calendar Clock
- Users can set up the Parameters of Solar Panels
- Users can set up the Series number of Solar Panels. Parameters of many Solar Panels can be Measured in One Measurement.
- The Irradiances and Temperatures of Solar Panels can be continuously Measured, Monitored and Recorded.
- Rechargeable Lithium Battery, Low Battery Warning, AC Power Adaptor
- Optical USB Cable for PC Communication
- Solar Connector (optional)
- Provide Operating Condition (OPC) and Standard Test Condition (STC) test reports for Verification of Solar Panel Performance (OK, or NO OK)
- With Power Clamps (SOLAR 15 DC Current Probe and SOLAR 21 AC Power Clamp), continuously measure / monitor / record the DC Power output of Solar System and the AC Power Output of Inverter (1 phase or balanced 3 phases); calculate the Efficiency of DC to AC Power Conversion and the Efficiency of the max. output power.

Top & Rear Panel Connections

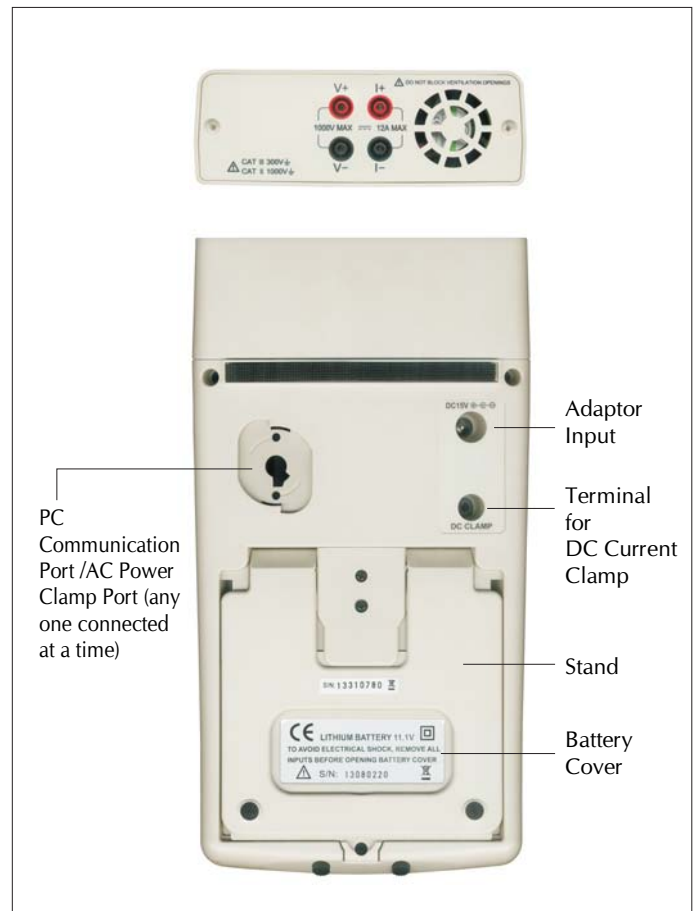

General Specifications for Solar System Analyzer

Battery Type	Rechargeable Lithium Battery (3400mAh)
Battery Life	400 times of linear scan (1000V ~ 1V, 0.1A ~ 12A), 8 hours for standby mode.
Memory Size	512K Bytes (3980 Mod files or 320 REC files or 3980 PWR files or 3980 IRR files)
AC Adaptor	AC 100 ~ 240V input, DC 15V / 1 ~ 3A output
Dimension	260 x 158 x 64mm (approx.)
Weight	1580gms Batteries included (approx.)
Operation Environment	50°C ~ 50°C, 85% RH
Temperature	0.1% of full scale / °C
Coefficient	(< 18°C or > 28°C)
Storage Environment	-20°C ~ 60°C, 75% RH
Accessories	Solar Irradiance Meter (Remote Solar Detector) x 1, Thermometer x1, USB power cord x1, User manual x1, AC adaptor x1, Optical USB cable x1, Rechargeable lithium battery (3400mAh) x1 (installed), Software CD x1, Software manual x1, Carrying bag x1, Thermal conductive gel x1, Testing clips (1 black & 1 red), Extension Cable x 1, 4-wire to 2-wire connecting cable x1, 4-wire testing cable x1, Solar 15 : DC current probe x1, Solar 21: AC power clamp x1, Optional : Solar Connector (1 black & 1 red)

Electrical Specifications (23°C ± 5°C, Irradiance ≥ 800W/m²,
Four-Wire Measurement, Maximum
Power Limit is 12000W)

DC Voltage Measurement

Range	Resolution	Accuracy
0 ~ 1000V	0.01 V / 0.1 V / 1 V	±1% ±(1% of Voc ± 0.1 V)

Voc : open circuit voltage of solar system

DC Current Measurement

Range	Resolution	Accuracy
0.1 ~ 12A	1mA / 10mA	± 1% ±(1% of Isc ± 9mA)

Isc : short circuit current of solar system

DC Current Simulation

Range	Resolution	Accuracy
0.1 ~ 12A	1mA / 10mA	± 1% ± 9mA

Irradiance Measurement

Range	Resolution	Accuracy
0 ~ 2000W/m ²	1W/m ²	± 3% ± 20dgt

Temperature Measurement

Range	Resolution	Accuracy
-22 ~ 85°C	0.1°C	± 1% ± 1°C

Electrical Specifications for AC Power Clamp (Solar 21)

AC Watt (50 or 60Hz, PF 0.6 to 1. CT = 1, Accuracy of Readings)		
Range (0 to 30A)	Resolution	Accuracy of Readings
0.050 - 9.999W	0.001W	± 2% ± 0.025W
10.00 - 99.99W	0.01W	± 2% ± 0.25W
100.0 - 999.9W	0.1W	± 2% ± 2.5W
1.000 - 9.999KW	0.001KW	± 2% ± 0.025KW
10.00 - 99.99KW	0.01KW	± 2% ± 0.25KW
100.0 - 999.9KW	0.1KW	± 2% ± 2.5KW
1000 - 9999KW	1KW	± 2% ± 25KW

Conversion of OPC Data into STC Data

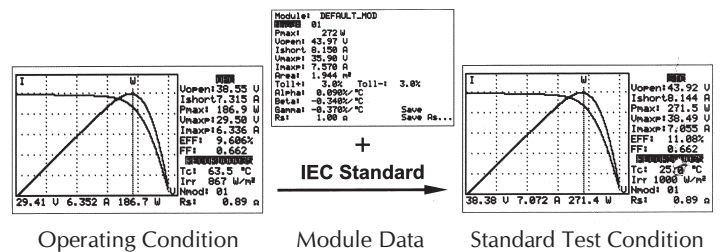

AC Power Clamp (Solar 21)

Features

- Active (W, KW, HP), Reactive (VAR, KVAR) & Apparent (VA, KVA) Power
- Power factor (PF), Phase angle (Φ), & Energy (mWH, WH, KWH)
- Measurement of standby power consumption for IT products
- Non-interrupted AC current harmonic analysis
- 1 to 99th order of harmonics at 1.0% basic accuracy
- Total harmonic distortion (%THD-F) & crest factor (CF)
- True RMS measurement of V & A at 0.5% basic accuracy
- Fast peak function (39μs for 50Hz, 33μs for 60Hz)
- Measurement of balanced 3Φ power
- Measurement of balanced 3Φ sequence
- Programmable CT ratio from 1 to 250
- Max, Min & Data hold functions
- Leakage current measurement at 10μA resolution
- Active power in H.P.
- Shielded jaw immune to external interference

AC Voltage (50 or 60Hz, True RMS)			
Range	Resolution	Accuracy (50 or 60Hz)	Accuracy (45 - 1KHz)
5 - 250V	0.1 V	±0.5% ± 5 dgt	± 1.5% ± 5 dgt
250 - 600V			

Harmonics of AC Voltage in % & Magnitude (1 - 99th order)				
Range	Resolution in %	Accuracy in %	Resolution in Magnitude	Accuracy in Magnitude
1 - 10th	0.1 %	± 1% of reading ± 1%	0.1V	± 1% of reading ± 7 dgts
11 - 20th		± 5% of reading ± 1%		± 5% of reading ± 7 dgts
21 - 50th		± 15% of reading ± 1%		± 15% of reading ± 7 dgts
51 - 99th		± 35% of reading ± 1%		± 35% of reading ± 7 dgts

Harmonics of AC Current in % & Magnitude (1 - 99th order)				
Range	Resolution in %	Accuracy in %	Resolution in Magnitude	Accuracy in Magnitude
1 - 10th	0.1 %	± 1% of reading ± 1%	0.01mA/ 0.1mA/ 0.001A/ 0.01A	reading in mA : ± 1% of reading ± 2mA reading in A : ± 1% of reading ± 0.3A
11 - 20th		± 5% of reading ± 1%		reading in mA : ± 7% of reading ± 2A reading in A : ± 7% of reading ± 0.3A
21 - 50th		± 15% of reading ± 1%		reading in mA : ± 15% of reading ± 3mA reading in A : ± 15% of reading ± 0.3A
51 - 99th		± 35% of reading ± 1%		reading in mA : ± 35% of reading ± 3mA reading in A : ± 35% of reading ± 0.3A

Frequency (Hz)			
Range	Resolution	Accuracy of Readings	Allowed Input
mA (45 - 65Hz)	0.1 Hz	± 0.5Hz	20mA - 1.2A
A (45 - 65Hz)			1A - 100A

Power Factor (PF, ACV > 4V, AC mA > 1mA, AC A > 0.04A, Watt > 50dgts) & Phase Angle (Φ, 50 or 60Hz)		
Range	Resolution	Accuracy
0.000 - 1.000	0.001	± 0.04
-180° to 180° & 0° to 360°	0.1°	± 2°

AC Watt (50 or 60Hz, PF 0.6 to 1. CT = 1, Accuracy of Readings)		
Range (30 to 50A)	Resolution	Accuracy
0.050 - 9.999W	0.001W	± 2% of VA ± 5 dgts
10.00 - 99.99W	0.01W	
100.0 - 999.9W	0.1W	
1.000 - 9.999KW	0.001KW	
10.00 - 99.99KW	0.01KW	
100.0 - 999.9KW	0.1KW	
1000 - 9999KW	1KW	

Total Harmonic Distortion (THD-F, 1 - 50th order)		
Range (45 to 65Hz)	Resolution	Accuracy
0.0 - 10.0%	0.1 %	± 2%
10.0 - 40%		± 5% of reading ± 5%
40 - 100%		± 10% of reading ± 10%
100 - 999.9%		± 20% of reading

Peak Value of AC Periodic Voltage or AC Periodic Current		
Range	Sampling Time	Accuracy of Readings
50Hz	39μs	± 5% ± 30 dgts
60Hz	33μs	

Crest Factor (C.F., Accuracy of Readings)		
Range	Resolution	Accuracy of Readings
1.00 - 99.99	0.01	± 5% ± 30 dgts

Product Kit



DC Current Probe (Solar 15)

Features

- Accurate DC Current Probe for Current Measurement
- One Touch Zero for DCA adjustment
- 23mm Diameter Jaw

Electrical Specifications for DC Current Probe (Solar 15)

Range	Resolution	Accuracy
DC 12A	1mA / 10mA	± 2.0% ±30mA

Applications

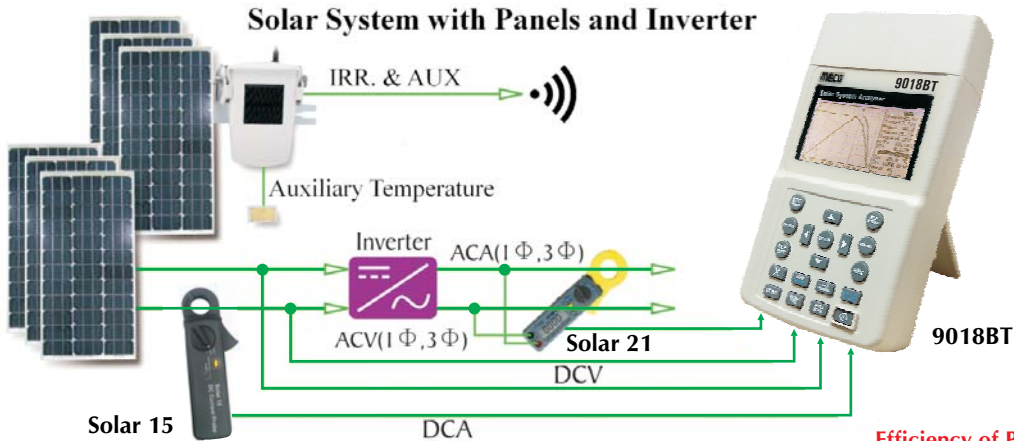

A. Quality Control at Production Line, Warehouse or Site of Installation

- Manufacturers of solar panels can test the characteristics for quality control purpose at the production line.
- Installation engineers can randomly test samples of solar panels at site to verify the quality of solar panels used at site of installation.

B. Identify Requirements of Solar Power System

- The unit can measure actual max. power (Pmax), voltage (Vpm) and current (Ipm) at max. power.
- Instead of the rated max. power, system designers need to be aware of the actual solar power from solar panels under actual operating conditions.

C. Maintenance of Solar Panels

- Maintenance engineers can store the characteristics data of solar panels in the beginning. And compare the characteristics data in weekly, monthly or yearly maintenances.

D. Verify the Best Installation Angles of Solar Panels

- Engineers can collect data of the installation angles at different dates and time by using the unit at site of installation.
- The data can be used as a reference to design the automated angle adjustment system or the data can be used to select an optimal angle for a fixed angle installation.

E. Measure / Monitor / Record the DC Power Output & Efficiency

- Continuously Measure / Monitor / Record the DC power output of solar system and the AC power output of inverter (1 phase or balanced 3 phases)
- Calculate the efficiency of DC to AC power conversion and the efficiency of the max. output power

Efficiency of Power Mode

DC POWER		AC POWER 1P2W	
Voc: 82.15 U	P: 335.2 W	V: 309.3 U	P: 112.8 W
Isc: 5.880 A	U: 70.40 U	I: 2.750 A	P: 4.761 A
Pmax: 347.3 W	U: 4.761 A	I: 0.997	
Upm: 70.43 U	EFF(Pmax): 96.5%	EFF(DC-AC): 92.3%	
Ipm: 4.931 A	EFF: 97.2%	EFF: 93.1%	
Irr: 1050W/m²	Alpha: 0.090/°C	P: 313.2 W	FF: 0.997
Tc: 51.2°C	Beta: -0.340/°C	Gamma: 0.370/°C	Battery: 100%
Phi: 28.1 W/h	Phi: 28.1 W/h	Phi: 28.1 W/h	

Normal I-V Curve

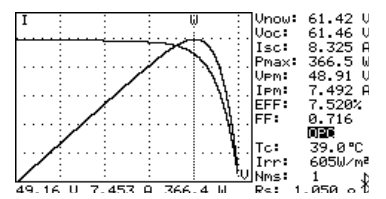

Abnormal I-V Curve (Cells at the corner of solar panel are defected)

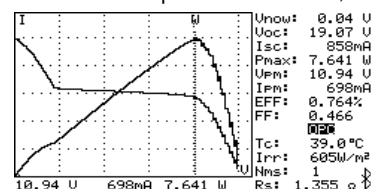

User Interface and Data Acquisition Software

File List

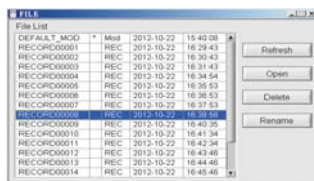

Print LCD

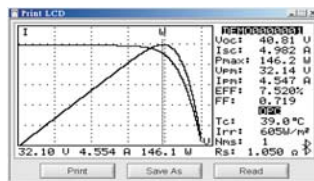

Cycle Scan



Solar Panel Test report

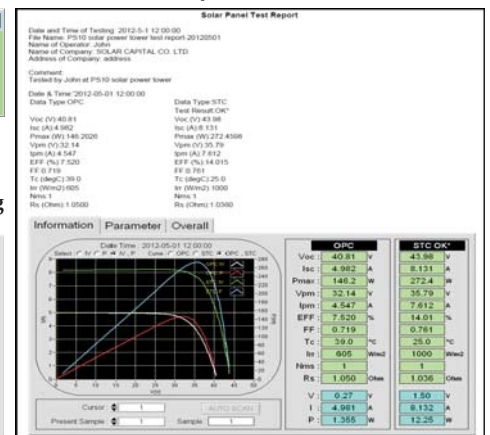

Setup

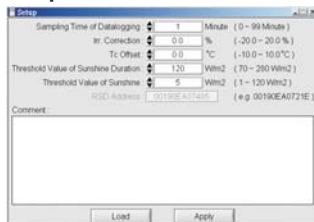

Power Curves

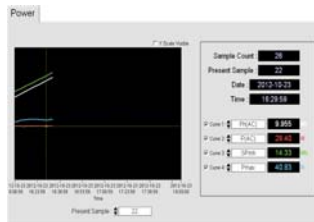

Irradiance / Temperature Recording

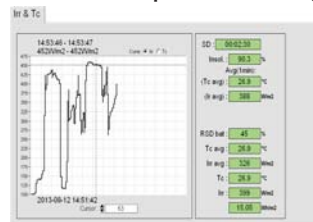



936

Applications

- Solar Power Plant
- Solar Radiation Measurements
- Solar Power Research for Location of the Solar Panels or Solar Water Heaters
- Physics and Optical Laboratories
- Meteorology
- Agriculture
- Windows Performance Calculate the Rate of Daylight Penetration

Features

- Solar Power Measurement with Orientation and Tilt Angle
- Measurement : Solar Power (illuminance), Orientation, Tilt Angle
- Solar Power Measurement Range : 2000 W/m² or 634 BTU / (ft².h)
- Easy Measurement for Rate of Daylight Penetration
- Auto Change for Measuring Range
- Auto Power off with Disable Function
- Instantaneous, Average, Min/Max Values, Data Hold
- 20 Points Memory, Low Battery Indicator
- Socket for Tripod Mounting
- Operation with 9V Battery
- Magnetic Mount
- Backlit LCD and 4 Digits Triple Display

Specifications

Sensor	High Sensitivity Silicon Photodiode
Spectral Response	400 ~ 1100 nm
Range	0 ~ 2000 W/m ² (0 ~ 634 BTU / ft ² .h)
Accuracy (at 23°C, 60% RH)	±10W/m ² (±3 BTU/ ft ² .h) or ±5% (whichever is greater)
Resolution	0.00 ~ 99.99 W/m ² : 0.01 W/m ² ,
	100.0 ~ 999.9 W/m ² : 0.1 W/m ² , 1000 ~ 2000 W/m ² : 1 W/m ²
	0.00 ~ 99.99 BTU/ft ² .h : 0.01 BTU/ ft ² .h, 100.0 ~ 634.0 BTU/ft ² .h : 0.1 BTU/ ft ² .h
Angular Accuracy	Cosine Corrected < 7% (angle < 60°)
Tilt Angle Range	0 ~ 90°
Tilt Angle Accuracy (at 23°C, 60% RH)	± 1.2° (≤ 60°), Additional Temperature Induced Error ±0.1°/°C from 23°C
Sample Time	Approx. 0.4 Second
Operation Temp. & Relative Humidity	0°C ~ 50°C (32°F ~ 122°F) Less than 80% RH
Store Temp. & Relative Humidity	-10°C ~ 60°C (14°F ~ 140°F) Less than 85% RH
Auto Power Off	Enable or Disable (Auto Power off after approx. 10 minutes)
Battery Life	Approx. 30 Hours for Continuous Use
Max / Min / Avg	Yes
Data Hold	Yes
Low Battery Indication	Yes
Backlight Function	Yes
Zero Adjustment	Yes
Over Range Indication	Yes (“-HI-”)
Memory	Yes (20 Points Memory)
Compass	Yes
Solar Transmission Measurement	Yes
Tripod Socket	Yes
Weight	220gms Including Battery (approx.)
Dimensions	Main Instrument : 140 x 49 x 29 mm (approx.)
	Sensor Probe : 83 x 54 x 26 mm (approx.)
Accessories	9V Battery, Instruction Manual, Carrying Case

MECO®

SINCE 1962

Environment Testing Instruments



Reliable, Long-Lasting and Affordable Instruments ...since 1962 !

www.mecoinst.com

An ISO 9001-2008 Certified Company

MECO INSTRUMENTS PRIVATE LTD.

NAVI MUMBAI



IRT380P



IRT550P



IRT1050P

Temperature Range	-50°C ~ 380°C	-50°C ~ 550°C	-50°C ~ 1050°C
	-58°F ~ 716°F	-58°F ~ 1022°F	-58°F ~ 1922°F
Accuracy	± 1.5°C	± 1.5°C	± 1.5°C
Distance Spot Ratio	12 : 1	12 : 1	50 : 1
Emissivity	0.95	0.95	0.10 ~ 1.00 (Adjustable)
Repeatability	±0.5°C or 1%	±0.5°C or 1%	±0.5°C or 1%
Wavelength	630 ~ 670nm	630 ~ 670nm	630 ~ 670nm
Resolution	0.1°C / 0.1°F	0.1°C / 0.1°F	0.1°C / 0.1°F
Spectral Response	6μm ~ 14μm	6μm ~ 14μm	8μm ~ 14μm
Special Function			
°C / °F Selection	✓	✓	✓
Laser Switch	✓	✓	✓
Auto Power Off	✓	✓	✓
Low Battery Indication	✓	✓	✓
Backlight Display	✓	✓	✓
MAX Function	✓	✓	✓
MIN Function	✓	✓	✓
DIF Function	-	-	✓
AVG Function	-	-	✓
Data Storage	-	-	✓
High / Low Temperature Alarm Settings Function	-	-	✓
LCD Size	30 x 31mm	30 x 31mm	36 x 27mm
Packing Information			
Power	9V Battery	9V Battery	9V Battery
Product Color	Yellow + Black	Yellow + Black	Yellow + Black
Product Size	170 x 92 x 46mm (approx.)	170 x 92 x 46mm (approx.)	235 x 130 x 54mm (approx.)
Product Net Weight	157gms including battery (approx.)	157gms including battery (approx.)	278gms including battery (approx.)
Accessories	Carrying Case x 1, Instruction Manual x 1, 9V Battery (installed) x 1	Carrying Case x 1, Instruction Manual x 1, 9V Battery (installed) x 1	Heavy Duty Carry Box x 1, Instruction Manual x 1, Tripod Stand x 1, 9V Battery (installed) x 1



TIC300

TIC300 is a Thermal Imaging Camera which combines the functions of surface temperature measurement and real-time thermal imaging.

Traditional Thermal Imaging Cameras measure each component one by one but TIC300 does it together thus saving customer's time. The potential problem is clearly displayed on the color screen which helps customer to quickly locate the central point and temperature of the problem area.

To improve recognition, this product is equipped with a vision camera. Based on practical requirements, it can turn thermal image into visual image. Thermal image and visual image can be stored in the memory card. Adjust the images and store them in PC which are used to generate reports or for printing. After seconds it can be tested. This product is the optimum product for electrician and maintenance personnel. It can quickly find out the problem area.

Specifications

Display	2.4" Color Display
Resolution	60 X 60
Total Pixels	3600
FOV / Shortest Focal Length	20° x 20° / 0.5m
Thermal Sensitivity	0.15 °C
Measuring Mode	Infrared Focal Plane Measuring Temperature
Temperature Range	-20°C ~ 300°C (-4°F ~ 572°F)
Measuring Accuracy	± 2% digital / ± 2°C
Wavelength Range	8 ~ 14 μm
Image Capturing Frequency	6 Hz
Emissivity	0.1 ~ 1.0 (Adjustable)
Focus Mode	Fixed
Palette	Iron Red Color, Rainbow, Rainbow High Contrast, Grey Scale (White Glow) and Grey Scale (Black Glow)
Image Storage	Card (4GB)
Memory Card	Micro SD Card (installed)
File Format	BMP
Set Control	Unit Adjustment / Language / Date Time Format / Automatic Shutdown
Battery Type	AA x 4 Batteries
Battery Life	6 Hours
Operating Temp.	-5°C ~ 40°C
Storage Temperature	-20°C ~ 50°C
Relative Humidity	10% RH ~ 80% RH
Vibration	2G, IEC 60068 - 2 - 6
Drop resistance	2m
Size	212 x 95 x 62mm (approx.)
Weight	320gms (approx.)
Accessories	Carrying Case, Inst. Manual, Micro SD Card (installed), AA x 4 Batteries (Installed)

Applications

- Predictive Maintenance of Electrical Equipment
- Transport Industry and Car Maintenance
- Electronic & Electrical Manufacturing
- Archaeological Study
- Automotive Manufacturing
- Furnace & Smelting



Air Conditioner



Air Cooler



Vehicle Maintenance



Hot Kettle



Electrical Switchgear



930T

Digital LUX Meter

Functions	MAX / MIN, Backlight, Auto Power Off with Disable Feature, Data Hold
Range	0.1 ~ 200,000 lux 0.0 ~ 20,000 fc
Accuracy	±3% + 30 dgt
Resolution	0.1 lux or 0.1 fc
Selection	lux / fc
Power	1.5V AAA x 2 Batteries
Dimension	157 x 54 x 34mm (approx.)
Weight	170gms Including Battery (approx.)
Accessories	Carrying Case, Inst. Manual, 1.5V AAA x 2 Batteries (installed)



910

Infrared Thermometer

IR Temperature	
Functions	HOLD / MAX / MIN / MAX-MIN / AVG / APO
Range	-30°C ~ 550°C, -22°F ~ 1022°F
Accuracy	±(2°C / 4°F) for -30°C ~ 100°C, (-22°F ~ 212°F) ±(2% reading) for 101°C ~ 550°C (213°F ~ 1022°F)
Resolution	0.1°C, 0.1°F
Emissivity (ε)	0.1 ~ 1.0 (Adjustable)
Air Temperature	
Range	-20°C ~ 60°C, (-4°F ~ 140°F)
Accuracy	±0.5°C for 0°C ~ 45°C, ±1.0°C for -20°C ~ 0°C, 45°C ~ 60°C, ±1.0°F for 32°F ~ 113°F, ±2.0°F for -4°F ~ 32°F ~ 113°F ~ 140°F
Resolution	0.1°C, 0.1°F
Power	1.5V AAA x 2 Batteries
Dimensions	25 x 51 x 133mm (approx.)
Weight	125gms Including Battery (approx.)
Accessories	1.5V AAA Battery (installed) x 2 Wristlet x 1, Protection Cap x 1



961

Hygro Anemometer

Wind Velocity	
Functions	HOLD / MAX / MIN / MAX-MIN / AVG / APO
Range	0.4 ~ 20 m/s, 80 ~ 4000 ft/m
Accuracy	±0.2 m/s + 2% of reading, ±40 ft/m + 2% of reading
Resolution	0.1 m/s, 1 ft/m
Relative Humidity	
Range	0% ~ 100% RH
Accuracy	±2.5%, 10 ~ 90% RH [at 25°C (77°F)] ±5%, 0 ~ 10% RH, 90% ~ 100% RH
Air Temperature	
Range	-20°C ~ 60°C, -4°F ~ 140°F
Accuracy	±0.5°C for 0°C ~ 45°C, ±1.0°C for -20°C ~ 0°C, 45°C ~ 60°C, ±1.0°F for 32°F ~ 113°F, ±2.0°F for -4°F ~ 32°F ~ 113°F ~ 140°F
Resolution	0.1°C, 0.1°F
Power	1.5V AAA x 2 Batteries
Dimensions	25 x 51 x 133mm (approx.)
Weight	135gms Including Battery (approx.)
Accessories	1.5V AAA Battery (installed) x 2, Wristlet x 1, Protection Cap x 1



920

Thermo Hygrometer

Humidity Measuring	
Functions	HOLD / MAX / MIN / MAX-MIN / AVG / APO
Range	0% ~ 100% RH
Accuracy	±2.5% for 10% ~ 90% RH [at 23±5°C (73.4±9°F)] ±5% for 0 ~ 10% RH, 90 ~ 100% RH
Temperature Measuring	
Range	-20°C ~ 60°C (-4°F ~ 140°F)
Accuracy	±0.5°C for 0°C ~ 45°C, ±1.0°C for -20°C ~ 0°C, 45°C ~ 60°C, ±1.0°F for 32°F ~ 113°F, ±2.0°F for -4°F ~ 32°F, 113°F ~ 140°F
Resolution	0.1°C / °F
Power	1.5V AAA x 2 Batteries
Dimensions	25 x 51 x 133mm (approx.)
Weight	112gms Including Battery (approx.)
Accessories	1.5V AAA Battery (installed) x 2, Wristlet x 1, Protection Cap x 1



970P

Digital Sound Level Meter

Functions	MAX / MIN / HOLD, Auto Power Off
Range	35dB ~ 130dB (31.5Hz ~ 8 KHz)
Accuracy	± 1.5dB (under reference conditions)
Resolution	0.1dB
Power	9V Battery
Dimension	172 x 56 x 39 mm (approx.)
Weight	144gms Including Battery (approx.)
Accessories	Carrying Case, Inst. Manual, 9V Battery (installed)



930P

Digital LUX Meter

Functions	MAX / MIN, Backlight, Auto Power Off
Range	0 ~ 200,000 lux 0 ~ 20,000 fc
Accuracy	± 5% rdg + 10 dgt (< 10,000 lux/fc) ± 10% rdg + 10 dgt (> 10,000 lux/fc)
Resolution	0.1lux or 0.1fc
Selection	lux / fc
Power	9V Battery
Dimension	190 x 56 x 39mm (approx.)
Weight	135gms Including Battery (approx.)
Accessories	Carrying Case, Inst. Manual, 9V Battery (installed)



961P

Air Flow Anemometer

Air Flow Measuring	
Functions	m / Sec, Ft / min, Knots, Km / h, MPH, CFM, MAX / MIN / HOLD, Auto Power Off
Range	1 ~ 25m/s
Accuracy	± (3% rdg ± 0.2m/s)
Resolution	0.01m/s
Temperature Measuring	
Range	0 ~ 50°C, 32 ~ 122°F
Accuracy	± 2°C / ± 4.0°F
Resolution	0.1°C / 0.1°F
Power	9V Battery
Dimension	202 x 56 x 39mm (approx.)
Weight	155gms Including Battery (approx.)
Accessories	Carrying Case, Inst. Manual, 9V Battery (installed)



920P

Humidity & Temperature Meter

Humidity Measuring	
Functions	°C / °F / RH Selection, MAX / MIN, Auto Power Off
Range	0% ~ 100% RH
Accuracy	± 3%RH (25°C, 20 ~ 80% RH) ± 3.5%RH (At Other Ranges)
Resolution	0.01%RH
Temperature Measuring	
Range	- 20°C ~ 80°C / - 4°F ~ 176°F
Accuracy	± 0.5°C / ± 0.9°F (25°C) ± 0.8°C / ± 1.5°F (At Other Ranges)
Resolution	0.01°C / 0.01°F
Power	9V Battery
Dimension	173 x 56 x 39mm (approx.)
Weight	139gms Including Battery (approx.)
Accessories	Carrying Case, Inst. Manual, 9V Battery (installed)

CE



9810

Electrical Specifications

Sensor Type	Electrical Field (E)
Frequency Range	10MHz to 8GHz
Directional Characteristic	Isotropic, triaxial
Measurement Range CW signal (f > 10MHz)	20mV/m to 108.0V/m, 53µA /m to 286.4mA /m, 1µW/m ² to 30.93W/m ² , 0µW/cm ² to 3.093mW/cm ²
Dynamic Range	Typically 75dB
Absolute Error (at 1V/m and 10MHz)	± 1.0dB
Frequency Response (Taking into Account Typical CAL Factor)	± 1.0dB (10MHz to 1.9GHz), ± 2.4dB (1.9GHz to 8GHz)
Isotropy Deviation	Typically ±1.0dB for f > 10MHz
Overload Limit	10.61mW/cm ² (200V/m)
Thermal Response (0 to 50°C)	± 0.5dB

Features

- Frequency Range 10Mhz to 8.0Ghz
- Triaxial Isotropic Measurement of EMF
- Non-Directional (Isotropic) Measurement with Three-Channel Measurement Sensor
- High Dynamic Range
- Configurable Alarm Threshold and Memory Function
- Easy & Safety to Use

Applications

- High Frequency (RF) Electromagnetic Wave Field Strength Measurement
- Mobile Phone Base Station Antenna Radiation Power Density Measurement
- Wireless Communication Applications (CW, TDMA, GSM, DECT)
- RF Power Measurement for Transmitters
- Wireless LAN (Wi-Fi) Detection, Installation
- Spy Camera, Wireless Bug Finder
- Cellular / Cordless Phone Radiation Safety Level
- Microwave Oven Leakage Detection
- Personal Living Environment EMF Safety

General Specifications

Measurement Method	Digital, Triaxial Measurement
Directional Characteristic	Isotropic, Triaxial
Measurement Range Selection	One Continuous Range
Display Resolution	0.1mV/m, 0.1: A/m, 0.1: W/m ² , 0.001: W/cm ²
Setting Time	Typically 1s (0 to 90% of Measurement Value)
Display Refresh Rate	Typically 0.5 Seconds
Display Type	LCD 4 Digit
Audible Alarm	Buzzer
Measurement Units	mV/m, V/m, µA/m, mA/m, µW/m ² , mW/m ² , W/m ² , µW/cm ² , mW/cm ²
Measurement Display Value	Instantaneous Measured Value, Maximum Value, Average Value or Maximum Average Value
Measurement Alarm Function	Adjustable Threshold with ON/OFF
Calibration Factor CAL	Adjustable
Manual Data Memory and Read Storage	99 Data Sets
Battery	9V x 1
Battery Life	> 3 Hours
Dimensions	68 x 60 x 247 mm (approx.)
Weight	255gms Including Battery(approx.)
Accessories	Battery (installed), Carrying Case x 1 & Instruction Manual x 1



9720

Electrical Specifications

Sensor Type	Electric Field (E)
Frequency Range	50MHz to 3.5GHz
Directional Characteristic	Isotropic, triaxial
Measurement Range CW signal (f > 50MHz)	20mV/m to 108.0V/m, 53µA /m to 286.4mA /m, 1µW/m ² to 30.93W/m ² , 0µW/cm ² to 3.093mW/cm ²
Absolute Error (at 1V/m and 50MHz)	± 1.0dB
Frequency Response (Taking into Account Typical CAL Factor)	± 1.0dB (50MHz to 1.9GHz), ± 2.4dB (1.9GHz to 3.5GHz)
Isotropy Deviation	Typically ±1.0dB for f > 50MHz
Overload Limit	10.61mW / cm ² (200V/m)
Thermal Response (0 to 50°C)	± 0.2dB

Note

Unless otherwise stated, all specifications are Valid under the following assumptions :

- Sinusoidal Signals ● Device in far field of a source
- Sensor head pointing towards source
- Ambient temperature + 23°C ± 3°C (RH < 75%)

Features

- Frequency Range 50MHz to 3.5GHz
- For Isotropic Measurement of Electro Magnetic Fields
- Non-Directional (Isotropic) Measurement with Three-Channel Measurement Sensor
- High Dynamic Range due to Three Channel Digital Results Processing
- Configurable Alarm Threshold and Memory Function
- Easy and Safety to Use

Applications

- High Frequency (RF) Electromagnetic Wave Field Strength Measurement
- Mobile Phone Base Station Antenna Radiation Power Density Measurement
- Wireless Communication Applications (CW, TDMA, GSM, DECT)
- RF Power Measurement for Transmitters
- Wireless LAN (Wi-Fi) Detection, Installation
- Spy Camera, Wireless Bug Finder
- Cellular / Cordless Phone Radiation Safety Level
- Microwave Oven Leakage Detection
- Personal Living Environment EMF Safety

General Specifications

Measurement Method	Digital, Triaxial Measurement
Directional Characteristic	Isotropic, Triaxial
Measurement Range Selection	One Continuous Range
Display Resolution	0.1mV/m, 0.1µA/m, 0.1µW/m ² 0.001µW/cm ²
Setting Time	Typically 1s (0 to 90% of Measurement Value)
Display Refresh Rate	Typically 0.5 Seconds
Display Type	LCD 4 Digit
Audible Alarm	Buzzer
Measurement Units	mV/m, V/m, µA/m, mA/m, µW/m ² , mW/m ² , W/m ² , µW/cm ² , mW/cm ²
Measurement Display Value	Instantaneous Measured Value, Maximum Value or Maximum Average Value
Measurement Alarm Function	Adjustable Threshold with ON/OFF
Measurement Calibration Factor CAL	Adjustable
Manual Data Memory and Read Storage	99 Sets (only Recall by Meter)
Battery	9V x 1
Battery Life	> 15Hours
Dimension	60 x 60 x 237mm (approx.)
Weight	210gms Including Battery (approx.)
Accessories	Battery (installed), Carrying Case x 1 & Instruction Manual x 1



Functions

- Addition / Subtraction
- Area Measurement
- Volume Measurement
- Pythagorean Measurement
- Laying Off
- Data Storage / Paging Out

Display Screen

1. Laser On Indicator
2. Reference Edge Measuring Indicator
3. Area/Volume/Legs of A Triangle Laying Off Indicator
4. Laying Off Function Indicator
5. Battery Level Indicator
6. Data Storage Indicator
7. Data Storage Number Indicator
8. Signal Strength Indicator
9. Unit Indicator
- (Including Power and Cube)
10. Secondary Display Area
11. Main Display Area

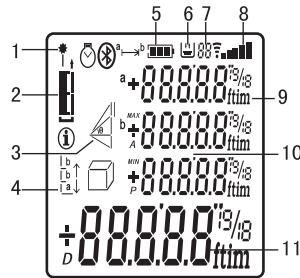

LDM60



LDM100



Applications



Specifications

Model	LDM60	LDM100
Range	0.05 ~ 60m	0.05 ~ 100m
Measuring Accuracy up to 60 / 100m (in the room)	± 1.5mm	± 1.5mm
Measurement Time	0.1 ~ 3 Sec	0.1 ~ 3 Sec
Units	Meter / Inches / Feet	Meter / Inches / Feet
Smallest Unit Displayed	1mm	1mm
Laser Class	Class II	Class II
Laser Type	635nm, < 1mw	635nm, < 1mw
Automatic Switch Off	8 Minutes Of Inactivity	8 Minutes Of Inactivity
Display Illumination (Backlight)	✓	✓
Min / Max, Measurement / Continuous Measurement	✓	✓
Addition / Subtraction	✓	✓
Pythagoras Measurement	✓	✓
Area / Volume Calculation	✓	✓
Triangular Area Measurement	✓	✓
Historical Storage	✓ (20)	✓ (20)
Storage Temperature	-25°C ~ 60°C	-25°C ~ 60°C
Operating Temperature	0°C ~ 40°C	0°C ~ 40°C
Power	1.5V AAA x 2 Batteries	1.5V AAA x 2 Batteries
Battery Life	Up to 15000 Measurements	Up to 15000 Measurements
Rating (Dust Proof & Water Proof)	IP54	IP54
Product Size	116 x 52 x 28mm	116 x 52 x 28mm
Product Weight	104gms	104gms
Accessories	Carrying Case, Inst. Manual, 1.5V AAA x 2 Batteries (installed)	Carrying Case, Inst. Manual, 1.5V AAA x 2 Batteries (installed)

MECO®

SINCE 1962

Power & Harmonics Analyzers



Reliable, Long-Lasting and Affordable Instruments ...since 1962 !

www.mecoinst.com

An ISO 9001-2008 Certified Company

MECO INSTRUMENTS PRIVATE LTD.

NAVI MUMBAI



MAHANAGAR GAS LTD.

(Joint Venture of GAIL, British Gas, U.K. & Govt. of Maharashtra)

30 DEC 2011
City Gate Station,
Opp. Anik Depot,
Sion, Mumbai - 400 022.
Tel. : 2404 5785 • Fax : 2401 0080

Date: December 26, 2011

To,
Mr. Kamal Goliya – C.E.O.
M/s. Mecco Instruments Pvt. Ltd.
Plot No. 1, MIDC Electronic Zone,
TTC Industrial Area, Mahape, Navi Mumbai – 400 710
Tel. No. 022 – 27673300 Fax No. 022 – 27673310

Dear Sir,

Sub. Training, Live Demonstration at MECO – Mahape Work and Performance of MECO Make Power & Harmonics Analyser Model PHA- 5850 – B.
Ref.: Purchase Order No. MGL/C&P/4500001382/10-11/BB Dated 26 June 2011 for Supply of Three Phase Power Quality Analyzer (MECO-Power & Harmonics Analyser, PHA-5850B)

We thank Mr. Haren Shah-Marketing Executive for imparting Satisfactory Training and Demonstration to all our following Engineers who were present at your work on 14th October 2011. Our Engineer team member were also satisfied with the interaction and question / answer session.

Name:	Designation	Name:	Designation
Ms. Dipiti Lohchab	Executive	Mr. Manish Gupta	Asst. Manager
Mr. Vinkal Kotangale	Executive	Mr. Mahesh Kolte	Asst. Manager
Mr. Manas Khaire	Asst. Manager	Mr. Ganesh Patil	Asst. Manager
Mr. Vaibhav Pagnis	Asst. Manager	Mr. Pramod Kamble	Asst. Manager
Mr. Bhushan Kamble	Asst. Manager	Mr. Suhas Mandh	Sr.Asst.
Mr. Abhinav Nigam	Asst. Manager	Mr. Mahesh Kolte	Sr.Asst.
Mr. Manish Gupta	Asst. Manager		

We are pleased to inform you that MECO Make Power & Harmonics Analyser Model PHA- 5850B Kit supplied to us against above purchase order is working satisfactory. Purpose of purchasing the same instruments gives us satisfactory results as per our requirements and application.

We look forward in future to have similar technical support as and when require.

Thanking You,
For Mahanagar Gas Limited.

Pratap Ayarekar
Manager – O & M

Regd. Office : MGL House, Block No. G - 33, Bandra Kuria Complex, Opp. ICICI Tower, Bandra (E), Mumbai - 400 051. Tel. : 6678 5000



28 NOV 2013

TO WHOMSO EVER IT MAY CONCERNED

We have purchased the Power and Harmonic Analyzer model PHA 5850 from Mecco Instruments Pvt Ltd, Mumbai and the performance of the instrument during the energy audit was found to be excellent. I also appreciate the excellent service support provided by Mr Haren Shah during the last 2 years in formulating the Energy Audit reports and also software support in case of an emergency at the field.

I find the Analyzer PHA 5850 is a very cost effective and an efficient Electrical tool and is essential for an Energy auditor.

For Tata Global Beverages Ltd

Radhakrishnan Nair R
(Sr Manager- Engineering and Establishments)

Date 22.11.2013

TATA GLOBAL BEVERAGES LIMITED

Kirloskar Business Park Block C 3rd & 4th Floor Hebbal Bengaluru 560 024
Tel 91 80 67171200 Fax 91 80 67171201
Registered Office: 1 Bishop Lefroy Road Kolkata 700 020



ASIA INDIA
Pune Manufacturing Facility

2 AUG 2012

AAI India Manufacturing Corporation Pvt. Ltd.

To,
Director,
M/s. Mecco Instruments Pvt. Ltd.
Plot No. 1, MIDC Electronic Zone,
TTC Industrial Area, Mahape, Navi Mumbai – 400 710
Tel. No. 022 – 27673300 Fax No. 022 – 27673310

Dear Sir,

Sub Training and Live Demonstration of MECO Make Power & Harmonics Analyser Model PHA- 5850 at AAM Pune Manufacturing Facility, MIDC Supa Unit, Ahmednagar.

Ref Our Purchase Order No. 2636 Dated 8-June-2012 for Supply of MECO Make Power & Harmonics Analyser, Model PHA5850-B) to M/s. International Electricals, Ahmednagar.

We thanks Mr. Haren Shah-Marketing Executive, Mecco Instruments Pvt. Ltd. Navi Mumbai and Mr. Rajendra Bora – M/s. International Electricals, Ahmednagar who visited our Supa Unit on 10/07/2012 for above subject matter.

Mr. Haren Shah had given proper Training of usage of MECO Make Power & Harmonics Analyser, Model PHA5850 - B on Live Load as well as explained other features like Recording of Data, Connectivity with Laptop, Downloading data on Laptop, Analyzing and printing option etc. to the following persons presents during training.

Name	Designation	Contact No.	Email
Mr. Manoj Devi	Associate Manager-Maintenance	09860190091	manoj.devi@aam.com
Mr. Mahesh Changa	Associate Engineer-Maintenance	08600993051	mahesh.changl@aam.com

We are also satisfied with interaction and question / answer session during the training and demonstration.

We are please to inform you that MECO Make Power & Harmonics Analyser Model PHA- 5850B Kit supplied to us against above purchase order will be useful for Acquiring power data on Live Load at various site – location, Analyzing presence of Harmonics on Systems, Generating Reports, Graphs etc.

We look forward in future to have similar technical support as and when require from Mr. Haren Shah.

Thanking You,
Your Faithfully,
For AAM India Manufacturing Corporation Pvt. Ltd.

Sd/-

Manoj Devi – Associate Manager - Maintenance

c.c. For Information.

- 1) Mr. Rajendra Bora – M/s. International Electricals, Ahmednagar.
- 2) Mr. Haren Shah – Marketing Executive, M/s. Mecco Instruments Pvt. Ltd. Mahape, Navi Mumbai, Mobile No. 09820093232 Tel. No. 022 – 27673328 Fax No. 022 – 27673310 Email : haren@mecoinst.com & harenvshah@yahoo.com

Registered & Works Address: Gat No. 787 & 788, Village Hunga, Taluka Pamer, Ahmednagar-414301 State-Maharashtra
Tel. : +91 2488-243190 Fax : +91 20 30551786
www.aam.com

10 AUG 2013

सुरधनी : 25331211
.25331590



ठाणे महानगरपालिका

महानगरपालिका भवन, कै. जे. टी. एल., अहमदा वकील मार्ग, चंदनवाडी, पांचपाखाडी, ठाणे ४०० ६०२.

THE MUNICIPAL CORPORATION OF THE CITY OF THANE

संदर्भ क्र./ठा.म.पा./
Ref./T.M.C./

दिनांक : 29/07/2013
Date : 29/07/2013

To,

M/s. MECO INSTRUMENTS PRIVATE LTD.,
NAVI MUMBAI.

Sub:- Demonstration and training of Energy Auditor/Electric appliances tester (EAT-MFM-96UMT) and Power & Harmonic analyzer (PHA 5850)

Dear Sir,

With respect to above subject your marketing executive Mr.Haren Shah visited our organization (Chhatrapati Shivaji Maharaj Hospital and Rajiv Gandhi Medical Collage, Kalwa) on Dated 04/07/2013. He gave us proper and satisfactory demonstration and training of Energy auditor/Electric appliances tester (EAT-MFM-96UMT) and Power & Harmonic analyzer (PHA5850)

Thanking you,

Yours faithfully

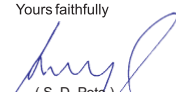
(S. D. Pote)
Dy.City Engineer (Elect.)
Thane Municipal Corporation,
Thane



MECO supports Bureau of Energy Efficiency (BEE), Govt. of India's mission to institutionalize certification of Electric / Electronic goods for ECOMARK under Gazette of India



PHA 5850



Under BEE's PAT Scheme (Perform, Achieves & Trade) it is mandated to compulsorily improve their Energy Efficiency by adopting all the available measures including replacement of their old Equipments with New and Energy Efficient Equipments

Versatile Handy instrument using micro controller technology and easy to use software program for recording and downloading.

Useful for time to time monitoring of Power Parameters, Energy and Presence of Harmonics at several Location / Machines.

Cost Effective & Efficient Tool for Energy Auditor, Maintenance Persons, Service Providers, Site / Plant Engineers.

MECO Power and Harmonics Analyser Model PHA-5850 can Analyze, Measure, Monitor & Data Log values of Power Quality & Consumption (Energy). Capable of analyzing IT standby power consumption to the maximum demand of factory. It comes with a user friendly application software that increases the utility & performance of this instrument. The analyzer is ideal for an any Engineer / Inspector for carrying out Periodic Visits, Maintenance of Plant, Vigilance checks, Surveys and Energy Audits for checking at Industrial and Consumers end.

Features:

- Analysis of 3P4W, 3P3W, 1P2W, 1P3W Systems
- Display of 35 Parameters in one screen (3P4W)
- Programmable CT (1 to 600) and PT (1 to 3000) Ratios
- Graphic Phasor Diagram
- RMS, PEAK Value & Crest Factor
- True RMS value, Active Power, Apparent & Reactive Power (KVA, KVAR)
- Power Factor, Phase Angle (Φ) & Energy (WH, KWH, KVARH, PFH)
- Average / Maximum Demand (KW, MW, KVA, MVA) with Programmable Period
- Display of 50 Harmonics in one Screen with Wave form with Peak value (1024 Sample / Period)
- Analysis of total Harmonic Distortion (THD-F)
- Capture 28 Transient Events with Programmable Threshold (%) (DIP, SWELL & OUTAGE)
- Built in timer & Calender for Data Logging
- Facility to retrieve Power Data & Harmonics on Meter Screen
- 512K Memory with Programmable Interval (2 to 3000 seconds, 17000 records for 3P4W System)
- Optical Isolated RS-232C ~ USB Interface
- Software for easy download of Recorded Data & Transient events
- Calculated Unbalanced Current through Neutral line

General Specification : PHA5850

Battery Type	1.5V SUM-3 x 8	Operating Condition	-10°C to 50°C ≤ 85% RH
External DC Input	Power supply adapter 12 Volts. DC	Storage Condition	-20°C to 60°C ≤ 75% RH
Display	Dot Matrix LCD (240x128) with backlight	Dimension	257 x 155 x 57 mm
LCD Update Rate	1 time / second	Weight	1160 g (Batteries included)
Power Consumption	140mA (approx.)	Accessories	Voltage Test Leads x 4 (3 meter long)
No. Of Samples	1024 samples / period		Alligator Clips (Voltage) x 4 (R.Y.B.N.)
Data Logging Files	85		Carrying Bag x 1
Max. File Capacity	17474 records (3P4W, 3P3W)		Batteries 1.5V DC x 8
	26210 records (1P3W)		External DC Adaptor x 1
	52420 records (1P2W)		Software CD x 1
	4096 records (50 Harmonics / record)		Users Manual x 1
Sampling Time	2 to 3000 seconds for data logging		Software Manual x 1
Low battery Indication	<input type="checkbox"/> B <input type="checkbox"/>		Optical USB Cable x 1
Overload Indication	OL		Current Clamps x 3 (Any One CT Set)

Specifications : (23°C ± 5°C)

AC Current

(50Hz or 60Hz, Auto Range, True RMS, Crest Factor < 4, CT = 1)

Model : PHA-5850A (100A) (Overload Protection AC 200A)

Range	Resolution	Accuracy of Readings
0.04 - 1A	1mA	±0.5% ±0.05A
0.4 - 10A	0.01A	±0.5% ±0.05A
4 - 100A	0.1A	±1.0% ±0.5A

Model : PHA-5850B (1000A) (Overload Protection AC 2000A)

Range	Resolution	Accuracy of Readings
10.00A	0.001A / 0.01A	-
5A - 100.0A	0.01A / 0.1A	±0.5% ±0.5A
40A - 1000.0A	0.1A / 1A	±0.5% ±5A

Model : PHA-5850C (3000A) (Overload Protection AC 3000A)

Range	Resolution	Accuracy of Readings
10.0 - 300.0A	0.1A	±1% of range
300.0 - 3000A	0.1A / 1A	

Model : PHA-5850D (1200A) (Overload Protection AC 1200A)

Range	Resolution	Accuracy of Readings
6.0 - 120.0A	0.1A	±1% of range
120.0 - 1200A	0.1A / 1A	

Harmonic of AC Voltage in Percentage

Range	Resolution	Accuracy
1 - 20th	0.1%	±2%
21 - 49th		±4% of reading ±2.0%
50 - 99th		±6% of reading ±2.0%

Harmonic of AC Current in Percentage

Model : PHA-5850A (100A)

Range	Resolution	Accuracy
1 - 10th	0.1%	±0.2% of reading ±1%
11 - 20th		±2% of reading ±1%
21 - 50th (A range)		±5% of reading ±1%
21 - 50th (mA range)		±10% of reading ±1%
51 - 99th		±35% of reading ±1%

Model : PHA-5850B (1000A)

Range	Resolution	Accuracy
1 - 20th	0.1%	±2%
21 - 49th		±4% of reading ±2.0%
50 - 99th		±6% of reading ±2.0%

Model : PHA-5850C (3000A) & PHA-5850D (1200A)

Range	Resolution	Accuracy
1 - 20th	0.1%	±2%
21 - 50th		±6%
51 - 99th		±10%

AC Watt

(50Hz or 60Hz, PF 0.5 ~ 1, CT = 1, continuous waveform)

Model : PHA-5850A (100A)

Range (0 to 100A)	Resolution	Accuracy of Readings
5.0 - 999.9W	0.1W	±1% ±0.8W
1.000 - 9.999KW	0.001KW	±1% ±8W
10.00 - 99.99KW	0.01KW	±1% ±80W
100.0 - 999.9KW	0.1KW	±1% ±0.8KW
1000 - 9999KW	1KW	±1% ±8KW

Model : PHA-5850B (1000A)

Range (0 to 1000A)	Resolution	Accuracy of Readings
5.0 - 999.9W	0.1W	±1% ±0.8W
1.000 - 9.999KW	0.001KW	±1% ±8W
10.00 - 99.99KW	0.01KW	±1% ±80W
100.0 - 999.9KW	0.1KW	±1% ±0.8KW
1000 - 9999KW	1KW	±1% ±8KW
0.000 - 9.999MW	0.001MW	±1% ±80KW

Model : PHA-5850C (3000A)

Model : PHA-5850D (1200A)

Range (0 to 3000A or 0 to 1200A)	Resolution	Accuracy of Readings	
		> 20V & > 30A	< 20V or < 30A
10.0 - 999.9W	0.1W	±1% of range	±2% of range
1.000 - 9.999KW	0.001KW		
10.00 - 99.99KW	0.01KW		
100.0 - 999.9KW	0.1KW		
1000 - 9999KW	1KW		

AC Voltage

(50Hz or 60Hz, Auto Range, True RMS, Crest Factor < 4, Input Impedance 10MΩ, VT (PT) = 1, Overload Protection AC 800V)

Range	Resolution	Accuracy of Readings
20.0V - 500.0V (Phase to Neutral)	0.1V	±0.5% ±5dpts
20.0V - 600.0V (Phase to Phase)		

Power Factor (PF)

Model : PHA-5850A (100A) & PHA-5850B (1000A)

Range	Resolution	Accuracy
0.00 - 1.00	0.01	±0.04

Model : PHA-5850C (3000A) & PHA-5850D (1200A)

Range	Resolution	Accuracy	
		> 20V & > 30A	< 20V or < 30A
0.000 - 1.000	0.001	±0.04	±0.1

Data Logging on Meter & PC



Data Retrieval for Energy Study & Audit



Ordering Information

Model : PHA 5850A = PHA 5850 + CT set A
Model : PHA 5850B = PHA 5850 + CT set B

Model : PHA 5850C = PHA 5850 + CT set C
Model : PHA 5850D = PHA 5850 + CT set D



Model : CT set A

3 pcs (R,Y,B) Clamp - On CTs
Conductor Size : 30mm (approx.)
Range : 1 / 10 / 100A



OR

Model : CT set B

3 pcs (R,Y,B) Clamp - On CTs
Conductor Size : 55mm (approx.) Busbar 64 x 24mm
Range : 10 / 100 / 1000A



OR

Model : CT set C

3 pcs Flexible CTs
Probe Length : 24" / 610mm (approx.)
Minimum bending Diameter : 35mm
Conector Diameter : 23mm
Cable Diameter : 14mm
Cable Length from Probe to Box : 1700mm
Cable Length from Box to Output : 1700mm
Range : 300 / 3000A



OR

Model : CT set D

3 pcs Flexible CTs
Probe Length : 18" / 460mm (approx.)
Minimum bending Diameter : 35mm
Conector Diameter : 23mm
Cable Diameter : 14mm
Cable Length from Probe to Box : 1700mm
Cable Length from Box to Output : 1700mm
Range : 120 / 1200A





MECO supports Bureau of Energy Efficiency (BEE), Govt. of India's mission to institutionalize certification of Electric/Electronic goods for ECOMARK under Gazette of India



EAT-MFM-96UMT

Accessories

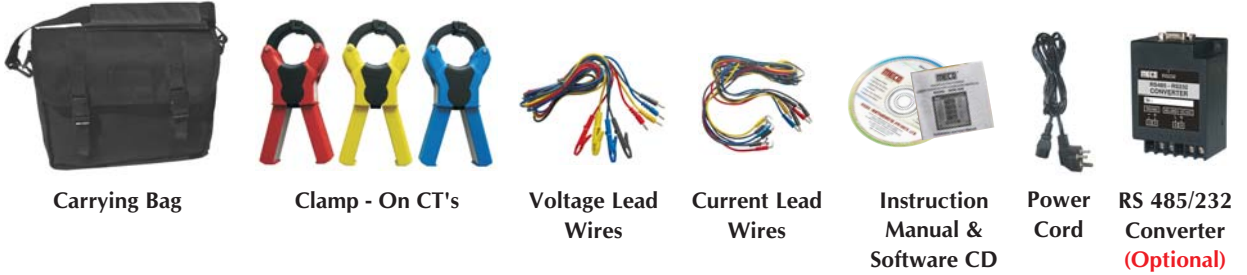

Features

- 12 Parameters, 68 Values on 22 Pages
- 3 Phase 4 Wire
- Complete with Standard Accessories
- Programmable CTR, PTR, Instr. Address, Password & MD Period
- Coloured Input Terminals for Phase Identification
- POWER MASTER Software Datalogging, Tabulation & Graphs
- Built-In 20 Energy Meters of 8 Digit Resolution
- TRMS Measurement
- Rugged & Portable Casing
- RS 485 Port, 5kV Isolated Port (Standard)
- Max. Demand, THD, Password Protection & Auto Scroll Facilities
- Energy Retention & Energy Reset Facility
- Clamp-On CT's for Current Input
- Full Annunciators on Display

Applications

- Energy Audit ● Appliance Testing ● Testing LV Power Distribution Switchboards ● QC Testing ● Studying Energy Exchange Points
- Building Management Systems ● Power Management ● Generator / Motor Characteristics ● Plant Maintenance ● Datalogging

Technical Specifications

Model	EAT-MFM-96UMT (with Triple Range CT's)	
System	3Phase 4Wire 3Element System	
Measures	V,A,W,Var,VA,HZ,PF,KWh,KVArh,KVah,MD & THD with 68 Values on 22 Display Pages	
Voltage Input	Direct Thru. PT	50 - 300V (Max.) (Phase to Neutral) PT Ratio Fully Programmable From 1.000 ~ 9999
Current Input	Direct Thru. CT	1A - 6A AC Max. (Direct) Supplied with 3 pcs Clamp-On CT's (Red, Yellow, Blue) of Triple Range ie 100, 500, 1000/5A AC. The CT Ratio Programmable on the Instrument by the User From 1.000 ~ 9999
Power Supply	230V AC \pm 20%, 50Hz (Standard), 110V AC \pm 20%, 50Hz (Optional)	
Programmable Parameters	CTR, PTR, Instrument Address, MD Period & Password	
Key Pad	4 Function Keys to Scroll through Display Pages and for Programming Parameters	
Display	Simultaneous Display of 4 Parameters, 4 Digits Resolution, 0.36" / 9.2mm Digit Height 0000 ~ 9999 Counts & 0000 0000 ~ 9999 9999 (Energy)	
Serial Communication	RS-485 Port, 5KV Isolated, MODBUS-RTU Protocol	
Software Support	POWER MASTER Software	
Other Specifications	As per MFM-96UMT & Clamp - On CT's catalog	
Input Terminals	Suitable for ϕ 4mm Jack Banana : Voltage (4) & Current (6)	
Accessories (Standard)	Complete Portable Instrument consisting MFM-96UMT, 3 pcs High Current Clamp-On CT's (R, Y, B), 4 pcs Voltage Probes (R, Y, B, Black, One Side Banana / One Side Crocodile, 2m each), 6 pcs Current Lead Wires (R, Y, B & 3 x Black, One Side Banana / One Side "U", 2m each), RS-485 Communication Port, Instruction Manual, 3 Pin Power Cord, Standard Power Master Software CD and Carrying Bag	
Accessories (Optional)	RS-485 / RS-232 Converter with AC Mains Adaptor	

Ordering Information : Model & Optionals



PLH 5760

Features

- True RMS value (V and A)
- Leakage Current Measurement at 10µA Resolution
- Harmonic Analysis (V and A) to the 99th Order
- Better Understanding of High Frequency Harmonic Analysis (up to 5/6 KHz)
- Non-interrupted Harmonic Analysis
- Analysis of Total Harmonic Distortion (%THD-F)
- Analysis of Crest Factor (C.F.)
- Fast Peak Function (33µs for 60Hz & 39µs for 50Hz)
- Programmable CT Ratio (1 to 250)
- W, KW, HP, VA, KVA, VAR, KVAR
- PF, Phase Angle (Φ)
- Energy (mWH, WH, KWH)
- Analysis of Standby Power Consumption
- Balanced 3 Phase Power Quality
- Balanced 3 Phase Sequence
- Max., Min. & Data Hold Function
- Active Power in HP

General Specifications

- Jaw Opening** : Cable Dia 30mm (approx.)
- Battery Type** : 1.5V SUM-3 x 2
- Display** : 4+2+2 digits LCD
- Auto-Power-Off** : 30 minutes
- LCD update rate** : 2 times / sec.
- Operating Temperature** : -10°C to 50°C
- Storage Temperature** : -20°C to 60°C
- Option** : Alligator clips
- Power Consumption** : 10mA (approx.)
- No. of Samples/Period** : 512 (V & A), 256 (W)
- Operating Humidity** : < 85% relative
- Storage Humidity** : < 75% relative
- Weight** : 210gms Including Battery (approx.)
- Dimension** : 210 x 72 x 36 mm
- Accessories** : Test Leads, Carry Bag, Users Manual, Batteries (installed)

Specifications (23°C ± 5°C)

Harmonics of AC Current in % & Magnitude (1 - 99th order)				
Range	Resolution in %	Accuracy in %	Resolution in Magnitude	Accuracy in Magnitude
1 - 10th	0.1 %	±0.7% of reading ± 1%	0.01mA 0.1mA 0.001A 0.01A	± 1% of reading ± 2mA ± 1% of reading ± 0.3A
11 - 20th		± 2% of reading ± 1%		± 7% of reading ± 2mA ± 7% of reading ± 0.3A
21 - 50th (A range)		± 5% of reading ± 1%		± 15% of reading ± 0.3A
21 - 50th (mA range)		± 10% of reading ± 1%		± 15% of reading ± 3mA
51 - 99th		± 35% of reading ± 1%		± 35% of reading ± 3mA ± 35% of reading ± 0.3A

Harmonics of AC Voltage in % & Magnitude (1 - 99th order)				
Range	Resolution in %	Accuracy in %	Resolution in Magnitude	Accuracy in Magnitude
1 - 10th	0.1 %	±0.7% of reading ± 1%	0.1V	±0.7% of reading ± 7 dgts
11 - 20th		± 2% of reading ± 1%		± 2% of reading ± 7 dgts
21 - 50th		± 5% of reading ± 1%		± 5% of reading ± 7 dgts
51 - 99th		± 35% of reading ± 1%		± 35% of reading ± 7 dgts
				± 35% of reading ± 7 dgts

AC Watt (50 or 60Hz, PF 0.6 to 1. CT = 1, Accuracy of Readings)			
Range	Resolution	Accuracy (0 - 60A)	Accuracy (60 - 100A)
0.050 - 9.999W	0.001W	± 2% ± 0.025W	± 2% of VA ± 5 dgts
10.00 - 99.99W	0.01W	± 2% ± 0.25W	
100.0 - 999.9W	0.1W	± 2% ± 2.5W	
1.000 - 9.999KW	0.001KW	± 2% ± 0.025KW	
10.00 - 99.99KW	0.01KW	± 2% ± 0.25KW	
100.0 - 999.9KW	0.1KW	± 2% ± 2.5KW	
1000 - 9999KW	1KW	± 2% ± 25KW	

AC Current (50 or 60Hz, True RMS)		
Range	Resolution	Accuracy
00.50 - 60.00mA	0.01mA	± 0.5% ± 5 dgts
60.00 - 100.0mA	0.01/0.1mA	± 0.5% ± 50 dgts
100.0 - 600.0mA	0.1mA	± 0.5% ± 5 dgts
0.050 - 3.000A	0.001A	
3.000 - 30.00A	0.001/0.01A	
30.00 - 90.00A	0.01A	± 1.0% ± 5 dgts

AC Voltage (50 or 60Hz, True RMS)		
Range	Resolution	Accuracy
5 - 250V	0.1 V	± 0.5% ± 5 dgt
250 - 600V		

Power Factor & Phase Angle		
Range	Resolution	Accuracy
0.000 - 1.000	0.001	± 0.04
-180° to 180° & 0° to 360°	0.1°	± 2°

Total Harmonic Distortion (THD-F, 1 - 50th order)		
Range	Resolution	Accuracy
0.0 - 20.0%	0.1%	± 2%
20.0 - 100%	0.1%	± 3% of reading ± 5%
100 - 999.9%	0.1%	± 10% of reading ± 10%

Crest Factor (C.F., Accuracy of Readings)		
Range	Resolution	Accuracy
1.00 - 99.99	0.01	± 5% ± 30 dgt



PHT 4545

Power Analysis

- W, KW, HP, VA, KVA, VAR, KVAR ● PF, Phase Angle (Φ) ● Energy (WH, KWH)
- Balanced 3Phase Power Quality ● Balanced 3Phase Sequence ● Programmable CT Ratio (1 to 250) ● Dual Displays (W+PF, VA+KVAR...) ● Active Power in HP
- Resistance and Continuity with Beeper

Harmonic Analysis

- True RMS value (V and A) at 0.5% basic accuracy ● 1500A AC ● Harmonic Analysis (V and A) to the 99th Order in % and in magnitude ● Better Understanding of High Frequency Harmonic Analysis (up to 5/6 KHz) ● Non-interrupted Harmonic Analysis ● Analysis of Total Harmonic Distortion (%THD-F) ● Analysis of Crest Factor (C.F.) ● Fast Peak Function (33μs for 60Hz and 39μs for 50Hz)
- Max, Min and Data Hold Function

General Specifications

- Jaw Opening** : Cable Dia 55mm (approx.), 64 x 24mm (Bus Bar)
- Battery Type** : 1.5V SUM-3 x 2
- Display** : 4 + 4 digits LCD
- Auto-Power-Off** : 30 minutes
- LCD update rate** : 2 times / sec.
- Operating Temperature** : -10°C to 50°C
- Storage Temperature** : -20°C to 60°C
- Option** : alligator clips
- Power Consumption** : 10mA (approx.)
- No. of Samples/Period** : 512 (V & A), 256 (W)
- Operating Humidity** : < 85% relative
- Storage Humidity** : < 75% relative
- Weight** : 650gms Including Battery (approx.)
- Dimension** : 271 x 112 x 46 mm
- Accessories** : Test Leads, Carry Bag, Users Manual, Batteries (installed)

Specifications (23°C ± 5°C)

Harmonics of AC Current in % & Magnitude (1 - 99th order)				
Range	Resolution in %	Accuracy in %	Resolution in Magnitude	Accuracy in Magnitude
1 - 20th	0.1%	±2%	0.1A	±2% of reading ± 0.4A
21 - 49th		4% of reading ± 2.0%		±4% of reading ± 0.4A
50 - 99th		6% of reading ± 2.0%		±6% of reading ± 0.4A

Harmonics of AC Voltage in % & Magnitude				
Range	Resolution in %	Accuracy in %	Resolution in Magnitude	Accuracy in Magnitude
1 - 20th	0.1%	±2%	0.1V	±2% ± 0.5V
21 - 49th		4% of reading ± 2.0%		±4% of reading ± 0.5V
50 - 99th		6% of reading ± 2.0%		±6% of reading ± 0.5V

Crest Factor (C.F., Accuracy of Readings)		
Range	Resolution	Accuracy
1.00 - 99.99	0.01	± 5% ± 30 dgt

AC Watt (50 or 60Hz)		
Range	Resolution	Accuracy
10.0 - 999.9W	0.1W	±2% ± 20 dgt (> 20V & > 20A)
1.000 - 9.999KW	0.001KW	
10.00 - 99.99KW	0.01KW	
100.0 - 999.9KW	0.1KW	±2% ± 40 dgt
1000 - 9999KW	1KW	(< 20V or < 20A)

AC Current (50 or 60Hz, True RMS)		
Range	Resolution	Accuracy
10.0 to 1500.0A	0.1A	±2% ± 5 dgt

AC Voltage (50 or 60Hz, True RMS)		
Range	Resolution	Accuracy
10.0 to 600.0V	0.1V	±0.5% ± 5 dgt

Power Factor & Phase Angle		
Range	Resolution	Accuracy
0.000 - 1.000	0.001	±0.04
-180° to 180° & 0° to 360°	0.1°	± 2°

Total Harmonic Distortion (THD-F, 1 to 50th order)		
Range	Resolution	Accuracy
0.0 - 20%	0.1%	±2%
20 - 100%		±6% of reading ± 1%
100 - 999.9%		±10% of reading ± 1%

Resistance (Ω) and Continuity (Beep if less than 50Ω)		
Range	Resolution	Accuracy
* 7.0 - 999.9Ω	0.1Ω	± 5Ω
1000 - 1200Ω	1Ω	

* If reading is less than 7Ω, it is displayed as 0Ω



4500

Electrical Specification (23°C ± 5°C)

AC + DC True Power (PF 0.2 ~ 1.0, 3φ3W, 3φ4W, 1φ2W, and 1φ3W)			
Range	Resolution	Accuracy (of rdg)	Range
0 ~ 99.99KW	0.01KW	± 2.0% ± 0.05KW	AC 600V, DC 600V, ACA/DCA 2000A
100 ~ 999.9KW	0.1KW	± 2.0% ± 0.5KW	AC 600V, DC 600V, ACA/DCA 2000A
1000 ~ 1200KW	1KW	± 2.0% ± 5KW	AC 600V, DC 600V, ACA/DCA 2000A

AC + DC True Power (Power Factor 0.2 ~ 1.0, 3φ Balanced Power)			
Range	Resolution	Accuracy (of rdg)	Range
0 ~ 99.99KW	0.01KW	± 2.0% ± 0.5KW	AC 600V, DC 600V, ACA/DCA 2000A
100 ~ 999.9KW	0.1KW	± 2.0% ± 0.5KW	AC 600V, DC 600V, ACA/DCA 2000A
1000 ~ 2000KW	1KW	± 2.0% ± 5KW	AC 600V, DC 600V, ACA/DCA 2000A

AC + DC Voltage (True RMS, Crest Factor < 4, Autorange, Overload Protection 800VAC for all range)				
Range	Resolution	Accuracy (of reading)		Input Impedance
		DC, 50/60 Hz	40-400 Hz	
0 ~ 200V	0.1V	± 1.5% ± 5 dgt	± 2.0% ± 5 dgt	10MΩ
200 ~ 500V	0.1V	± 1.5% ± 5 dgt	± 2.0% ± 5 dgt	10MΩ
500 ~ 600V	1V	± 1.5% ± 5 dgt	± 2.0% ± 5 dgt	10MΩ

AC + DC Current (True RMS, Crest Factor < 4)				
Range	Resolution	Accuracy (of reading)		Overload Protection
		DC, 50/60 Hz	40-400 Hz	
0 ~ 200A	0.1A	± 1.5% ± 5 dgt	± 2.0% ± 5 dgt	AC 3000A
200 ~ 500A	0.1A	± 2.0% ± 5 dgt	± 2.5% ± 5 dgt	AC 3000A
500 ~ 2000A	1A	± 2.5% ± 5 dgt	± 3.0% ± 5 dgt	AC 3000A

How one wished, one could measure 3φ power with a single clamp meter without any manual calculations; well now it is a reality. MECO 4500 Clamp-On Power Meter does this with absolute ease and reliability. Be it 3φ4W, 3φ3W, balanced or unbalanced system. Needless to add, it also works for 1φ2W and 1φ3W systems. Handy and ideal for on-site measurement, energy audit, data recording, Q.C. testing and maintenance of the entire plant.

Features

- 3φ4 W, 3φ3 W, 3φ Balanced, 1φ2 W, 1φ3 W
- AC + DC 2000 KW (3φ), 1200 KW (1φ)
- Dual display KW + PF, KVA + KVAR, V + A, V + Hz, A + Hz
- Phase Angle Measurement (± 90°), Phase Sequence Indication (R,S,T)
- AC 600V, DC 600V, AC + DC 2000A
- Power Factor
- AC/DC Auto Detection
- TRMS Values
- Memory of 4 records
- Auto Range

KVA + KVAR



V + Hz



Power Factor (PF)

$$PF = \frac{KW}{KVA}$$

AC + DC KVA (Apparent Power)

$$KVA = \frac{V \times A}{1000}$$

AC + DC KVAR (Reactive Power)

$$KVAR = \sqrt{(KVA)^2 - (KW)^2}$$

General Specifications

Jaw Opening

Cable Dia. 55mm. (approx.)
Bus Bar 65 (D) x 24 (W) mm

Battery Type

9V, Eveready type 216 or eq.

Display

2x4 Digits Dual Display LCD

Range Selection

Auto

Overload Indication

OL

Power Consumption

25mA (approx.)

Low Battery Indication

B

Sampling Time

0.5 sec. (V and A)
1.6 sec. (W)

Operating Temp.

4° to 50°C

Operating Humidity

< 85% RH

Storage Temperature

-20°C to 60°C

Storage Humidity

< 75% RH

Dimensions

271 x 112 x 46 mm

Weight

650gms Battery Including (approx.)

Accessories

- Carry Bag x 1,
- Users Manual x 1,
- Battery (Installed) x 1,
- Test Lead x 1 Pair
- Crocodile Test Lead x 1 Pair

Phase Angle (Must zero the current reading before measurement)			
Range	Accuracy	Sensitivity	Remark
-90° to +90° (50/60 Hz)	± 2.0°	V > 100V, A > 10A	Zero Crossing Detection

* If current signal is not detected, the phase angle will be left blank in LCD.

Frequency (if < 10 Hz, Hz = 0)		
Range	Accuracy	Sensitivity
50/60 Hz	± 2dgts	V > 1V, A > 5A
10-400 Hz	± 0.5% ± 2dgt	V > 1V, A > 5A



Bus-Bar upto
16mm x 65mm
Cable upto
43mm Diameter

3510PHE-AUTO

Features

- TRMS Measurement
- KW, KVAR, KVA, HP & Energy Measurement
- PF & Phase Angle (Φ) Measurement
- 4 Digit LCD, 9999 Count, Autoranging
- Data Hold, Auto Power Off
- Cable of Diameter upto 43mm / Busbar upto 65mm x 16mm

Applications

- Check Motors and Compressors
- Check for Energized Circuits & Loads
- Ideal for Electrical Energy Audit of Heating, Ventilation & Aircon Systems (HVAC)
- To Identify Low Voltage Control Signal
- To Identify Power Sources
- 1 ϕ / 3 ϕ (3p3w/3p4w) Power Calculations
- Evaluate Electrical Contacts
- Verify the Stability of Voltage

1 ϕ / 3 ϕ TRUE Power : (PF > 0.5 or θ < 60°) (1HP = 0.7457KW)			
Range	Resolution	Accuracy \pm (%rdg + dgts)	Overload Protection
99.99KW	0.01KW	\pm (5% + 30)	600VAC/
600.0KW	0.1KW	(50, 60Hz)	1000AAC

1 ϕ / 3 ϕ HP (1HP = 745.7W) : (PF > 0.5 or θ < 60°)			
Range	Resolution	Accuracy \pm (%rdg + dgts)	Overload Protection
99.99HP	0.01HP	\pm (5% + 30)	600VAC/
800.0HP	0.1HP	(50, 60Hz)	1000AAC

1 ϕ / 3 ϕ Apparent Power			
Range	Resolution	Accuracy \pm (%rdg + dgts)	Overload Protection
99.99KVA	0.01KVA	\pm (2.5% + 30)	600VAC/
600.0KVA	0.1KVA		1000AAC

1 ϕ / 3 ϕ Reactive Power : (PF > 0.5 or θ < 60°)			
Range	Resolution	Accuracy \pm (%rdg + dgts)	Overload Protection
99.99KVAR	0.01KVAR	\pm (5% + 30dgts)	600V AC/
600.0KVAR	0.1KVAR	(50, 60Hz)	1000A AC

1 ϕ / 3 ϕ PF & Phase Angle (50Hz, 60Hz)			
Range	Resolution	Accuracy	Sensitivity
-60°/0°/+60° -0.5/1/+0.5	0.1°	\pm 6.0°	ACV > 100V, ACA > 10A

Energy			
Range	Resolution	Accuracy	Overload Protection
KWh	0.1	\pm (5% + 30) (50, 60Hz)	600V AC / 1000A AC
KVARh			
KVAh			

Frequency			
Range	Resolution	Accuracy \pm (%rdg + dgts)	Sensitivity
40/400Hz	0.1Hz	\pm (0.5% + 2)	ACV > 1.2V, ACA > 6A

AC Current (50Hz to 400Hz) : TRMS				
Range	Resolution	Accuracy \pm (%rdg + dgts)	Sensitivity	Overload Protection
99.99A	0.01A	\pm (2% + 30) (50,60Hz)	0.10A	1000A
999.9A	0.1A	\pm (4% + 30) (40-400Hz)	1.0A	

AC Voltage (50Hz to 400Hz) : TRMS				
Range	Resolution	Accuracy \pm (%rdg + dgts)	Sensitivity	Overload Protection
9.999V	0.001V	\pm (1% + 30) (50,60Hz) \pm (2% + 30) (40-400Hz)	0.020V	600V
99.99V	0.01V		0.20V	
600.0V	0.1V		2V	
Input Impedance : 3M Ω				

DC Voltage				
Range	Resolution	Accuracy \pm (%rdg + dgts)	Sensitivity	Overload Protection
9.999V	0.001V	\pm (1% + 30)	0.020V	600V
99.99V	0.01V		0.20V	
600.0V	0.1V		2V	
Input Impedance : 3M Ω				

General Specifications

Numerical Dual Display : 4 Digit 9999 Count LCD
Low Battery Indication :  is displayed
Power Source : 9V Battery x 1
Battery Life : 32 hours approx.
Sampling Rate : 2.5 times/sec. (Digital Display)
 1 times/6 sec. (on KW, KVA)
Dimensions : 247 x 90 x 40mm (approx.)
Weight : 425gms Including Battery (approx.)
Jaw Opening : Cable Dia 43mm (max.)
 Bus Bar 16mm x 65mm

Auto Power off Time : Approx. 15 minutes
Operating Temperature and Humidity : 0°C to 50°C (32°F to 122°F)
 RH < 80% non-condensing
Storage Temperature and Humidity : -10°C to 60°C (14°F to 140°F)
 RH < 70% non-condensing
Temperature Coefficient : 0.1 x (specified accuracy)/°C
 (<18 or >28°C, <64 or >82°F)
Accessories : Carrying Case, Battery (installed),
 One Set Test Leads & Instruction Manual

Usage

1 ϕ 2W System

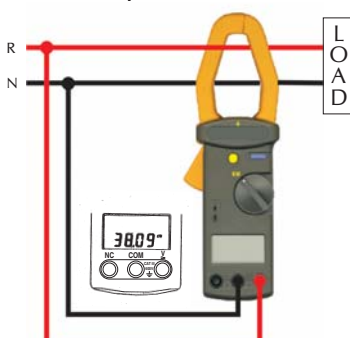

$PF = \frac{KW}{KVA} = \cos\theta$
 HP = 746 watts
 $KVA = (V \times A) / 1000$
 $KVAR = KVA \times \sin\theta$

3 ϕ 3W System

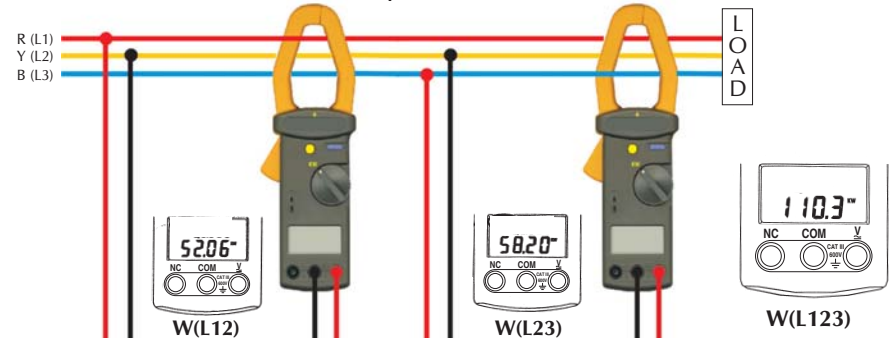

$W_{3\phi 3W} = W_{RY} (L1L2) + W_{BY} (L3L2)$
 $KVA_{3\phi 3W} = \sqrt{KW^2_{3\phi 3W} + KVAR^2_{3\phi 3W}}$
 $PF_{3\phi 3W} = \frac{KW_{3\phi 3W}}{KVA_{3\phi 3W}}$

3 ϕ 4W System

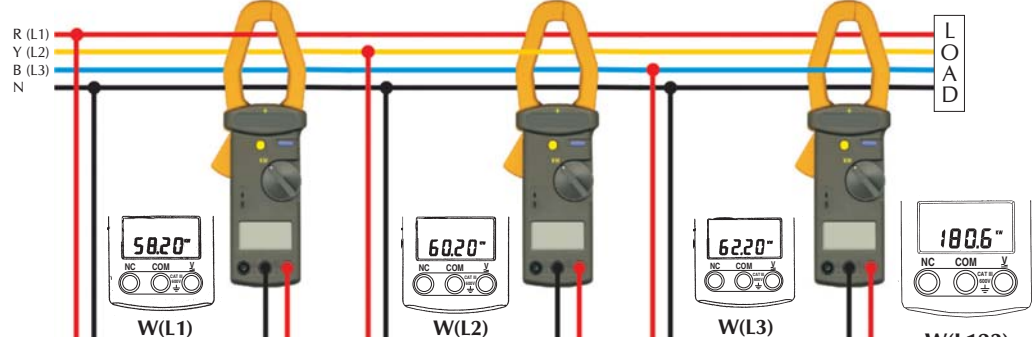

$W_{3\phi 4W} = W_R (L1) + W_Y (L2) + W_B (L3)$

$KVA_{3\phi 4W} = \sqrt{KW^2_{3\phi 4W} + KVAR^2_{3\phi 4W}}$

$PF_{3\phi 4W} = \frac{KW_{3\phi 4W}}{KVA_{3\phi 4W}}$



3510PHW-AUTO

Features

- 4 Digit LCD, 9999 Count, Autoranging
- Data Hold, Auto Power Off
- Dual Display KW + HP, KW + PF, KW + KVAR, KVA + ϕ , V + A, A + Hz, V + Hz
- Cable of Diameter upto 43mm / Busbar upto 65mm x 16mm

Applications

- Check Current drawn in Motors and Compressors
- Use MAX/MIN/REC in Temperature Mode to Assess Efficiency
- Test Run/Start Capacitors
- Analyze Temperature Data with the Aid of the Time Stamp
- Resistance upto 100M Ω
- Check for Energized Circuits & Balance Loads
- Capture Motor In-Rush Current Readings
- Determine Peak Power Demand Periods
- Ideal for Electrical Audit of Heating, Ventilation & Aircon Systems (HVAC)
- To Identify Low Voltage Control Signal
- To Identify Power Sources
- 1 ϕ & 3 ϕ (3p3w/3p4w) Power Analyzer
- Evaluate Electrical Contacts
- Verify the Stability of Voltage
- Check Motor Run / Start Capacitor Values
- Check 3 ϕ Phase Sequence

1 ϕ /3 ϕ TRUE Power : (PF > 0.5 or θ < 60°) (1hp = 0.7457KW)				
Range	Resolution	Accuracy \pm (%rdg + dgts)	Overload Protection	
99.99KW	0.01KW	\pm (5% + 30)	600VAC/	
600.0KW	0.1KW	(50, 60Hz)	1000AAC	
1 ϕ /3 ϕ HP (1HP = 745.7W) : (PF > 0.5 or θ < 60°)				
Range	Resolution	Accuracy \pm (%rdg + dgts)	Overload Protection	
99.99HP	0.01HP	\pm (5% + 30)	600VAC/	
800.0HP	0.1HP	(50, 60Hz)	1000AAC	
1 ϕ /3 ϕ Apparent Power				
Range	Resolution	Accuracy \pm (%rdg + dgts)	Overload Protection	
99.99KVA	0.01KVA	\pm (2.5% + 30)	600VAC/	
600.0KVA	0.1KVA		1000AAC	
1 ϕ & 3 ϕ Reactive Power : (PF > 0.5 or θ < 60°)				
Range	Resolution	Accuracy \pm (%rdg + dgts)	Overload Protection	
99.99KVAR	0.01KVAR	\pm (5% + 30dgts)	600V AC/	
600.0KVAR	0.1KVAR	(50, 60Hz)	1000A AC	
3 ϕ Phase Sequence Indication				
Range	Frequency Response	Overload Protection		
80V to 480V	(50Hz / 60Hz)	600V		
ACA Inrush Current				
Range	Resolution	Sensitivity	Measurement Time	Overload Protection
99.99A	0.01A	> 5A	100ms	1000A AC
999.9A	0.1A	> 50A		
1 ϕ / 3 ϕ PF & Phase Angle (50Hz, 60Hz)				
Range	Resolution	Accuracy	Sensitivity	
-60°/0°/ +60°	0.1°	\pm 6.0°	ACV > 100V, ACA > 10A	
-0.5/1/ +0.5				
Frequency				
Range	Resolution	Accuracy \pm (%rdg + dgts)	Sensitivity	
40Hz/1KHz	0.1Hz	\pm (0.5% + 2)	ACV > 1.2V, ACA > 6A	
AC Current (50Hz to 400Hz) : TRMS				
Range	Resolution	Accuracy \pm (%rdg + dgts)	Sensitivity	Overload Protection
99.99A	0.01A	\pm (2% + 30) (50,60Hz)	0.10A	1000A
999.9A	0.1A	\pm (4% + 30) (40-400Hz)	1.0A	
μ A TRMS : (AC + DC) (Burden Voltage : 5mV/ μ A) (50Hz to 400Hz)				
Range	Resolution	Accuracy \pm (%rdg + dgts)	Sensitivity	Overload Protection
99.99 μ A	0.01 μ A	\pm (1% + 30)	0.20 μ A	600V
999.9 μ A	0.1 μ A		2.0 μ A	
AC Voltage (50Hz to 400Hz) : TRMS				
Range	Resolution	Accuracy \pm (%rdg + dgts)	Sensitivity	Overload Protection
999.9mV	0.1mV	\pm (1% + 30) (50,60Hz)	2.0mV	600V
9.999V	0.001V		0.020V	
99.99V	0.01V		0.20V	
600.0V	0.1V	\pm (2% + 30) (40-400Hz)	2V	
Input Impedance : 3M Ω				
DC Voltage				
Range	Resolution	Accuracy \pm (%rdg + dgts)	Sensitivity	Overload Protection
999.9mV	0.1mV	\pm (1% + 30)	2.0mV	600V
9.999V	0.001V		0.020V	
99.99V	0.01V		0.20V	
600.0V	0.1V		2V	
Input Impedance : 3M Ω				
Resistance (Continuity < 40 Ω on the 999.9 Ω range)				
Range	Resolution	Accuracy \pm (%rdg + dgts)	Overload Protection	
999.9 Ω	0.1 Ω	\pm (1% + 10)	600V	
9.999K Ω	0.001K Ω			
99.99K Ω	0.01K Ω			
999.9K Ω	0.1K Ω			
M Ω (Auto Ranging)				
Range	Resolution	Accuracy \pm (%rdg + dgts)	Overload Protection	
9.999M Ω	0.001M Ω	\pm (5% + 10)	600V	
99.99M Ω	0.01M Ω			

Capacitance			
Range	Resolution	Accuracy \pm (%rdg + dgts)	Overload Protection
10.000 μ F	0.001 μ F	\pm (1.5% + 5)	600V
100.00 μ F	0.01 μ F		
1000.0 μ F	0.1 μ F		
7000 μ F	1 μ F	\pm (2.5% + 15)	

Diode (Continuity < 40mV)			
Range	Resolution	Accuracy \pm (%rdg + dgts)	Overload Protection
2.000V	0.001V	\pm (2% + 1)	600V

Temperature (K-Type Thermocouple)			
Range	Resolution	Accuracy \pm (%rdg + dgts)	Overload Protection
-50°C to 900°C	0.1°C	\pm (.2% + 1°C)	30VAC or 60VDC
-58°F to 1000°F	0.1°F	\pm (.2% + 2°F)	

Note : TPK-B K Type Bead Probe (Upto 260°C) Supplied with the Meter

General Specifications

- Numerical Dual Display :** 4 Digit 9999 Count LCD
- Low Battery Indication :**  is displayed
- Power Source :** 9V Battery x 1
- Battery Life :** 32 hours approx.
- Sampling Rate :** 2.5 times/sec. (Digital Display)
1 times/6 sec. (on KW, KVA)
- Operating Temperature and Humidity :** 0°C to 50°C (32°F to 122°F)
RH < 80% non-condensing
- Storage Temperature and Humidity :** -10°C to 60°C (14°F to 140°F)
RH < 70% non-condensing
- Dimensions :** 247 x 90 x 40mm
- Weight :** 425gms Including Battery (approx.)
- Jaw Opening :** Cable Dia 43mm (max.) Bus Bar 16mm x 65mm
- Accessories :** Carrying Case, Battery (installed), One Alligator Clip, Test Leads, K Type Thermocouple (Upto 260°C), Instruction Manual
- Auto Power off Time :** Approx. 30 minutes
- Temperature Coefficient :** 0.1 x (specified accuracy)/°C
(< 18 or > 28°C, < 64 or > 82°F)

Usage

1 ϕ 2W System

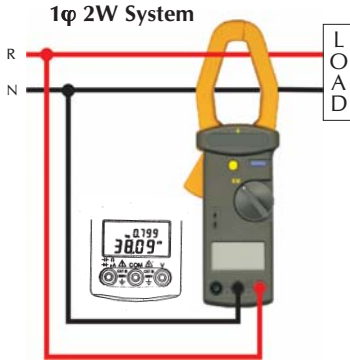

Press "RANGE" Key to Select KW + HP, KW + PF, KW + KVAR, KVA + θ or A + V

$$PF = \frac{KW}{KVA} = \cos\theta$$

$$HP = 746 \text{ watts}$$

$$KVA = (V \times A) / 1000$$

$$KVAR = KVA \times \sin\theta$$

3 ϕ 3W System

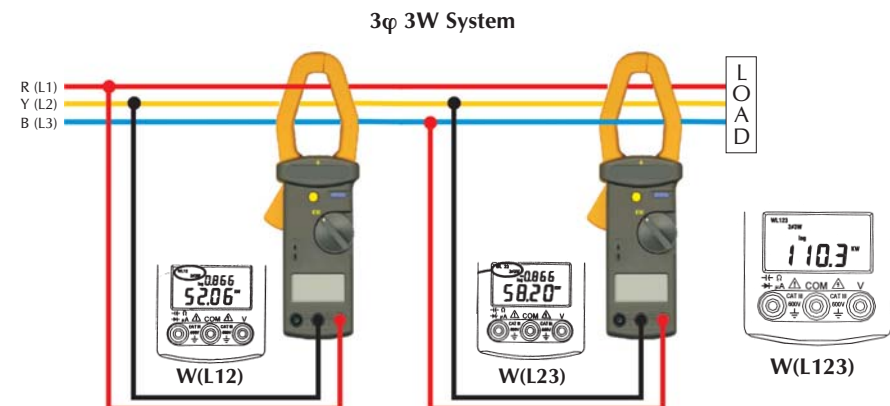

To read the details of individual data recorded, press "HOLD" key to select desired WL12, WL23 or WL123 display. Then press "RANGE" key to select KW + HP, KW + PF, KW + KVAR, KVA + θ for (L12, L23) & KVA + PF for (L123) or A + V

$$W_{3\phi 3W} = W_{RY(L1L2)} + W_{BY(L3L2)}$$

$$KVA_{3\phi 3W} = \sqrt{KW^2_{3\phi 3W} + KVAR^2_{3\phi 3W}}$$

$$PF_{3\phi 3W} = \frac{KW_{3\phi 3W}}{KVA_{3\phi 3W}}$$

3 ϕ 4W System

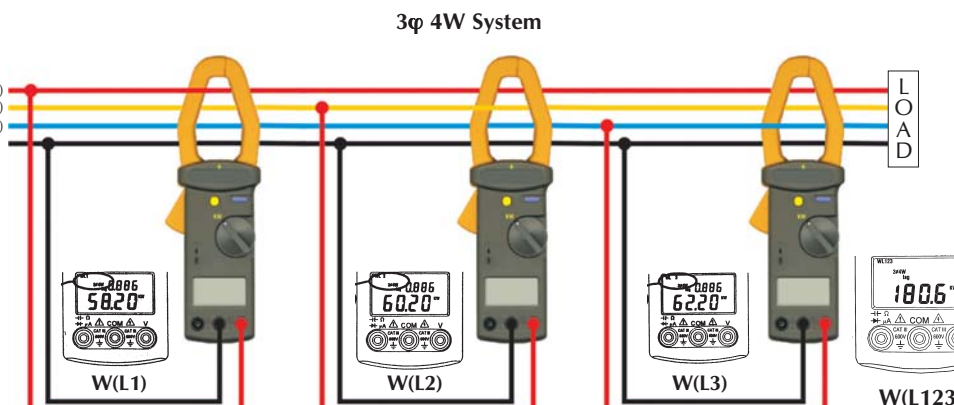

To read the details of individual data recorded, press "HOLD" key to select desired WL1, WL2, WL3 or WL123 display. Then press "RANGE" key to select KW + HP, KW + PF, KW + KVAR, KVA + θ for (L1, L2, L3) & KVA + PF for (L123) or A + V

$$W_{3\phi 4W} = W_{R(L1)} + W_{Y(L2)} + W_{B(L3)}$$

$$KVA_{3\phi 4W} = \sqrt{KW^2_{3\phi 4W} + KVAR^2_{3\phi 4W}}$$

$$PF_{3\phi 4W} = \frac{KW_{3\phi 4W}}{KVA_{3\phi 4W}}$$

3 ϕ Phase Sequence Indication

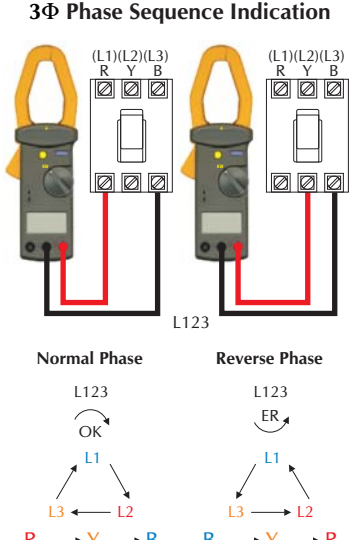

Normal Phase: L123 OK

Reverse Phase: L123 ER

R: L1, Y: L2, B: L3

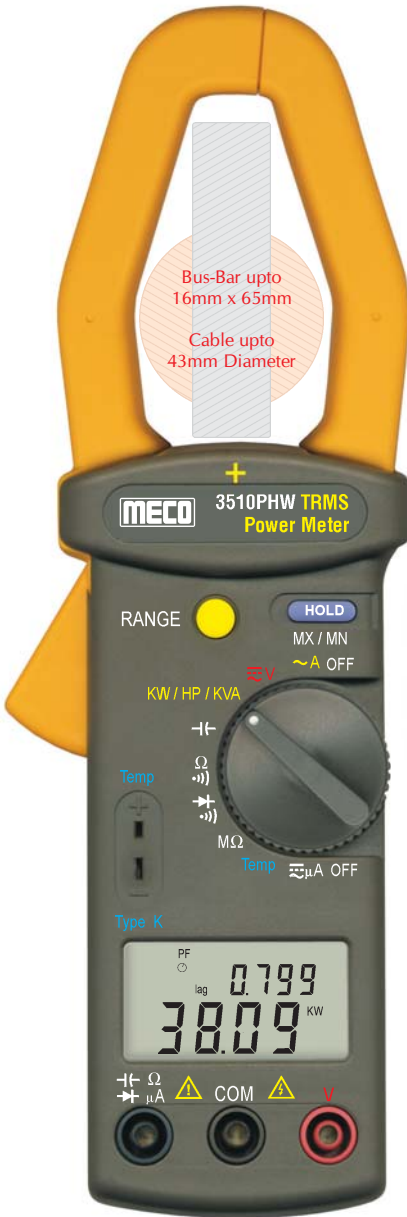

Bus-Bar upto
16mm x 65mm
Cable upto
43mm Diameter

3510PHW

Features

- 4 Digit LCD, 9999 Count, Autoranging
- Data Hold, Auto Power Off
- Dual Display KW + PF, KVA + ϕ , KW + HP, KW + KVAR, V + A, A + Hz, V + Hz
- Cable of Diameter upto 43mm / Busbar upto 65mm x 16mm
- 3 Phase Adapter

Applications

- Check Current drawn in Motors and Compressors
- Use MAX/MIN/REC in Temperature Mode to Assess Efficiency
- Test Run/Start Capacitors
- Analyze Temperature Data with the Aid of the Time Stamp
- Resistance upto 100M Ω
- Check for Energized Circuits
- Capture Motor In-Rush Current Readings
- Determine Peak Power Demand Periods
- Ideal for Electrical Audit of Heating, Ventilation & Aircon Systems

TRUE Power : (PF > 0.5 or $\theta < 60^\circ$) (1hp = 0.7457KW)			
Range	Resolution	Accuracy \pm (%rdg + dgts)	Overload Protection
60.00KW (<100A)	0.01KW	\pm (5% + 20)	600VAC/
600.0KW (>100A)	0.1KW	(50, 60Hz)	1000AAC

HP (1HP = 745.7W) : (PF > 0.5 or $\theta < 60^\circ$)			
Range	Resolution	Accuracy \pm (%rdg + dgts)	Overload Protection
80.00HP (<100A)	0.01HP	\pm (5% + 20)	600VAC/
800.0HP (>100A)	0.1HP	(50, 60Hz)	1000AAC

Apparent Power			
Range	Resolution	Accuracy \pm (%rdg + dgts)	Overload Protection
60.00KVA (<100A)	0.01KVA	\pm (2.5% + 20)	600VAC/
600.0KVA (>100A)	0.1KVA		1000AAC

PF & Phase Angle (50Hz, 60Hz)			
Range	Resolution	Accuracy	Sensitivity
-60°/0°/+60°	0.1°	\pm 3.0°	ACV > 100V, ACA > 10A
-0.5/1/+0.5			

Frequency			
Range	Resolution	Accuracy \pm (%rdg + dgts)	Sensitivity
40Hz/1KHz	0.1Hz	\pm (0.5% + 2)	ACV > 1.2V, ACA > 6A

AC Current (50Hz to 400Hz) : TRMS				
Range	Resolution	Accuracy \pm (%rdg + dgts)	Sensitivity	Overload Protection
99.99A	0.01A	\pm (2% + 20) (50,60Hz)	0.10A	1000A
999.9A	0.1A	\pm (4% + 20) (40-400Hz)	1.0A	

μ A TRMS : (AC + DC) (Burden Voltage : 5mV/ μ A) (50Hz to 400Hz)				
Range	Resolution	Accuracy \pm (%rdg + dgts)	Sensitivity	Overload Protection
99.99 μ A	0.01 μ A	\pm (1% + 20)	0.20 μ A	600V
999.9 μ A	0.1 μ A		2.0 μ A	

AC Voltage (50Hz to 400Hz) : TRMS				
Range	Resolution	Accuracy \pm (%rdg + dgts)	Sensitivity	Overload Protection
999.9mV	0.1mV	\pm (1% + 20) (50,60Hz) \pm (2% + 20) (40-100Hz)	2.0mV	600V
9.999V	0.001V	\pm (1% + 20) (50,60Hz) \pm (2% + 20) (40-400Hz)	0.020V	
99.99V	0.01V		0.20V	
600.0V	0.1V	2V		

Input Impedance : 3M Ω

DC Voltage				
Range	Resolution	Accuracy \pm (%rdg + dgts)	Sensitivity	Overload Protection
999.9mV	0.1mV	\pm (1% + 20)	2.0mV	600V
9.999V	0.001V		0.020V	
99.99V	0.01V		0.20V	
600.0V	0.1V		2V	

Input Impedance : 3M Ω

Resistance (Continuity < 40 Ω on the 999.9 Ω range)			
Range	Resolution	Accuracy \pm (%rdg + dgts)	Overload Protection
999.9 Ω	0.1 Ω	\pm (1% + 10)	600V
9.999K Ω	0.001K Ω		
99.99K Ω	0.01K Ω		
999.9K Ω	0.1K Ω		

M Ω			
Range	Resolution	Accuracy \pm (%rdg + dgts)	Overload Protection
9.999M Ω	0.001M Ω	\pm (5% + 10)	600V
99.99M Ω	0.01M Ω		

Capacitance			
Range	Resolution	Accuracy ±(%rdg + dgts)	Overload Protection
10.000μF	0.001μF	±(1.5% + 5)	600V
100.00μF	0.01μF		
1000.0μF	0.1μF		
7000μF	1μF	±(2.5% + 15)	

Diode (Continuity < 40mV)			
Range	Resolution	Accuracy ±(%rdg + dgts)	Overload Protection
2.000V	0.001V	±(2% + 1)	600V

Temperature (K-Type Thermocouple) (Thermocouple is Optional)			
Range	Resolution	Accuracy ±(%rdg + dgts)	Overload Protection
-50°C to 900°C	0.1°C	±(1% + 1°C)	30VAC or 60VDC
-58°F to 1000°F	0.1°F	±(1% + 2°F)	

General Specifications

- Numerical Dual Display** : 4 Digit 9999 Count LCD
- Low Battery Indication** : is displayed
- Power Source** : 9V Battery x 1
- Battery Life** : 32 hours approx.
- Sampling Rate** : 2.5 times/sec. (on KW, KVA, HP)
- Operating Temperature and Humidity** : 0°C to 50°C (32°F to 122°F)
RH < 80%
- Storage Temperature and Humidity** : -10°C to 60°C (14°F to 140°F)
RH < 70%
- Dimensions** : 247 x 90 x 40mm
- Weight** : 425gms Including Battery (approx.)
- Jaw Opening** : Cable Dia 43mm (max.)
Bus Bar 16mm x 65mm
- Accessories** : Carrying Case, Battery (installed),
One Pair of Alligator Clip Test Lead,
3 Phase Adapter & Instruction Manual

Usage

<p>1φ 2W System</p> <p>KW, HP, PF, φ, KVAR, KVA</p>	<p>3φ 3W Balanced System</p> <p>3φ Values = 3 x Displayed Value for KW, HP, KVAR & KVA</p>	<p>3φ 3W Unbalanced System</p> <p>Measured Value = KW1, HP1 & KVAR1</p> <p>Measured Value = KW2,a HP2 & KVAR2</p> <p>3φ Values = (KW1+KW2) or (HP1+HP2) or (KVAR1 + KVAR2)</p> <p>3φ PF = $\text{Cos}[\tan^{-1} \sqrt{3(KW1-KW2) / (KW1 + KW2)}]$</p>	
<p>3φ 4W Balanced System</p> <p>3φ Values = 3 x Displayed Value for KW, HP, KVAR & KVA</p>	<p>3φ 4W Unbalanced System</p> <p>Measured Value = KW1, HP1, KVAR1 & KVA1</p>	<p>3φ 4W Unbalanced System</p> <p>Measured Value = KW2, HP2, KVAR2 & KVA2</p>	<p>3φ 4W Unbalanced System</p> <p>Measured Value = KW3, HP3, KVAR3 & KVA3</p> <p>3φ Values = (KW1+KW2+KW3) or (HP1+HP2+HP3) or (KVAR1 + KVAR2 + KVAR3) or (KVA1 + KVA2 + KVA3)</p> <p>3φ PF = $KW_T / \sqrt{KW_T^2 + KVAR_T^2}$ or KW_T / KVA_T</p>

24 DEC 2015

☎ +91 20 32 52 82 14 / 16
+91 20 25 29 39 97
✉ +91 20 25 23 95 82
📧 info@accoladeelectronics.com
📄 www.accoladeelectronics.com

ACCOLADE[®]
 ELECTRONICS PVT. LTD.
 जेकोटेक इलेक्ट्रॉनिक्स प्रा. लि.
 An ISO 9001:2008 Company
 CNL021208P0202P7C04E037

Data Connectivity, Interface Solutions
Application Specific Medical Controllers
Embedded Systems & Solutions

To, 21st December 2015.

MECO METERS PRIVATE LTD.
Plot No. EL-60, MIDC Electronic Zone, TTC Industrial
Area, Mahape, Navi Mumbai 400710, INDIA

Subject: Customer appreciation letter.

Dear Sir,

As one of your customers, we purchased a Universal Calibrator-90P from your company. We wanted to say thank you for the assistance you gave us in purchasing the product and training to our Technical Team. We can say that we are greatly satisfied with the Universal Calibrator-90P which we bought from your company.

Again, we wanted to let you know that we greatly appreciate the effort of your company especially your personal attention & your great customer service.

Thanking you,

Deepak Jagdale
Director
Accolade Electronics Pvt. Ltd.
Pune

Reg. Office : 19-20, Fly View, Near Fly Over, Warje, Pune - 411 058 (India).
Works : Ghare Complex, S. No. 75/1, Dangat Industrial Estate, Shivne, Pune - 411 023.





Calibration & Instrument solution

- Calibration of Electro-Technical, Thermal, Mechanical & Flow Instruments / Equipment.
- Industrial Process Control Instruments, Manufacture & Repairing.

Shop No. A-31, Super Complex, Mahil Plaza, Opp. Western Fly Station, Keshavnagar, Pune-411034.
Contact No- 020-2596254.
E-mail - service.ags@gmail.com

APPRECIATION LETTER

16th-Dec-2015.

To Whomsoever It May Concern

We Have Purchased the Universal Calibrator Model No.90A From **Meco Instruments Pvt. Ltd.** Mahape Navi Mumbai. The performance of the Instrument during calibration from IDEMI Mumbai was found within claimed accuracy from Meco.

The Instrument is user friendly. We are thanking to Meco Instruments to Support us for growing our calibration Laboratories.

We hope to have similar support from your organization in future also. So it will strengthen our business relations.

For :-
Accutech Calibration & Instrument Solution.

Name: Sainath
Managing Partner



Anandha Jothi Industries

Manufacturers of Testing Equipments for Power Generation / Transmission & Distribution Systems

ISO 9001:2008 CERTIFIED UNIT

20 May 2013

To,
MECO INSTRUMENTS PRIVATE LTD.
Navi Mumbai.

Sub: Performance of MECO Multifunctional Calibrator Model 90DQ.

Ref: Purchase Order No.1080 AJI / 2010 -2011 Date: 27.12.2010.

Dear Sir/Madam,

We take pleasure in informing you that MECO Multifunctional Calibrator Model 90DQ supplied to us is working satisfactorily since the past 4 years.

We are using MECO Multifunctional Calibrator Model 90DQ for the Calibration of different type of Clamp Meters, Multi Meters & Panel Meters.

The Calibrator is found to be stable and reliable and we have pleasure in recommending the same to others.

Thank you again for your service and we will look forward to continuing our relationship in the future.

With Best Regards,
Mr. MAHENDRAN
For ANANDHA JOTHI INDUSTRIES

Proprietor
ANANDHA JOTHI INDUSTRIES, CHENNAI



No. 3/3, Viswanathan 3rd cross street, Karampakkam, Porur, Chennai - 600 116.
Mobile: +91 - 9444021461, Phone: +91 - 44 - 65272380, Tel. Fax: +91 - 44 - 2476335
www.anandhajothi.com E mail : gjiichennai@gmail.com

17 DEC 2015



SANKALP HI-TECH CORPORATION

(Calibration, Repair & Sales of Precision Measuring and Process Control Equipment)

Date: 15th DEC, 2015

To,
Meco Meters Pvt. Ltd,
Plot No. EL-60, MIDC Electronic Zone
TTC Industrial Area, Mahape,
Navi Mumbai - 400 710.
Phone : +91 22-27573310

Subject : Performance of Meco Universal Calibrator Model : 90A.

Ref: Purchase order no. 61/15-16 Dated : 25/04/2015

Dear Sir/Madam,

We take pleasure in informing you that Meco Universal Calibrator Model 90A supplied to us is working satisfactory since the past 6 months.

We are using the calibrator for Calibration of Ammeter, Voltmeter, Multimeter, Clampmeters etc.

The Calibrator is found to be stable and reliable and we have pleasure in recommending the same to others.

Thank you again for your service and we will look forward to continuing our relationship in the future.

With Best Regards,

FOR SANKALP HI-TECH CORPORATION

Proprietor



REGD. OFF. & LABORATORY :
T-3, "RAMBETH" FARMHOUSE MARGIN, DEWAS AEN TRAZAR LINK,
AMRAN-SATPUR LINK ROAD, AMRAN, MADHWA-422 016. TELEFAX : 0662-221965

MECO®

SINCE 1962

Calibrating Equipment



Reliable, Long-Lasting and Affordable Instruments ...since 1962 !

www.mecoinst.com

An ISO 9001-2008 Certified Company

MECO INSTRUMENTS PRIVATE LTD.

NAVI MUMBAI



FEATURES / PARAMETERS		90A	90DQ	90P
DISPLAY	5½ Digit Display	✓	✓	✓
SYSTEM (1 PHASE)	DC	✓	✓	-
	AC	✓	✓	✓
VOLTAGE (V)	AC/DC V : (0 - 200mV to 1000V)	✓	-	-
	AC/DC V : (0 - 250mV to 1000V)	-	✓	-
	AC V : (0 - 1V to 1000V)	-	-	✓
CURRENT (A)	AC/DC A : (0 - 100µA to 20A)	✓	-	-
	AC/DC A : (0 - 100µA to 50A)	-	✓	-
	AC A : (0 - 10mA to 100A)	-	-	✓
FREQUENCY (Hz)	SYNCH	-	✓	-
	50 Hz	✓	✓	-
	60 Hz	✓	✓	-
	400 Hz	✓	✓	-
	1 KHz	-	✓	-
	40 Hz to 70 Hz	-	-	✓
RESISTANCE	10Ω to 24k x 1kΩ	✓	✓	-
PHASE ANGLE	0 to 359.99°	-	-	✓
POWER (1 PHASE)	Range : 0 to 100kW	-	-	✓
POWER FACTOR	Range : -1 to +1	-	-	✓
COMMUNICATION PORT	RS232	✓	✓	✓
KEY ADJUSTOR		✓	✓	✓
WORKS CALIBRATION CERTIFICATE TRACEABLE TO NPL		✓	✓	✓
STANDARD CURRENT COIL (OPTIONAL)	Input 5A (Max.), Turn Ratio 100 / 1	-	✓	✓
	Input 10A (Max.), Turn Ratio 100 / 1	-	✓	✓
	Input 20A (Max.), Turn Ratio 50 / 1	✓	-	-

Applications

- R & D Labs
 - NABL Labs
 - Educational Institutes
 - Paper & Pulp Industries
- Automobile Industries
 - Textile Industries
 - Calibration Labs
 - Chemical Process Industries
- Cement Plants
 - Instrument Manufacturing Companies
 - Medical Industries
 - Petrochemical Industries

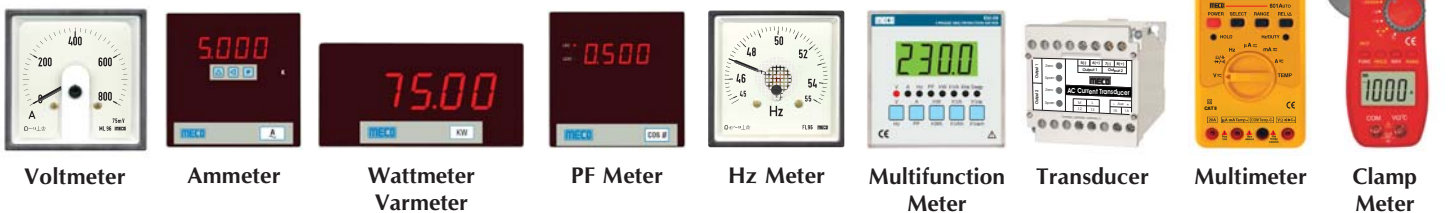



MODEL 90A Universal Calibrator gives a standard output for AC Voltage, DC Voltage, AC Current & DC Current. Keys or Knob help to adjust the magnitude of the output signals. Important features include wide range, high accuracy, good stabilization, easy operation and portability. The Calibrator is ideal for testing ammeters and voltmeters upto 0.2 accuracy class.

Applications

- Calibration of AC Volt, Amp, Frequency Meters
- Calibration of DC Volt, Amp Meters
- Calibration of Resistance Meters, Clamp Meters, Multimeters

Standard Accessories

- 1 x Key Adjuster
- 1 x Power Cord
- 1 x Pair of Output Leads
- 2 x Fuse (2A)
- 1 x Data Cable for PC Connectivity
- 1 x Operation Manual

Optional Accessories

- Standard Current Coil



Turns Ratio	50 / 1
Input Max.	20A
Current	1000A
Clamp Jaw	>28mm
DC Impedance	0.9Ω
DC Burden	20A / 1.3V
AC Burden	20A / 3V
Frequencies	DC to 60Hz
Accuracy	± 0.3% rdg

Technical Specifications

Voltage Control	Output Voltage Range : Basic Error :	200mV, 1V, 2V, 5V, 10V, 20V, 50V, 100V, 200V, 500V, 1000V DCV : ± (0.03 %RD + 0.02 %FS) ACV : ± (0.05 %RD + 0.03 %FS)
Current Control	Output Current Range : Basic Error :	100μA, 500μA, 2mA, 5mA, 20mA, 50mA, 200mA, 500mA, 2A, 5A, 20A DCI : ± (0.05 %RD + 0.02 %FS) ACI : ± (0.07 %RD + 0.03 %FS)
Frequency Control	Frequency Range : Frequency Error :	50Hz, 60Hz, 400Hz < 1 %
Resistance Control	Resistance Range : Basic Error :	10, 24, 50, 100, 240, 500 (Ω), 1, 2.4, 5, 10, 24 (kΩ), 10x1k, 24x1k, 50x1k, 100x1k, 240x1k, 500x1k, 1kx1k, 2.4kx1k, 5kx1k, 10kx1k, 24kx1k ± 0.2 % + 20mΩ

Note - RD : Reading, FS : Full Scale

General Specifications

<ul style="list-style-type: none"> ● Stability DC : < 0.01 %FS / 2 min, AC : < 0.03 %FS / 2 min ● Ripple : < 0.1 % ● Power Supply : 230 VAC, 50 (60) Hz ● Power Consumption : < 180 VA ● Operating Temperature : 5°C to 35°C ● Relative Humidity : ≤ 80 % 	<ul style="list-style-type: none"> ● Distortion : < 0.5 % ● Display : 5½ Digit LED Digital Display ● Step adjustment of Output Signal : 10 %FS, 1 %FS, 0.1 %FS, 0.05 %FS ● Dimensions : 147 x 480 x 480mm (approx.) ● Total Weight : 17 kgs (approx.)
-----------------------------------------------------------------------------------------------------------------------------------------------------------------------------------------------------------------------------------------------------------------------------------------------------------------------------------	-------------------------------------------------------------------------------------------------------------------------------------------------------------------------------------------------------------------------------------------------------------------------------------------------------------



90DQ

MODEL 90DQ Multifunctional calibrator can output standard AC voltage, DC voltage, AC current & DC current. Output actual value, percent and FS display at the same time. Calibrator may select FS (full scale) and relevant step in according with scale of UUT (unit under test). Keys or knobs adjust magnitude of the output signals. Wide range, high accuracy, good stabilization, easy operation and portable. The calibrator applies to test amperemeter and voltmeter upto 0.2 class.

Applications

- Calibration of AC Volt, Amp, Frequency Meters
- Calibration of DC Volt, Amp Meters
- Calibration of Resistance Meters, Clamp & Multi Meters

Standard Accessories

- 1 x Key Adjuster
- 1 x Power Cord
- 1 x Pair of Output Leads
- 1 x Pair of Output Leads (50A)
- 2 x Fuse (4A)
- 1 x Data Cable for PC Connectivity
- 1 x Operation Manual

Optional Accessories

- Standard Current Coil



Turns Ratio	100 / 1	100 / 1
Input Max.	5A	10A
Current	500A	1000A
Clamp Jaw	> 20mm	> 28mm
DC Impedance	0.7Ω	0.9Ω
DC Burden	5A / 3.5V	10A / 2.5V
AC Burden	5A / 6V	10A / 5V
Frequencies	DC to 60Hz	DC to 60Hz
Accuracy	±0.3% rdg	±0.3% rdg

Technical Specifications

Voltage Control	Output Voltage Range : Basic Error :	250mV, 1V, 2.5V, 5V, 10V, 25V, 50V, 100V, 250V, 500V, 1000V DCV : ± (0.02 %RD + 0.01 %FS) ACV : ± (0.05 %RD + 0.02 %FS)
Current Control	Output Current Range : Basic Error :	100μA, 500μA, 2.5mA, 10mA, 25mA, 100mA, 250mA, 1A, 2.5A, 10A, 50A DCI : ± (0.02 %RD + 0.01 %FS) ACI : ± (0.05 %RD + 0.02 %FS)
Frequency Control	Frequency Range : Frequency Error :	50Hz, 60Hz, 400Hz, 1kHz < 0.1 %
Resistance Control	Resistance Range : Basic Error :	10, 24, 50, 100, 240, 500 (Ω), 1, 2.4, 5, 10, 24 (kΩ), 10x1k, 24x1k, 50x1k, 100x1k, 240x1k, 500x1k, 1kx1k, 2.4kx1k, 5kx1k, 10kx1k, 24kx1k ± 0.2 % + 20mΩ

General Specifications

Note - RD : Reading, FS : Full Scale

- Stability DC : < 0.01 %FS / 3 min, AC : < 0.02 %FS / 3 min
- Ripple : < 0.2 %
- Power Supply : 230 VAC, 50 (60) Hz
- Power Consumption : < 250 VA
- Operating Temperature : 5°C to 35°C
- Relative Humidity : ≤ 80 %
- Distortion : < 0.5 %
- Display : 5½ Digit LED Digital Display
- Step adjustment of Output Signal : 100 %FS / N, 10 %FS / N, 1 %FS / N, 0.1 %FS / N (N = 4, 5, 6, 10 and 15)
- Dimensions : 190 x 480 x 545mm (approx.)
- Total Weight : 22.5 kgs (approx.)



MODEL 90P AC multifunctional calibrator can output standard AC voltage and AC current. It measures AC Voltage, AC current, power, phase angle, power factor and frequency (40Hz ~ 70Hz). Wide output range of current and voltage; High reliability and low wave distortion.

Applications

- Calibration of Power Meters, AC Volt, Amp, Watt, Var, Frequency, Powerfactor, Phase Angle and Energy Meters.
- Calibration of Voltage, Current, Active & Reactive Power, Frequency, Powerfactor, Phase angle and Energy Transducers.

Standard Accessories

- 1 x Key Adjuster
- 1 x Power Cord
- 1 x Pair of Output Leads
- 1 x Pair of Output Leads (50A / 100A)
- 2 x Fuse (4A)
- 1 x Data Cable for PC Connectivity
- 1 x Operation Manual

Optional Accessories

- Standard Current Coil



Turns Ratio	100 / 1	100 / 1
Input Max.	5A	10A
Current	500A	1000A
Clamp Jaw	> 20mm	> 28mm
DC Impedance	0.7Ω	0.9Ω
DC Burden	5A / 3.5V	10A / 2.5V
AC Burden	5A / 6V	10A / 5V
Frequencies	DC to 60Hz	DC to 60Hz
Accuracy	±0.3% rdg	±0.3% rdg

Technical Specifications

Voltage Control	Output Voltage Range :	1V, 2V, 5V, 10V, 20V, 50V, 75V, 150V, 300V, 600V, 1000V
	Min. Resolution :	0.02mV
	Basic Error :	AC V : ± (0.03 %RD + 0.02 %FS)
Current Control	Output Current Range :	10mA, 20mA, 50mA, 200mA, 1A, 2A, 5A, 10A, 25A, 50A, 100A
	Min. Resolution :	0.2μA
	Basic Error :	AC I : ± (0.03 %RD + 0.02 %FS)
Frequency Control	Frequency Range :	40Hz to 70Hz
	Frequency Error :	± 0.02 Hz
Phase Control	Phase Angle Range :	0 to 359.99°
	Phase Error :	± 0.05°

Note - RD : Reading, FS : Full Scale

General Specifications

<ul style="list-style-type: none"> ● Power Range : 0 to 100kW ● Power Basic Error : ± (0.07 %RD + 0.03 %FS) ● Stability V, I : < 0.01 %FS / 2 min, P : < 0.02 %FS / 2 min ● Distortion : < 0.5 % ● Power Factor Range : -1 to +1 ● Power Factor Basic Error : ± 0.001 (PF 0 to ±0.8); ±0.0005 (PF -0.8 to -1, +0.8 to +1) 	<ul style="list-style-type: none"> ● Power Supply : 230 VAC, 50 (60) Hz ● Power Consumption : < 300 VA ● Display : 5½ Digit VFD Digital Display ● Operating Temperature : 5°C to 35°C ● Relative Humidity : ≤ 80 % ● Dimensions : 192 x 480 x 540mm (approx.) ● Total Weight : 23 kgs (approx.)
------------------------------------------------------------------------------------------------------------------------------------------------------------------------------------------------------------------------------------------------------------------------------------------------------------------------------------------------------------------------------------------------	-------------------------------------------------------------------------------------------------------------------------------------------------------------------------------------------------------------------------------------------------------------------------------------------------------------------------------------------------------------------------

CE



333



Features

- 4-20mA (1KΩ Load, 24V Loop Supply) with 1μA Resolution
- 0-100.00mV, 0-1.0000V, 0-12.000V
- K, J, E & T Thermocouples (°C and °F)
- Frequency : 1-62500 Hz
- DC Current Basic Accuracy : 0.025%
- Easy Key Pad Number Operation
- Easy Step and Auto Ramp Functions
- 0-20mA & 0-24mA Selectable
- 0-100% Output (mA, mV, V)
- Beeper Warning when Output is Open (mA) or Short (mV, V)

Electrical Specifications (23°C ± 5°C, 5 minutes after power is on)

mA DC Current (1KΩ max. Load, 24V Loop Supply)		
Range	Resolution	Accuracy
4-20 mA, 0-20 mA, 0-24 mA	1 μA	± 0.025%rdg ± 3μA

Beeper Warning when Output is Open and specified Current Output > 1mA

mV, V DC Voltage (1 mA Supply Current)		
Range	Resolution	Accuracy
0-100.00 mV	10 μV	± 0.05%rdg ± 30 μV
0-1.0000 V	100 μV	± 0.05%rdg ± 300 μV
0-12.000 V	1 mV	± 0.05%rdg ± 3mV

Beeper Warning when Output is short and specified Voltage Output > 10mV

Frequency (1 KΩ Load Min.)		
Range	Resolution	Accuracy
1-125 Hz	1 Hz	± 0.04 Hz
126-62500 Hz	1 Hz	± 0.01% ± 0.04 Hz

K, J, E and T Type Thermocouples (1°C, 1°F Resolution, 1KΩ Load Min.)			
Range	Accuracy	Range	Accuracy
K : -200 to -100°C	± 2.0°C	K : -328 to -148°F	± 3.6°F
K : -100 to 0°C	± 1.1°C	K : -148 to 32°F	± 1.8°F
K : 0 to 1370°C	± 0.8°C	K : 32 to 2400°F	± 1.5°F
J : -100 to 0°C	± 0.9°C	J : -148 to 32°F	± 1.6°F
J : 0 to 760°C	± 0.7°C	J : 32 to 1400°F	± 1.2°F
E : -100 to 0°C	± 0.9°C	E : -148 to 32°F	± 1.6°F
E : 0 to 700°C	± 0.7°C	E : 32 to 1292°F	± 1.2°F
T : -200 to 0°C	± 1.0°C	T : -328 to 32°F	± 1.8°F
T : 0 to 400°C	± 0.8°C	T : 32 to 752°F	± 1.5°F

General Specifications

Battery Type	9V Eveready Type 216 or Equivalent & External Battery Pack (6 x 1.5V AA Batteries)
Display	4 and 5 Digits LCD Display with Annunciator
Operating Environment	0° to 50°C (32 to 122°F), RH < 85%
Storage Environment	-20°C to 60°C (-4 to 140°F), RH < 85%
Dimensions	88 x 168 x 38 mm (approx.)
Weight	330gms Including Battery (approx.)
Accessories	Carrying Case x 1, Users Manual x 1, K type Thermocouple Connector x 1, External Battery Pack Holder 1.5V AA Batteries x 6, 9V Battery (installed), Pair of Alligator Test Leads x 1

MECO®

SINCE 1962

Current Transformers (CT's)

- Clamp-On CT's
- Precision Split Core CT's
- PCB Mountable High Precision CT's



Reliable, Long-Lasting and Affordable Instruments ...since 1962 !

www.mecoinst.com

An ISO 9001-2008 Certified Company

MECO INSTRUMENTS PRIVATE LTD.

NAVI MUMBAI

CE



M1



S



FLEX-3000A

Model M1	
Transformer ratio (Arms)	100 A/1A
Rated burden	1W
Maximum load	2W
Overload (Arms)	120% continuous, 150% for 5 min/ h
Weight	100 gm approx.
Colours	Red, Yellow, Blue
Dimensions	97 x 46 x 27 mm.
Jaw opening	Cable Dia 15 mm max.
Accuracies	
for 50 Hz	± 2% of rdg. for 5A to 10A ± 1% of rdg. for 10A to 150A
for 2000Hz	± 1% of rdg. for 100A
for 50A	± 2% from 30Hz to 10000Hz
for phase	from 1° to 2.5°
Connections	Safety sockets for banana plugs ø 4mm

Flexible AC Current Probe - 3000A AC	
MECO FLEX - 3000A is designed for accurate measurement of AC, Pulsed DC or complex wave form of very low frequency upto 100kHz.	
It is very handy to pass through cables or bunches of conductor wires upto a diameter of 170mm (max.) The Clamp-On type Flex 3000 measures the current passing through the conductor. The output through 4mm banana pins can be connected to any Digital Multimeter in mV AC range to read the primary current upto 3000A AC.	
Model	FLEX 3000A
Range	3000A AC
Output	100mV / 1 KA AC
Accuracy	± 1%
Probe Length	600mm
Output Terminal	4mm Banana Pins

Ordering Information : Model, CT Ratio, Single / Triple Range, Colour

Model S	Transformer ratio (Arms) : 200/5A, 500/5A, 1000/5A (Single Range) 100, 500, 1000/5A (Triple Range)	Connections : Safety sockets for banana plugs ø 4mm
Overload (Arms)	: 120% continuous, 200% for 5 min/ h	
Weight	: 535 gm approx.	
Colours	: Red, Yellow, Blue	
Dimensions	: 217 x 109 x 40 mm.	
Jaw Opening	: Cable Dia 53 mm max.	
Bus bar	: 51 x 12mm	

Accuracy class	2	1	0.5
Rated burden	0.8W	0.4W	0.2W
Frequency range	30Hz to 5000 Hz	45 Hz to 1000Hz	50 Hz to 400 Hz

Limits of Errors for : The secondary burden is any value from 25% to 100% of the rated burden (with 1VA min.), 50Hz/60Hz and 20°C

Rated Current Shown Below as % Ipn									
% Ipn	5%	10%	20%	100%	120%	5%	20%	100%	120%
ACCURACY	Percentage ratio MAX. in ± % Ipn					Phase displacement MAX. in ± Minutes			
Class 0.5	1.5	1.5	0.75	0.5	0.5	90	45	30	30
Class 1	3.0	3.0	1.5	1	1	180	90	60	60
Class 2	4	4	3	2	2	No specified			
To obtain the error for an intermediate value of Ipn use linear interpolation.									

Note
Clamps with specifications other than above available subject to technical specifications.

Caution
The current probe secondary should never be open-circuited. Otherwise, lethal voltages will be developed and the probe will be damaged. Always complete the secondary connection firmly before clipping on the probe to the circuit. For disconnection, reverse the sequence. For power measurements, ensure the correct P1, P2 and S1, S2 polarities as indicated by the arrows on the Probe.



CCT50

CCT50 & CCT08 Clamp-On Current Transformer's are designed for fast and easy installation. These Clamp-On Current Transformers use Permalloy Magnetic Core or Silicon Amorphous Core, with characteristics of small size, high precision, good stability and strong anti-interference ability. These sensor's give a standard AC Current output which is suitable to conveniently measure on Single Phase / Three Phase Circuits with good stability and high anti-interference ability. It is ideal for power and energy measurement with high precision and small phase angle error in applications related to electric power, communication, monitoring and control. It can measure a variety of electric parameters without removing cables. The Standard length of Output Leads is 2 Meter. However Output and Leads Cable can be customized for bulk requirements.

Features

- Clamp-On Design, Fastening, Safe, Easy to Install, Portable.
- Wide Inner Window, Allowing Clamping of Big Cables or Bus-Bars.

Applications

- Current Measurement, Monitoring and Protection for Electrical Wiring and Equipment.
- Current and Power Measurement for Electric Motors, Lighting, Air Compressor, Heating and Ventilation System, Air-Condition Equipment and Automation-Control System.
- Current, Power and Energy Monitoring Device.
- Relay Protection Device.

Circuit Connection Diagram

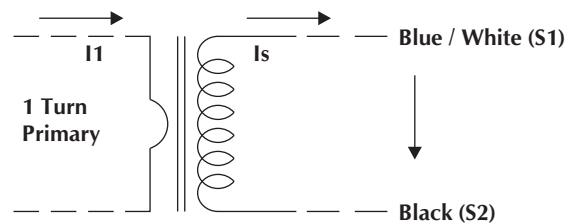

Electrical Specifications

Frequency	50 - 400Hz
Rated Input	As Below
Measuring Range	5% In - 130% In
Rated Output	0 - 5A AC (Standard) 0 -1A AC or 0-10V AC (Optional)
Ratio	± 0.1 %
Phase Angle	± 10min
Dielectric Strength	3.0KV / 1mA / 1min
Insulation Resistance	DC500V / 100MΩ min

Mechanical Specifications

Case	ABS / UL 94 - Vo
Bobbin	PBT
Core	Silicon Steel / Permalloy
Internal Structure	Screw
Construction	Screw
Operating Temp.	-25°C ~ +75°C
Operating Humidity	≤ 85 %
Output Connection	UL1015 22AWG Wire (Twisted Wire) 2m

Model	Rated Input (A AC)	Rated Output	Accuracy	Dimensions (mm) (ID - L - W - H)
CCT08	0 - 20A	5A AC (Standard) 1A AC or 10V AC (Optional)	1.0	8.0 - 135.0 - 42.0 - 20.0
CCT50	0 - 100A			50.0 - 215.0 - 104.0 - 27.0
	0 - 500A			
	0 - 1000A			

Ordering Information : Model, Rated Input (A AC) & Rated Output



FCT Series

MECO FCT is a Flexible Current Transformer based on the Rogowski principle. It is suitable to conveniently measure Single / Three Phase AC and Pulsed DC Currents. After approximate signal conditioning, it can be used with Digital Multimeters, Recorders and other suitable equipment to measure current from very low frequencies up to 1MHz.

The probe comprises of a flexible air-cored sensor which can be opened and installed around a primary conductor without interrupting the circuit. The flexible and lightweight measuring head allows quick and easy installation in hard to reach areas and over large conductors. Inner Diameter / Window Size and leads can be customized.

Specification

Typical Voltage Output VoRMS (Sinusoidal Current)	$(2.183 \times 10^{-6}) \times I_{RMS} \times \text{Frequency}$	Bandwidth	5Hz ~ 1MHz
VoRMS (at 3000ARMS, 50 Hz)	100mV AC	Accuracy	± 0.2% (Most accurate position, 25°C)
Rated Current (RMS)	3000A	Phase Shift	90 ± 0.2 degrees
Inner Diameter / Window Size	127mm (5")	Temperature Sensitivity	0.08% per °C
Coil Diameter	9 mm	Position Sensitivity	± 0.5%
Internal Resistance per Probe	120Ω	Working Voltage	1000V AC RMS
Operating Temperature Range	-10°C to + 60°C	Colour	Red, Yellow, Blue and Black
Storage Temperature Range	-20°C to + 70°C		



CCT Series

MECO CCT Series of Clamp-On Current Transformer's are designed for fast and easy installation. Clamp-On Current Transformer uses Permalloy Magnetic Core or Silicon Amorphous Core, with characteristics of small size, high precision, good stability and strong anti-interference ability. These sensor's give a standard AC Current output which is suitable to conveniently measure on Single Phase / Three Phase Circuits with good stability and high anti-interference ability. It is ideal for power and energy measurement with high precision and small phase angle error in applications related to electric power, communication, monitoring and control. It can measure a variety of electric parameters without removing cables. The Standard length of Output Leads is 2 Meter. However Output and Leads Cable can be customized.

Specification

Model	Window size/ ID (mm)	Primary Current (A AC)	Secondary Output (A AC)	Accuracy
CCT602	60	0 ~ 2000A	5A	1.0



MECO Split Core Current Sensor's are designed for fast and easy installation. Split Core Current Sensor's are ideal for installation on existing electrical wiring by snapping around the conductor. This method permits safe, easy and portable current measurement. These sensors are small in size and have a secure locking hinge. The Sensor's have a high secondary to primary turn ratio.

Specification

- Rated Output : 0.333VAC
- Current Ratio : 3000:1
- Insulation Voltage : 600VAC
- Maximum Primary Voltage : 5000VAC (Insulated Conductor)
- Operating Temperature : - 15°C to 60°C
- Frequency Range : 50 - 400Hz
- Leads : 1 Meter, Twisted Pair, 22AWG
- UL, ETL and CE Recognized
- RoHS Compliant
- Output and Leads (can be customized)

Models	Window Size/ ID (mm)	Ratio	Rated Amps Input (AC)	Output (AC)	Accuracy
MH-SCT-T06	6	1000 : 1	1, 5, 10, 15, 20	0.333V AC	0.5, 1.0
MH-SCT-T10	10	3000 : 1	5, 15, 30, 50, 75, 80		0.5, 1.0
MH-SCT-T16	16	3000 : 1	50, 70, 100, 120		0.5, 1.0
MH-SCT-T24	24	3000 : 1	100, 150, 200, 300		0.5, 1.0
MH-SCT-T36	36	3000 : 1	300, 400, 500, 600		0.5, 1.0



MECO Split Core Current Sensor's are designed for fast and easy installation. Split Core Current Sensor's are ideal for installation on existing electrical wiring by snapping around the conductor. This method permits safe, easy and portable current measurement. These sensors are small in size and have a secure locking hinge. The Sensor's have a high secondary to primary turn ratio. These sensor's give a standard 5A AC or 1A AC output (any one only) which is suitable to conveniently measure on Single Phase / Three Phase Circuits with good stability and high anti-interference ability. It is ideal for power and energy measurement with high precision and small phase angle error in applications related to electric power, communication, monitoring and control. It can measure a variety of electric parameters without removing cables.

Specification

- Rated Current : 100A to 500AAC
- Rated Output : 1A or 5AAC at Rated Current (Any one only)
- Accuracy : ± 1% at 2VA
- Insulation Voltage : 600VAC
- Maximum Primary Voltage : 5000VAC (Insulated Conductor)
- Phase Angle : < 2 Degrees at 50% of Rated Current
- Frequency Range : 50 - 400Hz
- Operating Temperature :-15°C to 60°C
- Leads : 1 Meter, Cable
- CE Recognized
- RoHS Compliant
- Output and Leads (can be customized)

Models	Window Size/ ID (mm)	Rated Amps Input (AC)	Output (AC)	Accuracy
MH-SCT-T24	24mm	100, 150, 200, 300	5A or 1A AC (Any one only)	0.5, 1.0
MH-SCT-T36	36mm	100, 200, 300, 500		0.5, 1.0



CC Series



CB Series

Features

- Low Cost
- Low Profile for PCB Mounting
- High Accuracy
- Wide Linear Range
- Low Phase Shift Error
- Flame Retardant
- Nano Crystalline / Permalloy Core

Specifications

- Accuracy : Class : 0.1
- Dielectric Strength : 2.5KV at 50Hz for 1 min.
- Dielectric Resistance : 100M Ohms @ 500V DC
- Working Frequency : 50 ~ 400Hz

Application

- Electronic Energy Meter
- Power Transducer
- Precision Power Meter
- Power and Energy Monitoring Devices
- Over Current Protection Circuit of Motor and

- Ambient Temperature : - 25°C ~ + 55°C
- RoHS Compliance
- CE Approved
- Customer Specifications are Available

Parameters

Series	Model	DCR Max. (Ohm)	Rated Primary (A)	Rated Secondary (mA)	Number of Turns (T)	Rated Secondary Burden	Accuracy (%)	Phase Shift/ Angle Max.	Linear Range
CC Series	WCT102/CC	60	5	5	1000	10	0.1	≤ 25' / 0.5°	4
	WCT202/CC	200	5	2.5	2000	50	0.1	≤ 25' / 0.5°	5
	WCT252/CC	320	5	2	2500	50	0.1	≤ 25' / 0.5°	5
CB Series	WCT202/CB	90	5	2.5	2000	50	0.1	≤ 15' / 0.25°	10
	WCT252/CB	120	5	2	2500	100	0.1	≤ 10' / 0.16°	10

Dimensions

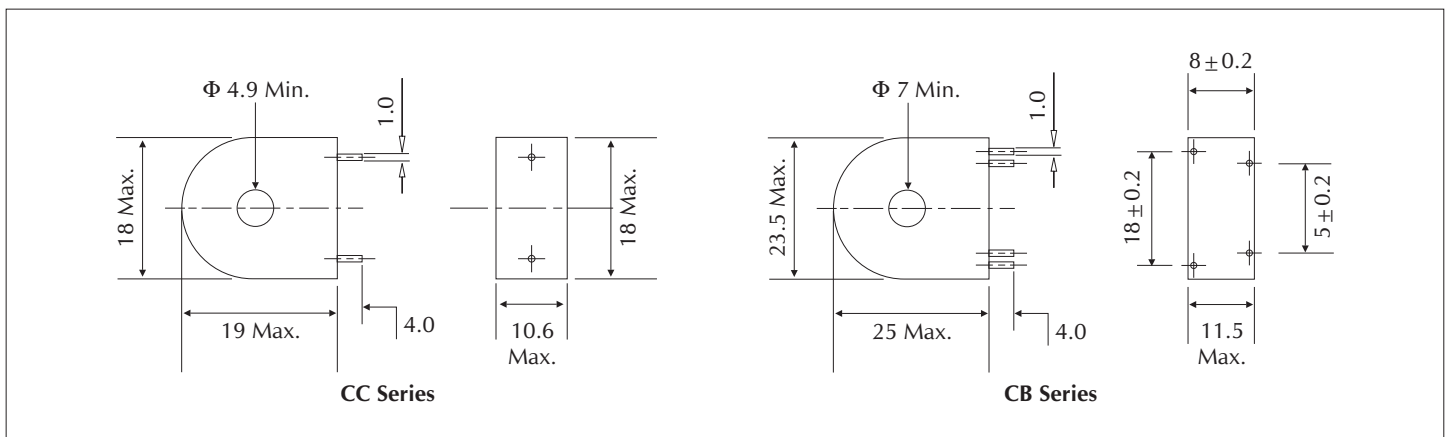



Welcome to MECO - Mahape



Sales & Marketing Department



Product Display Gallery



Incoming QC



Stores & Material Handling



Meter Assembly Line



Conveyor Belt Production Line



World Class Calibrating Equipment



Burn-In at 55°C to Ensure Stability



Environmental Chamber To Simulate
-20°C to 100°C (Rh upto 100%)



In-House Tool Room Facility



Final Packaging for Safe & Secure
Transportation



Training



Seminar



MECO Awards



ISO 9001:2008 CERTIFICATE

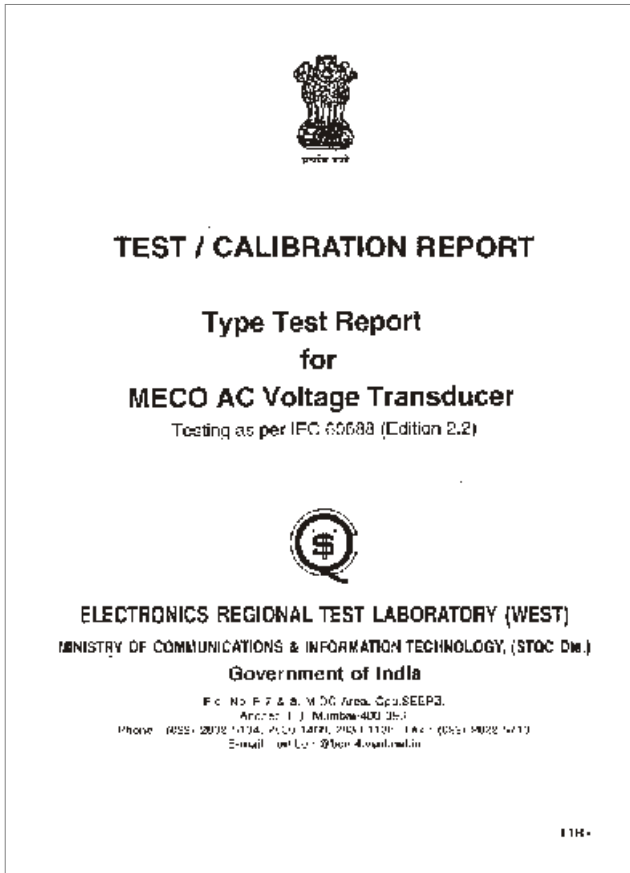

STQC TYPE TEST REPORT

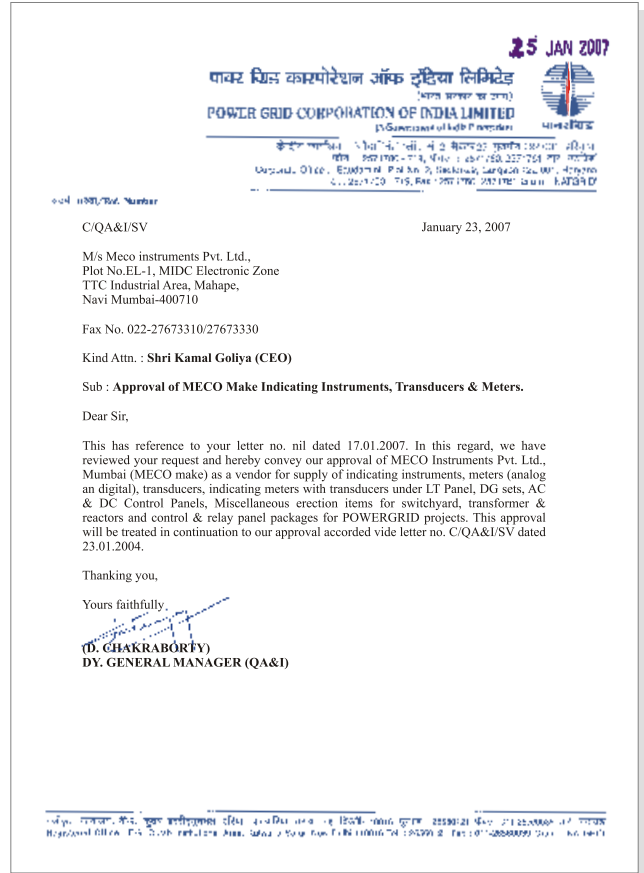

PGCIL APPROVAL

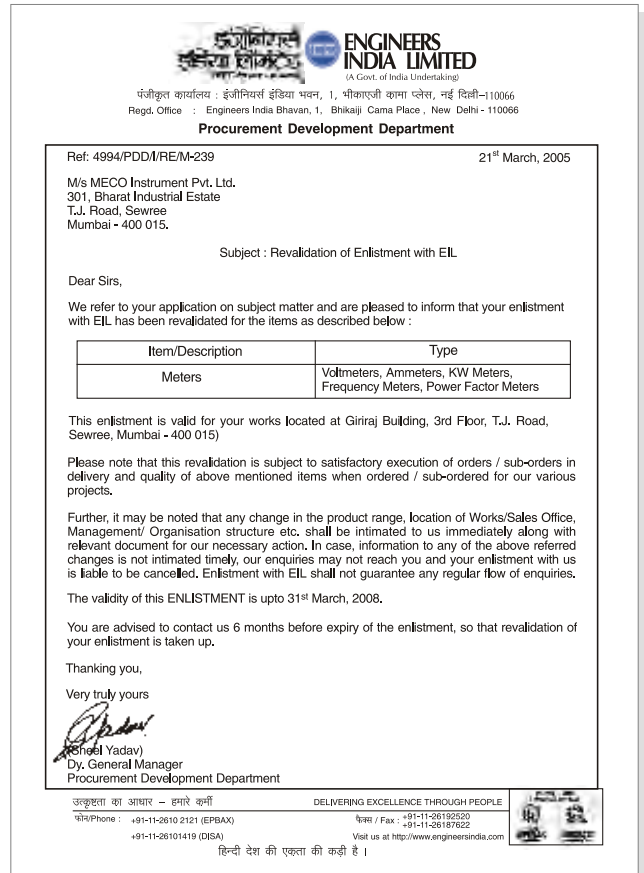

EIL APPROVAL



ISO 9001-2008 Certified Company

MECO INSTRUMENTS PRIVATE LTD.

EL-1, MIDC Electronic Zone TTC Industrial Area, Mahape, Navi Mumbai - 400710 (INDIA)
Tel. : +91-22-27673311-16 (Sales), 27673300 (Board) Fax : +91-22-27673310 / 27673330

Email : sales@mecoinst.com Web : www.mecoinst.com